



*2015-2016 Machining and Manufacturing Technology*

# *PROGRAM*

# *REVIEW*

Self Study Report

Prepared by Robert Mabry

# **MACHINING AND MANUFACTURING TECHNOLOGY**

## **EXECUTIVE SUMMARY**

### **TABLE OF CONTENTS**

- I. PROGRAM DEFINITION, HISTORY AND MISSION – Page 1**
- II. STATUS SUMMARY - FINAL PLAN OF ACTION – Page 1**
- III. PROGRAM REVIEW COMPREHENSIVE SELF STUDY – Page 3**
  - 1. Progress Made Toward Past Program/Departmental Goals
  - 2. Analysis of Resource Use and Program Implementation
  - 3. Program SLOS/Assessment
  - 4. Trend Analyses/Outlook
  - 5. Long-Term Program Goals and Action Plans (Aligned with the College Educational Master Plan)
- IV. STUDENT DATA SUMMARY – Page 15**
- V. COURSE REVIEW – Page 19**
  - 1. Course Review Verification Sheet
  - 2. Review Of Prerequisites, Corequisites, and Advisories
  - 3. Degree and Certificate Requirements
- VI. ADVISORY COMMITTEE – Page 25**
- VII. VALIDATION – Page 27**
  - 1. Validation Team Member List
  - 2. Plan Of Action – Pre-Validation
  - 3. Executive Summary
  - 4. Plan Of Action – Post Validation
  - 5. Signature Page
- VIII. SUPPORTING DOCUMENTATION – Page 35**
  - 1. Appendix A – 2014 MT Student Surveys
  - 2. Appendix B - IRP Program Review Data Set
  - 3. Appendix C - MT Student Learning Outcomes
  - 4. Appendix D - Outside Resources
  - 5. Appendix E - Employment Outcomes and Projections
  - 6. Appendix F - May 20, 2014 Manufacturing Education Summit Presentation
  - 7. Appendix G - Course Outlines of Record (CORs)

## I. PROGRAM DEFINITION, HISTORY AND MISSION

The Machining and Manufacturing Technology program (MT) prepares students for entry-level positions in manufacturing and develops the skills of concurrent manufacturing employees in Santa Barbara and San Luis Obispo counties.

The program is one of three machining and manufacturing programs within the South Central region. Ventura College and College of the Canyons offer the other programs. The distances from AHC to Ventura College and College of the Canyons are 96 and 137 miles respectively.

In January 2015, there were 19,300 manufacturing employees in Santa Barbara and San Luis Obispo counties. The demand for skilled workers in manufacturing exceeds the supply, creating a continuing need for this program.

The program was maintained by part time faculty for 10 years following the 1999 retirement of Dick Dixon. Program review was last conducted by Dean Ray Hobson in 2002-2003. All of the MT Course Outlines of Record (CORs) were created in the 1980s and the program had fallen way behind in its effort to keep current with the technology used in modern manufacturing.

With the help of its industry partners, the program rebounded when full time faculty was hired in 2009. The advisory committee was reconstructed and expanded. It made important recommendations for the development of new curriculum, assisted in recruiting students and stepped forward to teach many of the new classes.

With the addition of full time faculty, the MT program grew to become the 3<sup>rd</sup> largest in the Industrial Technology department with 49 FTES by 2013-2014.

## II. STATUS SUMMARY - FINAL PLAN OF ACTION

The 2002-2003 program review included five recommendations that were acted upon in subsequent years.

1. The program needs to have a full time faculty member assigned to expand course offerings, and develop curriculum	Full time faculty was hired in August 2009. Course expansion and curriculum currency was accomplished by the end of 2013-2014.
---	--

<p>2. The department needs to develop a marketing plan designed to increase student participation rates and support expanding into daytime offerings</p>	<p>Outreach targeting manufacturers on the Central Coast highlighting MT course offerings began in 2009 and has continued prior to every semester since. These communications supplement the AHC schedules and promotional material produced the office of Public Affairs.</p>
<p>3. The advisory committee needs to be reconstituted and scheduled for annual meetings</p>	<p>An advisory committee comprised of industry professionals has emerged since 2009. Committee members have been very active with curriculum development, student recruitment, equipment recommendations, factory tours, internships and symposiums on advanced manufacturing.</p>
<p>4. Research needs to be conducted to determine what makes the program exceed state negotiated levels of performance on some Core Indicators, and not meet or exceed those levels on other Core Indicators</p>	<p>The advisory committee coordinated a fund-raising campaign during 2011-2012 that raised \$130,000 to partially fund the full time faculty position through 2014-2015.</p> <p>Program performance in Core indicators remains weak with non-traditional students. Solutions to these issues need to be researched and addressed on a society-wide basis.</p>
<p>5. All course descriptions need to be rewritten to enhance the descriptions of expected student outcomes and evaluation criteria.</p>	<p>In 2009, course outlines in the program were more than 20 years old. The tools, processes and procedure described in those course outlines were no longer in use by manufacturers. As of 2014-2015, all the courses have been modified or replaced with courses that address</p>

	current processes in advanced manufacturing.
--	--

### III. PROGRAM REVIEW COMPREHENSIVE SELF STUDY

#### 1. Progress Made Toward Past Program/Departmental Goals

In 2006, Dean Hobson envisioned that “Allan Hancock College (AHC) is well positioned to transition its machining program to provide *advanced manufacturing* technology education and training within the geographic region encompassing Ventura, Santa Barbara and southern San Luis Obispo counties.”

To do this, full time faculty was needed. Dean Anne Cremarosa hired faculty in August 2009 and tasked them with making that lofty transition in just two years. This was a grant-funded position and there was little time to spare in moving the program forward.

Faculty organized an open house in the MT machine lab in September 2009. Several hundred invitations were sent to manufacturers in Santa Barbara and San Luis Obispo counties and more than 60 people attended the event.

10 professionals from that open house met with MT faculty and Dean Cremarosa shortly thereafter, and a new MT advisory committee was established.

The new partners were full of ideas for how to rebuild the MT program and eager to share their thoughts with AHC faculty.

The first order of business was to create new curriculum. Experimental courses were created in CNC machining, Lean and Green Manufacturing, computer-aided-design and manufacturing (CAD/CAM) and 3D design.

Also in this period, a lot of energy went into student recruitment. The first wave of new MT students were mainly concurrent employees of local manufacturers seeking to improve their skills. FTES in the program grew from 3.99 in the Fall of 2008 to 17.45 in the Fall of 2011 with hiring the full time faculty.

Employers assisted in recruitment by offering incentives for their employees to take classes and invited MT faculty to make recruiting visits to speak with their staff right inside the factory.

The program's return to viability nearly ended after its initial temporary term. The most severe economic downturn since the Great Depression brought faculty hiring to a halt. A permanent tenure-track MT position was posted in April 2011 then withdrawn when a campus-wide hiring freeze went into effect.

Dean Cremarosa extended the term of the temporary MT position for an additional year through 2011-2012. But there were no expectations that the economic situation would improve by then or that the school would return to normal hiring. Instead, AHC offered financial inducements for faculty to retire in order to reduce payroll even more.

MT faculty met with their closest advisors immediately following that 2010-2011 school year. The message faculty took to the partners was that the program would go away after 2011-2012 because there was no likelihood the college would be hiring faculty in the foreseeable future.

One of the advisors indicated they would provide financial support for the program and wondered out loud if others would also do so. A solid core of advisors decided to go out to others for an answer to that question.

They first met with Dr. Jose Ortiz and Luis Sanchez. The manufacturers proposed raising funds in exchange for a promise that the college would hire full time faculty with the money. The administrators agreed to the proposal if the committee would raise half of the funds needed to fill the position through the 2014-2015 school year.

Four companies in Santa Barbara County subsequently signed Memorandums of Understanding pledging to provide the college with a total of \$120,000 to sustain the program over that three year period.

Could this be viewed as a model for funding community college CTE programs like MT? The donors did not look at these contributions as charity. As they said, it was a corporate investment for which they expected a return. A modern CTE program has real value with our industrial partners.

With a full time position secured, faculty turned to raising funds to obtain-state-of-the-art industrial equipment. In collaboration with AHC's Grants Office, faculty wrote an application for an Industry Drive Regional Collaborative (IDRC) grant from the California Community College Chancellor's Office (CCCCO).

The funding was provided by the CCCCCO and AHC established the Central Coast Manufacturing Initiative (CCMI) as the platform administering the grant.

The grant funded state-of-the-art MT lab equipment valued at more than \$200,000. The machine tech lab today showcases this computer-numerical-controlled (CNC) equipment in the new Industrial Technology building, made possible by the support of the community through the 2006 Measure I Bond issue.

In addition to the machine lab, two new labs for computer-aided-drafting (CAD) were included in the new building. AHC is increasingly seen as the regional center for manufacturing technician training. Employers and employees are turning to AHC for job training and workers with the skills to succeed in advanced manufacturing.

The Central Coast Manufacturing Initiative greatly expanded the reach and influence of the MT program at AHC. The final report for this grant was written by faculty in January 2015. It measured the outcomes of the eight objectives faculty proposed in the 2012 grant application. The proposed objectives are in italics followed by the accomplishments achieved by the CCMI over the past three years.

*Objective 1: The Central Coast Manufacturing Initiative (CCMI), to be housed at Allan Hancock College, will support a regional infrastructure for meeting the technology education and training needs of approximately 175 companies in the manufacturing industry in Santa Barbara and San Luis Obispo Counties.*

The AHC Board of Trustees awarded a contract in July 2013 for \$190,199.63 to Haas Factory Outlet – Anaheim, a Division of Machining Time Savers, Inc. for computer-numerical-controlled (CNC) equipment that elevated the school's machine technology lab to a complete training center for advanced manufacturing.

The CCMI initiated a series of annual workshops in December 2013 with members of high school robotics teams in Santa Barbara County to fabricate robot components for regional, state and national competition.

Forty two employers responded to a CCMI survey in May 2014 outlining the knowledge, skills and abilities they seek when hiring new staff.

Mitsubishi Materials U.S.A. Corporation contributed \$5,859.50 in tools and materials to the Machining and Manufacturing Technology program at AHC in November 2014.

The Employer Advisory Council of the Santa Maria Valley contributed \$2,000 in December 2014 for computers in the new Industrial Technology computer lab to promote computer-aided-design (CAD) training in the region.

*Objective 2: The CCMI collaborative will provide direct services to enable new and incumbent workers to increase their competencies, identify career pathways, and become more competitive within the regional manufacturing industry.*

The CCMI sponsored 70 students from 4 local high schools and 10 students from AHC in a tour of Haas Automation in Oxnard in April 2013. Manufacturing engineers from Melfred-Borzall, Helical Products, Zodiac Aerospace, and Lockheed-Martin accompanied the students as mentors and tour guides.

The CCMI collaborated with the Center for Applied Competitive Technologies (CACT) at College of the Canyons to provide a series of contract education classes beginning in October 2013 at Zodiac Aerospace to provide incumbent workers with technical manufacturing skills.

President Obama proclaimed October 3, 2014 as National Manufacturing Day. The CCMI hosted 105 students from six high schools throughout the AHC district in visits to ten industrial enterprises in northern Santa Barbara County. The activity culminated in a tour of the new Industrial Technology building at AHC.

The Gene Haas Foundation contributed \$5,000 to support the new SkillsUSA chapter at AHC in December 2014. Students in SkillsUSA will learn soft skills and hone their technical abilities in regional, state and national competition.

*Objective 3: In response to industry demand, deliver cost-effective performance-oriented services that contribute to regional economic growth and competitiveness.*

The CCMI conducted Kaizen continuous improvement events at Helical Products in Santa Maria in April 2013 and at Allan Hancock College in April 2014 that were facilitated by Dr. Eric Olsen of Cal Poly San Luis Obispo and Leroy McChesney of Helical Products.

*Objective 4: a) Provide direct services that result in employees gaining relevant skills and increasing their competencies; and b) Ensure that employers have direct access to a pipeline of highly skilled trainees.*

The CCMI created four credit courses in August 2013 based on curriculum from the Manufacturing Skill Standards Council (MSSC) that will enable students to acquire portable, national, stackable and latticed credentials in the following industry-wide



technical competencies: Safety, Measurement, Manufacturing Processes and Maintenance Awareness.

The CCMI collaborated with Melfred-Borzall to provide summer internships in June 2014 for students in the Industrial Technology department at AHC.

*Objective 5: Develop a skilled, "just in time" workforce for the regional manufacturing industry.*

Concurrent with the term of the CCMI, AHC awarded seven AS degrees and 8 certificates in Machining and Manufacturing Technology. These were the first degrees and certificates awarded by the school in many years.

The Gene Haas Foundation contributed \$15,000 to the Machining and Manufacturing Technology scholarship fund in January 2015. The scholarships are to be given to students who are currently enrolled or who will be enrolled in a machining-based training program at the college level.

*Objective 6: Under the auspices of CCMI, enhance AHC's machining and engineering programs' network to ensure access to technical assistance in rural and urban communities throughout the state.*

July 2013 - Participated in the 11th annual Summer Teacher Conference at Cal Poly San Luis Obispo sponsored by the California Industrial & Technology Education Association (CITEA) and the Manufacturing Technology Teachers Association (MTTA). The conference provided an opportunity to explore new technologies and network with high school and community college CTE instructors.

Concurrent with the term of the CCMI, the Project Director attended South Central Regional Consortium (SCRC) and California Community College Association of Occupational Educators (CCCAOE) meetings and conferences.

The CCMI Project Director earned a certificate from the Leadership Academy at the California Community College Association of Occupational Educators (CCCAOE) Fall 2013 conference.

In October 2014, a local manufacturer recommended that members of the Refrigerating Engineers & Technicians Association (RETA) meet with AHC's manufacturing program to discuss developing a refrigeration operator training program. The twenty cooling facilities in the Santa Maria Valley that process local fruits and vegetables

have no access to refrigeration technician training and intend to partner AHC to meet their needs.

*Objective 7: Develop an outreach and marketing plan tailored to California's remote community colleges to ensure access to technical assistance in AHC's areas of expertise that can improve their economic development capability.*

The CCMI worked with AHC's office of Public Affairs to develop a color brochure promoting the Manufacturing Skill Standards Council (MSSC) curriculum and credentials.

*Objective 8: In partnership with the Workforce Resource Center and Economic Development Commission, AHC provides a forum for economic development stakeholders to collaborate on short-term and long-term goals that promote growth in the region.*

The CCMI hosted a Manufacturing Education Summit in May 2014 attended by more than 100 industrial and educational professionals representing 20 local companies, the Workforce Resource Center and several other social service agencies, high school and college administrators, and career counselors. The Summit was emceed by Dave Cross, director of the Santa Maria Economic Development Commission. Dr. Jose Macedo, Professor and Chair of the Industrial and Manufacturing Engineering Department at Cal Poly was the keynote speaker and discussed the current state of manufacturing and the future of this vital sector of our economy. Small group discussions were then led by Tom Fargher of Zodiac Aerospace, Scott Barton of Gavial Engineering, Rodney Babcock of Next Intent, Leroy McChesney and Alex Ek of Helical Products and Cynthia Holm of NuSil Technology).

We have learned that it is possible to find support for CTE programs so long as faculty is willing to listen and learn from the community it serves.

More than \$500,000 in outside resources have come to the MT program since 2011. Faculty believes that IDRC grant funds were provided in large part because of the pledges from our industrial partners to underwrite the MT faculty position.

Date	Source	Resource Description	Value
8/25/2011	Machining Time Savers, Haas Factory	1997 Haas VF-3 CNC Milling Machine Repair	6,877.50

Outlet			
12/13/2011	Melfred Borzall, Inc.	1997 Haas VF-3 CNC Milling Machine	30,000.00
2/23/2012	Karl Storz Imaging	MT Memorandum of Understanding	30,000.00
3/28/2012	Atlas Copco Mafi-Trench	780 pounds of aluminum	468.00
3/29/2012	Helical Products Company	MT Memorandum of Understanding	30,000.00
4/3/2012	Santa Maria Employer Advisory Council	Donation to purchase SolidWorks software	3,000.00
4/16/2012	Melfred Borzall, Inc.	MT Memorandum of Understanding	30,000.00
5/15/2012	Blaine Johnson Foundation	MT Memorandum of Understanding	30,000.00
1/8/2013	CCCCO	IDRC Grant - Year 1	277,468.00
7/22/2013	CCCCO	IDRC Grant - Year 2	36,144.00
7/30/2013	Zodiac Aerospace	MT Program Donation	5,000.00
9/18/2013	Zodiac Aerospace	MT Program Donation	5,000.00
10/10/2013	Zodiac Aerospace	Contract Education - Blueprint Reading	3,000.00
10/31/2013	Zodiac Aerospace	Contract Education - 3 axis CNC programming	5,060.00
12/6/2013	Atlas Copco Mafi-Trench	New Windows for Haas VF-3	1,370.00

12/13/2013	Zodiac Aerospace	Contract Education - 5 axis CNC programming	5,190.00
3/5/2014	Machining Time Savers, Haas Factory Outlet	(3) Haas Simulators and (1) Haas HA5C Indexer	12,080.00
9/3/2014	Santa Maria Employer Advisory Council	Donation for CAD lab computers	2,000.00
12/20/2014	Gene Haas Foundation	SkillsUSA Donation	5,000.00
1/20/2015	Mitsubishi Materials USA	Cutting Tools	5,859.50
1/28/2015	Zodiac Aerospace	Contract Education - Blueprint Reading	3,000.00
2/6/2015	Gene Haas Foundation	Scholarships Donation	15,000.00
		<b>TOTAL</b>	<b>\$541,517</b>

## 2. Analysis of Resource Use and Program Implementation

MT program transformation since 2009 would not have been possible without a full time faculty champion. It was sustained by part-time faculty for 10 years without an advisory committee, without new curriculum and without leadership.

The incumbent full time faculty will be retiring before the next six year program review. It is essential that full time faculty be hired to fill the position. When the college failed to fill vacant faculty positions in Electronics and Architecture these programs suffered. When the college deferred hiring faculty to replace retirees in Auto Tech and Welding, the programs, the Industrial Technology department and Allan Hancock College were adversely affected.

The time will come soon to identify the next full time faculty of the Machining and Manufacturing program. The only outcome of this conversation that would be in the interest of our students and our industrial partners would be a seamless transition to the next champion. The program is housed in the new Industrial Technology building, it features state-of-the art technology, has excellent relationships with the community and meets a great need in the region. This can only be sustained with a full time champion.

It should be mentioned that the program will need to respond to unforeseen changes in technology over the next six years and that will likely require the purchase of additional equipment. Existing equipment will likely need maintenance and repairs. Finally the program intends to expand into new technologies such as rapid-prototyping. A projection of these projected expenses is located in the supporting documentation.

Related to this is the need for additional support from Business Services. Programs in Industrial Technology consume more material and supplies than many other departments on campus. This leads to a higher number of purchase orders emanating from Industrial Technology and adequate support for these purchases is needed.

### **3. Program SLOs/Assessment**

Machining and Manufacturing Technology is an occupational program designed to prepare students for a variety of entry-level positions in a manufacturing environment. These positions may include manual machine operator, computer numerical control operator, computer aided drafting and manufacturing (CAD/CAM) designer, manufacturing generalist or programmer.

Classes are designed for first-time college students, re-entry students, and current industry employees requiring skill enhancement or upgrade training. Learned skills may include the ability to operate conventional and computer numerical controlled (CNC) machinery, program CNC machinery, operate various CAD/CAM systems and interpret blueprints. A degree or certificate in Machining and Manufacturing Technology is structured to encourage transfer to a comparable program at a four-year college or university.

Program Learning Outcomes: The graduate of the program in Machining and Manufacturing Technology will:

1. understand the importance of attendance and punctuality
2. have experience working in collaboration with others

3. possess essential academic skills in reading, writing, math, using and locating information and basic computer competency
4. communicate effectively and interpret key instructions
5. understand the basics of safety, quality assurance and continuous improvement, or lean manufacturing
6. function effectively in a manufacturing environment containing a variety of production, welding, machining and metal-forming or Computer Numerical Controlled (CNC) equipment
7. possess a variety of basic and high-tech skills consistent with modern manufacturing processes

#### **4. Trend Analyses/Outlook**

Conventional wisdom holds that the United States has become a post-industrial society and very little manufacturing takes place within its borders. To be successful and attract students, the MT program needs to help people see the truth – that manufacturing is thriving and a career in this field is both intellectually challenging and financially rewarding.

Modern manufacturing is comprised of additive and subtractive manufacturing. The program has begun experimenting with additive manufacturing with the acquisition of 3D printers and will need to place more emphasis on this emerging technology in the immediate future.

To that end, AHC hosted a manufacturing summit on May 20, 2014 where more than 100 educators, manufacturing professionals and other social service professionals heard a presentation by Dr. Jose Macedo, Professor and Chair of the Industrial and Manufacturing Engineering program at California Polytechnic State University San Luis Obispo. Dr. Macedo presented on the past, present and future of manufacturing in the United States.

Dr. Macedo's data showed the United States and China as nearly neck and neck in the race to lead manufacturing in the world today. Each country produces approximately 20% of the world's manufactured goods. (see the Supporting Documents).

Following Dr. Macedo's keynote address, attendees engaged in group discussions led by the manufacturing professionals who informed the educators about their urgent need

for qualified employees. The professional outlined the knowledge, skills and abilities most valued in entry level employees.

The MT program has deep roots within regional manufacturing. The program's industrial partners employ Allan Hancock College students in these manufacturing operations:

**Buellton**

Aero Industries  
Excelta Corp.  
G P Machining  
M3 Precision LLC  
Tilton Engineering

**Goleta**

CNC Machining Inc.  
Karl Storz Imaging  
N C Burnet Machining

**Grover Beach**

California Fine Wire Company

**Nipomo**

Malcolm DeMille, Inc.

**Paso Robles**

Specialty Silicone Fabricators

**San Luis Obispo**

Mainland Machine  
Next Intent Co.  
Top Precision LLC

**Santa Maria**

Alan Johnson Performance Engineering  
Aluma-Tech Inc  
Arrow Screw Products  
Artcraft Painting  
Atlas Copco Mafi-Trench  
Central Plastics & Mfg  
Hardy Diagnostics  
Helical Products Co Inc  
Hendrix Machine & Tool  
Kirby Morgan Dive Systems  
Melfred Borzall

Nickson's Machine Shop Inc  
Prince Lionheart  
Ray Nanini Manufacturing  
Santa Maria Tool Inc  
Simms Machinery International  
Wasco  
Zodiac Aerospace

**5. Long-Term Program Goals and Action Plans (Aligned With the College Educational Master Plan)**

A long term goal is to increase the visibility of manufacturing operations and opportunities on the Central Coast and the career pathways available to students toward this field.

Students, parents and counselors remain largely unaware of the career opportunities in advanced manufacturing and the quality of the Machining and Manufacturing program.

Welding students are introduced to MT through the Survey of Machining class that is required for its degrees and certificates.

The MT program organizes field trips for high school students to visit the Haas Automation factory in Oxnard and participate in National Manufacturing Day by sponsoring factory tours of area manufacturers.

The MT program would like to continue hosting annual Manufacturing Education Summits to discuss the opportunities a manufacturing career holds for the next generation.

More promotional opportunities like this will be needed to increase the visibility of manufacturing opportunities and the MT program. This will include expanding opportunities to showcase the new Industrial Technology building and its modern machine lab in particular. These tours should become a mainstay of all visits to the campus by high school students, faculty counselors and administrators.



#### IV. STUDENT DATA SUMMARY

32 students responded to the survey in July 2014.

**Part I of the Student Survey: Please indicate how satisfied you are, in general, with the following aspects of the Machining and Manufacturing Program.**

**State at least three positive factors about the discipline/program identified by students. Include the number (or percentage) of students responding and any implications for planning.**

81.3% of the respondents selected 1 or 2 on a scale of 5 with the “Quality of instruction within the program”. This is a reflection of the great work by the faculty in the program.

75.1% of the respondents selected 1 or 2 on a scale of 5 with the “The way this program meets your educational goals”. Students in this program seek 21<sup>st</sup> century job skills.

78.2% of the respondents selected 1 or 2 on a scale of 5 with the “Contribution towards your intellectual growth”. A lot of teamwork and problem solving activities are in this program.

84.4% of the respondents selected 1 or 2 on a scale of 5 with the “Clarity of course goals and learning objectives”. Students understand what they can expect to do upon completion of the class.

84.4% of the respondents selected 1 or 2 on a scale of 5 with the “Feedback and assessment of progress towards learning objectives”. Students could, and in one instance did, grade themselves on the class. There have been very few disagreements with students over a grade in their class.

80.6% of the respondents selected 1 or 2 on a scale of 5 with the “The content of courses offered in the Machining and Manufacturing Program”. The content of the program closely mirrors what many see in their place of employment.

**State at least three negative factors about the discipline/program identified by students. Include the number (or percentage) of students responding and any implications for planning.**

65.7% of the respondents selected 1 or 2 on a scale of 5 with the “The way textbooks and other materials used in courses within the program help me learn”. This is a reflection on the difficulty of locating quality textbooks in machine technology.

60.9% of the respondents selected 1 or 2 on a scale of 5 with the “Advice about the program from counselors”. This is a reflection on the need for more counselors dedicated to the CTE programs.

54.9% of the respondents selected 1 or 2 on a scale of 5 with the “The availability of courses offered in the Machining and Manufacturing program”. The addition of a second CAD lab will ease the congestion in scheduling those classes when we only had one CAD lab available.

74% of the respondents selected 1 or 2 on a scale of 5 with the “The coordination of courses offered in the Machining and Manufacturing Program and courses offered in other departments that may be required for your major”. In 2013-2014, most of the MT courses were modified to become CSU transferable credits. This could open up many of our classes to students intending to transfer to state universities.

48.4% of the respondents selected 1 or 2 on a scale of 5 with the “The physical facilities and space (e.g., classrooms, labs)”. Completion of the new Industrial Technology building has addressed this shortcoming.

64.5% of the respondents selected 1 or 2 on a scale of 5 with the “Instructional equipment (e.g., computers, lab equipment)”. None of the antique equipment from the old CBC lab was moved to the new building. It was all replaced by new equipment obtained through the IDRC grant.

50% of the respondents selected 1 or 2 on a scale of 5 with the “Course assistance through tutorial services (e.g. through the Tutorial Center, Math Lab, Writing Center). Interdisciplinary instruction and coordination remains an urgent need, particularly in programs housed in Industrial Technology. Change needs to be led by the Chief Instructional Officer.

61.1% of the respondents selected 1 or 2 on a scale of 5 with the “Availability of appropriate resources in the libraries”. The department secretary recently placed a copy of every current textbook in the AHC library.

**Part II of the Student Survey: Please Answer the Following Questions about the Machining and Manufacturing Program**

Which of the following best describes your reason for taking this and other courses in the Machining and Manufacturing Program?

Recommended by a counselor 3.1% n=32

Recommended by a friend 3.1%

To meet general education requirements 12.5%

Offered at a convenient time 0%

Employment and Job Skills 75%

Other 6.3%

Compared to the beginning of the semester, by the end of the semester, your attitude about the Machining and Manufacturing Program

Improved 81.3% n=32

Remained the same 12.5%

Decreased 6.3%

I would recommend taking courses in the Machining and Manufacturing Program.

Strongly agree 1	2	3	4	Strongly disagree 5
84.4%	3.1%	12.5%	0%	0%

n=32

av.=1.28

md=1

dev.=0.68

I plan on taking additional courses in the Machining and Manufacturing Program.

Strongly agree 1	2	3	4	Strongly disagree 5
68.8%	6.3%	21.9%	0%	3.1%

n=32

av.=1.63

md=1

dev.=1.04

I have earned a degree or certificate in the Machining and Manufacturing Program

Yes 28.1% n=32

No 71.9%

Which of the following courses have you taken in the Machining and Manufacturing Program?

MT109 Survey of Machining 81.3% n=32  
MT110 or MT179 CNC Principles and Practices 1 68.8%  
MT111 or MT179 CNC Principles and Practices 2 40.6%  
MT314 CNC Principles and Practices 3 28.1%  
MT311 Mastercam 43.8%  
MT379G Manufacturing Operations and Logistics 25%  
MT379I Applied Metrology 18.8%  
MT313 or MT379F SolidWorks 40.6%  
MT330 Blueprint Reading and Interpretation 40.6%  
MT381 Industrial Math 56.3%

**Part III of the Student Survey: Background Questions**

How many units have you completed prior to this semester?

0 - 15 34.4% n=32  
16 - 30 9.4%  
31 - 45 12.5%  
46 - 60 15.6%  
61 or more 28.1%

In how many units will you register for in the Fall 2014 semester?

less than 5 34.5% n=29  
5 - 8.5 27.6%  
9 - 11.5 17.2%  
12 or more 20.7%

What is your final academic goal?

Certificate 12.5% n=32  
AA/AS 37.5%  
Bachelors 25%  
Masters or higher 12.5%  
Not certain 12.5%

# COURSE REVIEW VERIFICATION

Discipline: Machining and Manufacturing Technology Year: 2015-2016

Program/Discipline Machining and Manufacturing Technology

As part of the program evaluation process, the self-study team has reviewed the course outlines supporting the discipline/program curriculum. The review process has resulted in the following recommendations:

1. The following course outlines are satisfactory as written and do not require modification (list all such courses):  
MT 109 – Survey of Machining  
MT 113 – SolidWorks 1  
MT 114 – SolidWorks 2  
MT 115 – Lean Manufacturing  
MT 116 – Mastercam  
MT 117 – Print Reading and Interpretation  
MT 118 – Understanding and Measuring GD&T  
MT 300 – Shop Math and Measurement  
MT 301 – Introduction to Safety  
MT 302 – Quality & Process Improvement  
MT 370 – SkillsUSA
2. The following courses require minor modification to ensure currency. It is anticipated that such minor modifications will be completed by Fall 2016.  
MT 303 – Mfg. Processes and Production  
MT 304 – Maintenance Awareness
3. The following courses require major modification. The self study team anticipates submitting such modifications to the AP&P committee, FALL 20 18 SPRING 20 \_\_\_\_  
MT 110 – CNC Principles and Practices 1 (change title to MT 110 CNC G CODE)  
MT 111 – CNC Principles and Practices 2 (change title to MT 110 CNC CAD-CAM)  
MT 112 – CNC Principles and Practices 3 (change title to MT 110 CNC MULTI-AXIS)  
MT 305 – Select Machine Projects  
MT 311 – Mastercam 1 (CAD/CAM)  
MT 312 – Lean Manufacturing  
MT 313 – SolidWorks 1  
MT 314 – CNC Principles and Practices 3  
MT 315 – Advanced Machining  
MT 330 – Print Reading & Interpretation  
MT 331 – Understanding/Measuring GD&T

## GENERAL EDUCATION or MULTICULTURAL/GENDER COURSES

The following courses were also reviewed as meeting an AHC general education requirement and were found to satisfactorily meet the established criteria (list courses by prefix & number):

The following courses were also reviewed as meeting an AHC general education requirement and will require modification to ensure the content reflects compliance with category definitions (list courses by prefix & number). It is anticipated that such modifications will be completed by:

(date) \_\_\_\_\_

The following courses were also reviewed as meeting the multicultural/gender graduation requirement and were found to satisfactorily meet the established criteria (list courses by prefix & number):

The following courses were also reviewed as meeting the multicultural/general graduation requirement and will require modification to ensure the content reflects compliance with category definitions (list courses by prefix & number). It is anticipated that such modifications will be completed by:

(date) \_\_\_\_\_

## Course Review Team Members:

Robert Mal 2/25/16  
Signature Date

\_\_\_\_\_  
Signature Date

\_\_\_\_\_  
Signature Date

\_\_\_\_\_  
Signature Date  
2-24-16  
Signature Academic Dean Date

## 2. Review Of Prerequisites, Corequisites, and Advisories

List all courses in Discipline/Program

Course Prefix No	CURRENT Prereq/Coreq/Advisory/ Limitation on Enrollment	LEVEL OF SCRUTINY (Statistics, Content Review, UC/CSU Comparison, Student Survey – list all)	RESULT (i.e., current PCA is established, should be dropped/modified or new PCA is established)	ACTION TO BE TAKEN (None, APP-Major or Minor)
MT 109	none	n/a	n/a	none
MT 110	Advisory MT 109	Content Review	Keep Current Advisory	none
MT 111	Advisory MT 110	Content Review	Change to Advisory MT 109	none
MT 112	Advisory MT 111	Content Review	Keep Current Advisory	none
MT 113	none	n/a	n/a	none
MT 114	Advisory MT 113	Content Review	Keep Current Advisory	none
MT 115	none	n/a	n/a	none
MT 116	none	n/a	n/a	none
MT 117	none	n/a	n/a	none
MT 118	Advisory MT 117	Content Review	Keep Current Advisory	none
MT 300	none	n/a	n/a	none

MT 301	none	n/a	n/a	none
MT 302	none	n/a	n/a	none
MT 303	none	n/a	n/a	none
MT 304	none	n/a	n/a	none
MT 370	none	n/a	n/a	none

Note: If prerequisite or corequisite is being established for the first time, course must be modified to include entrance skills.

### 3. Degree and Certificate Requirements

#### **MACHINING AND MANUFACTURING TECHNOLOGY (A.S. & Certificate of Achievement)**

#### Required core courses (18 units):

<b>COURSE NUMBER</b>	<b>TITLE</b>	<b>UNITS</b>
<b>MT 109</b>	<b>Survey of Machining and Manufacturing</b>	<b>4</b>
An introduction to machining and manufacturing technology where students will learn basic tool geometry, blueprint reading, shop math, precision measuring tools, co-ordinate systems and how to safely operate of a variety of industrial equipment.		
<b>MT 110</b>	<b>CNC Principles and Practices 1</b>	<b>4</b>
An introduction to computer-numerical-controlled (CNC) programming where students will learn to program, set-up and operate two and three axis CNC machines using the Cartesian coordinate system, G-codes (preparatory commands) and M-codes (miscellaneous commands).		
<b>MT 111</b>	<b>CNC Principles and Practices 2</b>	<b>4</b>
An intermediate course in computer-numerical-controlled (CNC) machining where students will learn to set-up, operate and program CNC machines using Mastercam computer-aided-design/computer-aided-manufacturing software (CAD/CAM).		
<b>MT 115</b>	<b>Lean Manufacturing</b>	<b>3</b>

An introduction to the theory and practice of continuous improvement where students will learn to identify and eliminate waste, improve quality and increase efficiency in every area of manufacturing operations. Students will participate in an actual Kaizen (or continuous improvement) event to make a change for the better in a real world setting.

**MT 117                      Print Reading and Interpretation                      3**

An introductory class where students will learn to read engineering drawings, evaluate print specifications, recognize orthographic views and visualize the actual objects or projects shown in the illustration.

**Plus a Minimum of 12 units selected from the following:**

<b>COURSE NUMBER</b>	<b>TITLE</b>	<b>UNITS</b>
----------------------	--------------	--------------

<b>MT 112</b>	<b>CNC Principles and Practices 3</b>	<b>4</b>
---------------	---------------------------------------	----------

An advanced course in computer-numerical-controlled (CNC) machining where students will learn to design complex parts using Mastercam and produce them on 4 and 5 axis CNC milling machines and lathes with “live tooling.”

<b>MT 113</b>	<b>SolidWorks 1</b>	<b>3</b>
---------------	---------------------	----------

An introduction to three dimensional computer-aided-design (CAD) where students will learn to design complex objects using SolidWorks. At the end of the course, students will be prepared for the Certified SolidWorks Associate (CSWA) assessment.

<b>MT 114</b>	<b>SolidWorks 2</b>	<b>3</b>
---------------	---------------------	----------

An advanced course in three dimensional computer-aided-design (CAD) where students will learn to design complex assemblies from individual components using SolidWorks. Students will learn to simulate the function of these assemblies. Includes an introduction to the SolidWorks stress analysis function.

<b>MT 116</b>	<b>Mastercam</b>	<b>3</b>
---------------	------------------	----------

An introduction to Mastercam, a leading software for computer-aided-design/computer-aided-manufacturing (CAD/CAM). Students will learn to create lines and arcs, simple surfaces and solids. Students will create tool paths and machine code for CNC lathes, mills and routers.

<b>MT 118</b>	<b>Understanding and Measuring GD&amp;T</b>	<b>3</b>
---------------	---	----------

An advanced class where students will learn to interpret complex manufacturing specifications, symbols and standards, including those referred to as Geometric Dimensioning and Tolerancing (GD&T). Students will evaluate components using a coordinate measuring machine and learn to generate accurate inspection reports.

<b>MT 300</b>	<b>Shop Math and Measurement</b>	<b>3</b>
---------------	----------------------------------	----------



An introduction to the mathematics used at work. Students will learn to solve problems using fractions, decimals, percentage, ratios and basic geometric shapes. Students will learn about the Cartesian coordinate system and how to use a variety of basic and precision measuring tools from rulers and tape measures to calipers and micrometers.

**MT 301 Introduction to Safety 2**

An introduction to manufacturing safety principles and practices. Students will learn about Material Safety Data Sheets (MSDS), work in confined space, lock out/tag out, zero energy state, hazardous materials, storage of flammable materials, storage of fuel gas and high pressure gas cylinders, portable powered tool safety, hand tool safety, record keeping, training, employer enforcement of safety regulations, and employee right to know.

**MT 302 Quality & Process Improvement 2**

An introduction to quality practices in manufacturing. Students will learn to read and interpret blueprints, understand Geometric Dimensioning and Tolerancing (GD&T), use essential measuring tools, perform root cause failure analysis, adopt methods of process improvement and employ statistical tools.

**MT 303 Mfg. Processes and Production 2**

An introduction to manufacturing procedures, practices and principles. Students will learn about mechanical principles, machining operations and tooling, production materials and documentation, manufacturing planning, production control, inventory management and product distribution.

<b>COURSE NUMBER</b>	<b>TITLE</b>	<b>UNITS</b>
----------------------	--------------	--------------

**MT 304 Maintenance Awareness 2**

An introduction to manufacturing maintenance awareness. Students will learn about basic electrical circuits, electrical, pneumatic and hydraulic power systems, lubrication concepts, bearings and couplings, belt and chain drives and the concepts of machine control and automation.

**MT 370 Skills USA 3**

SkillsUSA is a partnership of students, teachers and industry working together to ensure America has a skilled workforce. This SkillsUSA course prepares students for employment and inter-collegiate competition in Career Technical Education.

Students will learn to plan projects, work in teams, solicit community support and develop a range of skills valued by employers.

This course may be repeated three times.

## VI. ADVISORY COMMITTEE

When funds were needed to underwrite the MT faculty position, the advisory committee, chaired by Scott Barton of Gavial Engineering in Santa Maria, developed the following plan to accomplish its goals:

AHC Machine Technology

9/27/11

Next step notes

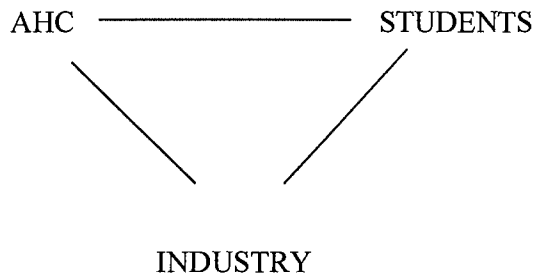

Need to strike a balance/partnership between industry, AHC, and students. All have a vested interest in this program's success.

- Industry – get trained workforce
- AHC – offer relevant courses, get students in the seats
- Students – improved employment opportunities after completing coursework

All parties must work together for continued growth of the program.

Industry – financial assistance, coursework planning & assistance in classroom, road show to high schools to market area manufacturing and the AHC MT program.

AHC – provide commitment to program, instructor, funding for both. Team with industry on the marketing of the program and area manufacturing to high schools in area.

Students – need to be educated on the MT program, courses, and benefits post certification –exciting, interesting and good paying jobs with growth potential.

Focus areas for Industry:

Financial assistance – need to raise \$83,000 / year for 3 years – best case scenario.

Need to tie into the Foundation (Jeff?) to get money going to the right places.

Companies can also provide equipment, materials, etc.

Coursework – suggestions, help build the course plan, take active role in classroom and out of classroom interactions, i.e. invite students to our facilities

Marketing - Need to put together a 'road show' to market local industry offerings, technology, bells and whistles, growth potential, jobs available, pay scale. This c/should be facilitated with the assistance of Jim Souza, Santa Lucia Regional Occupational Program, and Tony Bauer, SB County Regional Occupational Program.

Goal: Dispel the antiquated notion of what machining and manufacturing is, thus driving more students to the MT Program, and into the local workforce

**Machining and Manufacturing Demographic Notes:**

A quick search in the 'local' area reveals some interesting numbers:

Machine Shops in SB, SLO and Ventura counties:

<u>COUNTY</u>	
SLO :	43
SB :	52
Ventura :	<u>139</u>
Total:	234 (*)

(\*) Of these 234 shops, thirty two (32) have reported annual sales in excess of \$2.5mm.

Manufacturing Firms reporting annual sales in excess of \$20mm:

<u>COUNTY</u>	
SLO:	29
SB:	47
Ventura:	<u>113</u>
Total:	189

Looking a bit to the east, Bakersfield / Fresno area manufacturing firms with reported annual sales in excess of \$50mm:

Count: 63

Annual sales in excess of \$20mm and \$50mm provide a look at the larger manufacturing companies in their representative areas. These could be major employers that could direct benefit from graduates of the MT program at AHC.

# SECTION 8

EXECUTIVE SUMMARY

AND

PLAN OF ACTION

POST-VALIDATION

Coursework – suggestions, help build the course plan, take active role in classroom and out of classroom interactions, i.e. invite students to our facilities

Marketing - Need to put together a 'road show' to market local industry offerings, technology, bells and whistles, growth potential, jobs available, pay scale. This c/should be facilitated with the assistance of Jim Souza, Santa Lucia Regional Occupational Program, and Tony Bauer, SB County Regional Occupational Program.

Goal: Dispel the antiquated notion of what machining and manufacturing is, thus driving more students to the MT Program, and into the local workforce

**Machining and Manufacturing Demographic Notes:**

A quick search in the 'local' area reveals some interesting numbers:

Machine Shops in SB, SLO and Ventura counties:

**COUNTY**

SLO : 43

SB : 52

Ventura : 139

Total: 234 (\*)

(\*) Of these 234 shops, thirty two (32) have reported annual sales in excess of \$2.5mm.

Manufacturing Firms reporting annual sales in excess of \$20mm:

**COUNTY**

SLO: 29

SB: 47

Ventura: 113

Total: 189

Looking a bit to the east, Bakersfield / Fresno area manufacturing firms with reported annual sales in excess of \$50mm:

Count: 63

Annual sales in excess of \$20mm and \$50mm provide a look at the larger manufacturing companies in their representative areas. These could be major employers that could direct benefit from graduates of the MT program at AHC.

# SECTION 8

EXECUTIVE SUMMARY

AND

PLAN OF ACTION

POST-VALIDATION

**PROGRAM REVIEW -- VALIDATION TEAM MEMBERS**

TO: Academic Dean

Date: \_\_\_\_\_

From: Robert Mabry

We recommend the following persons for consideration for the validation team:

DEPARTMENT Industrial Technology PROGRAM Machining and Manufacturing Technology

Board Policy requires that the validation team be comprised of the dean of the area, one faculty member from a related discipline/program, and two faculty members from unrelated disciplines.

**Dominic Dal Bello**

(Name)

**Engineering**

(Related Discipline/Program)

**Patrick McGuire**

(Name)

**Automotive Technology**

(Unrelated Discipline/Program)

**Michael Dempsey**

(Name)

**Drama**

(Unrelated Discipline/Program)

At the option of the self-study team, the validation team may also include one or more of the following: a. someone from a four-year institution in the same discipline; someone from another community college in the same discipline; a high school instructor in the same discipline; a member of an advisory committee for the program. Please complete the following as relevant to your program review.

_____	_____
(Name)	(Title)
Affiliation: _____ Telephone Contact Number: _____	
Address _____	
(Mailing)	City/State/Zip email address

_____	_____
(Name)	(Title)
Affiliation: _____ Telephone Contact Number: _____	
Address _____	
(Mailing)	City/State/Zip email address

_____	_____
(Name)	(Title)
Affiliation: _____ Telephone Contact Number: _____	
Address _____	
(Mailing)	City/State/Zip email address

APPROVED:   
Academic Dean

2-24-16  
Date

**PLAN OF ACTION - PRE-VALIDATION  
Six Year**

DEPARTMENT: Industrial Technology PROGRAM: Machining and Manufacturing Technology

List below as specifically as possible the actions which the department plans to take as a result of this program review. Be sure to address any problem areas which you have discovered in your analysis of the program. Number each element of your plans separately and for each, please include a target date. Additionally, indicate by the number each institutional goal and objective which is addressed by each action plan. (See Institutional Goals and Objectives)

<b>RECOMMENDATIONS TO IMPROVE STUDENT LEARNING OUTCOMES AND ACHIEVEMENT</b>	<b>Theme/Objective/ Strategy Number AHC from Strategic Plan</b>	<b>TARGET DATE</b>
Update Course SLOs	SLS-1	2016-2021

<b>RECOMMENDATIONS TO ACCOMMODATE CHANGES IN STUDENT CHARACTERISTICS</b>	<b>Theme/Objective/ Strategy Number AHC from Strategic Plan</b>	<b>TARGET DATE</b>
<b>Enrollment Changes</b> Annual high school robotics workshops National Manufacturing Day tours	SLS-7 SLS-7	2016-2021 2016-2021
<b>Demographic Changes</b> Develop and pilot Ready Tech noncredit workforce readiness program targeting female and English Language Learners	SLS-3	2016-2017

<b>RECOMMENDATIONS TO IMPROVE THE EDUCATIONAL ENVIRONMENT</b>	<b>Theme/Objective/ Strategy Number AHC from Strategic Plan</b>	<b>TARGET DATE</b>
<b>Curricular Changes</b> Major Course Modifications	IR-3	2016-2021



Develop Rapid-Prototyping capability with additional 3D printers and laser engraving machines	IR-3	2016-2021
<b>Co-Curricular Changes</b>		
<b>Neighboring College and University Plans</b>		
<b>Related Community Plans</b>		
Manufacturing and Education Summit	I1	2016-2021
Modify Degrees and Certificates, recruit advisors and employ	I1	2016-2021

**RECOMMENDATIONS THAT REQUIRE ADDITIONAL RESOURCES**

**Theme/Objective/ Strategy Number AHC from Strategic Plan**

**TARGET DATE**

<b>Facilities</b>		
<b>Equipment</b>		
Acquire emerging technologies such as 3D printers and laser engraving machines	IR-3	2016-2021
Repair and Maintain computers and computer-controlled equipment	IR-2	2016-2021
Identify new and replacement equipment needs.	IR-3	2016-2021
Continue to seek resources for funds (CTEA Grant Application, equipment prioritization)	IR-3	2016-2021
Computer software maintenance agreements	IR-3	2016-2021
Inventory and write Surplus Property forms	G3	2016-2021
Clarify processes to simplify deposits from surplus disposal	G3	2016-2021
<b>Staffing</b>		
Recruit and train full time faculty	IR-1	8/19
Recruit and train part time faculty	IR-1	2016-2021

**EXECUTIVE SUMMARY**  
**(Validation Team Report)**

1. **MAJOR FINDINGS**

**Strengths of the program/discipline:**

The program has shown significant growth over the last 5 years. The program has established valuable relationships in the industry and has been innovative and responsive to employer needs with contract education, on-line courses and hosting of seminars.

**Faculty**

- The MT program has made a significant turn-around since the filling of the full time faculty position. This is reflected in: Increased FTES, established and active advisory committee, new and innovative curriculum, major financial support (\$500K+) from industry and student accomplishments.

**Facilities**

- The recent move into the new Industrial Technology building has provided more instructional space for labs and classrooms. This has dramatically changed the educational experience for students.
- State of the art technology and facilities, with the exception of not completed items.
- Purchased and updated equipment in the program by successfully using CTEA and IDRC grant funds, equipment prioritization and donations over the past several years.

**Enrollment**

- Since 2009-2010 academic year program's FTES numbers doubled by 2013-2014.
- Since fall 2009, MT program retention and success rates have improved and are consistently higher than the college's overall.
- Program's demographic data shows more than 50% of Hispanic student population and an unusually high representation of older students.
- Student survey showed that more than 84% of students would recommend taking courses in the program and more than 80% of students have improved their attitude compared to the beginning of the semester.
- The program is actively reaching out to recruit students from High Schools and industry.
- Due to an exceptional collaboration with a CTE counselor David Hernandez, degree and certificate attainment have been dramatically increased. Concerns of the Program

### **Concerns regarding the program/discipline:**

- Although the only full-time faculty plans to retire before the next program review, there is no plan on how prepare a successor for the coordination of the program.
- There is a lack of instructors in the area who meet the Minimum Qualifications to teach classes within the discipline. The program needs to develop a dependable and stable pool of part time instructors.
- The high school articulation process appeared to be broken at the institutional level and is in need of immediate repair, which will assume a renewal of former agreements.
- The Banner software that the college uses does not recognize articulated courses with feeder high schools. This creates barriers when students register for classes.
- Department clerical supports continues to be an issue especially with a part time secretary.
- The program needs improved support in the areas of counseling, contract and community education and business services.
- The program needs an organized and systematic approach to equipment updates and acquisitions — obsolete equipment should be able to be sold with proceeds going directly back to the program for new equipment.
- The program needs resources and support to maintain relationships with local and regional employers through seminar and event hosting.
- The program needs resources and support to maintain its outreach efforts to local K-12 schools.

## **2. RECOMMENDATIONS**

- The program works closely with the Counseling department to ensure student success..
- The program develops tracking method for students transferring to four-year institutions and continues to work with Cal Poly to develop articulation agreements.
- The program continues to maintain currency in technology, equipment and skills.
- The program seeks sustainable sources of funding for high school outreach events, externships and other needs of the program.
- The program continues to develop its relationship with HAAS Automation and expand and promote its activities as a Haas Technical Education Center (HTEC).
- The program develop a sample student completion plan.
- That the faculty continue to work closely with other programs in Industrial Technology to ensure that the department secretary position is changed to full-time.

**PLAN OF ACTION – POST-VALIDATION**  
(Sixth-Year Evaluation)

DEPARTMENT Industrial Technology PROGRAM Machining and Manufacturing Technology

In preparing this document, refer to the Plan of Action developed by the discipline/program during the self-study, and the recommendations of the Validation Team. Note that while the team should strongly consider the recommendations of the validation team, these are recommendations only. However, the team should provide a rationale when choosing to disregard or modify a validation team recommendation.

Identify the actions the discipline/program plans to take during the next six years. Be as specific as possible and indicate target dates. Additionally, indicate by the number each institutional goal and objective which is addressed by each action plan. (See Institutional Goals and Objectives) The completed final plan should be reviewed by the department as a whole.

Please be sure the signature page is attached.

RECOMMENDATIONS TO IMPROVE DESIRED STUDENT OUTCOMES AND IMPROVE STUDENT PERFORMANCE	Theme/Objective/ Strategy Number AHC from Strategic Plan	TARGET DATE
Modify Course SLOs – the SLOs were developed a few years ago and some have shown to need adjustments. The program thought the SLOs were appropriate when written but experience has shown that some of the outcomes exceeded the parameters of a semester long class while others have fallen short of what is possible for students to be able to do at the end of a class.	SLS-1	2016-2021

RECOMMENDATIONS TO ACCOMMODATE CHANGES IN STUDENT CHARACTERISTICS	Theme/Objective/ Strategy Number AHC from Strategic Plan	TARGET DATE
<b>Enrollment Changes</b> The program will continue to host National Manufacturing Day activities and tours as an effective means to introduce high school students to manufacturing careers and recruit for the program.	SLS-3	2016-2021
<b>Demographic Changes</b> Develop and pilot the Ready Tech noncredit workforce readiness program with its emphasis on female and English Language Learners. Support for this program is being sought from the National Science Foundation, the Title V Hispanic Serving Institution grant and AB 104 funds.	SLS-3	2016-2017

RECOMMENDATIONS TO IMPROVE THE EDUCATIONAL ENVIRONMENT	Theme/Objective/ Strategy Number AHC from Strategic Plan	TARGET DATE
<b>Curricular Changes</b> Continue to update the curriculum in line with the changing needs of Industry.	IR-3	2016-2021
Develop the new MT 306 Machining Fundamentals course sought by the MT Advisory Committee	IR-3	2016-2017
<b>Co-Curricular Changes</b>		

<b>Neighboring College and University Plans</b> Continue to serve on the Board of Cal Poly's Central Coast Lean and partner with its Orfalea College of Business in the MT 115 Lean Manufacturing class Projects. The program will begin to explore ways to articulate its courses with Cal Poly and other CSUs.		2016-2021
<b>Related Community Plans</b> Continue hosting an annual Manufacturing and Education Summit. Work with the Santa Maria Valley Chamber of Commerce and its Economic Development Commission (EDC) and industry to rebuild the Santa Maria Valley Manufacturing Association.	II  II	2016-2021  2016-2021

**RECOMMENDATIONS THAT REQUIRE ADDITIONAL RESOURCES**

**Theme/Objective/  
Strategy Number  
AHC from Strategic  
Plan**

**TARGET  
DATE**

<b>Facilities</b>		
<b>Equipment</b> Stay current with industry needs by updating and maintaining equipment.	IR-3	2016-2021
Develop Rapid-Prototyping capability with additional 3D printers and laser engraving machines	IR-3	2016-2021
Repair and Maintain computers and computer-controlled equipment	IR-2	2016-2021
Identify new and replacement equipment needs	IR-3	2016-2021
Continue to seek resources for funds (CTEA Grant Application, equipment prioritization)	IR-2	2016-2021
Develop the means to sustain computer software maintenance agreements	IR-2	2016-2021
Clarify processes to simplify deposits from surplus disposal	IR-2	2016-2021
<b>Staffing</b> Develop a faculty succession plan.	IR-1	8/19
Assess, recruit and train part time faculty	IR-1	2016-2021
Support department efforts to have a full time secretary	IR-2	2016-2021
Utilize a strategic staffing, funding and hosting plan for annual high school robotics workshops	SLS-7	2016-2021

VALIDATION TEAM SIGNATURE PAGE

Michael J. Deasy

[Signature]

[Signature]

DJ Dal Bello

**PLAN OF ACTION – Post-Validation**

Review and Approval

Plan Prepared By

Robert Mabry Robert Mabry Date: 2/25/16

\_\_\_\_\_ Date: \_\_\_\_\_

\_\_\_\_\_ Date: \_\_\_\_\_

\_\_\_\_\_ Date: \_\_\_\_\_

\_\_\_\_\_ Date: \_\_\_\_\_

Reviewed:

Eric Mason, Department Chair, Industrial Technology  
Eric Mason Date: 2/25/16

\*Signature of Department Chair indicates approval by department of Plan of Action.

Reviewed:

Larissa Nazarenko, Dean of Academic Affairs  
Larissa Nazarenko Date: 2-24-16

Dr. George Railey, Vice President, Academic Affairs  
George Railey Date: 3/31/16

# Appendix A - 2014 MT Student Surveys





Survey Results

Part I. Please indicate how satisfied you are, in general, with the following aspects of the Machining and Manufacturing Program.

Quality of instruction within the program		<p>n=32 av.=1.66 md=1 dev.=0.87</p>
The way textbooks and other materials used in courses within the program help me learn		<p>n=32 av.=2.13 md=2 dev.=0.98</p>
Advice about the program from counselors		<p>n=23 av.=2.35 md=2 dev.=1.37 ab.=8</p>
The way this program meets your educational goals		<p>n=32 av.=1.75 md=1 dev.=1.02</p>
Contribution towards your intellectual growth		<p>n=32 av.=1.56 md=1 dev.=0.91</p>
Clarity of course goals and learning objectives		<p>n=32 av.=1.75 md=1 dev.=1.05</p>
Feedback and assessment of progress towards learning objectives		<p>n=32 av.=1.75 md=2 dev.=0.8</p>
The availability of courses offered in the Machining and Manufacturing program		<p>n=31 av.=2.39 md=2 dev.=1.23 ab.=1</p>
The content of courses offered in the Machining and Manufacturing Program		<p>n=31 av.=1.71 md=1 dev.=0.94 ab.=1</p>
The coordination of courses offered in the Machining and Manufacturing Program and courses offered in other departments that may be required for your major		<p>n=27 av.=1.85 md=2 dev.=0.82 ab.=5</p>

The physical facilities and space (e.g., classrooms, labs)

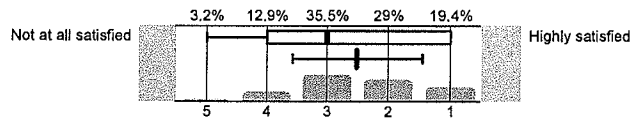

n=31  
av.=2.52  
md=3  
dev.=1.06  
ab.=1

Instructional equipment (e.g., computers, lab equipment)

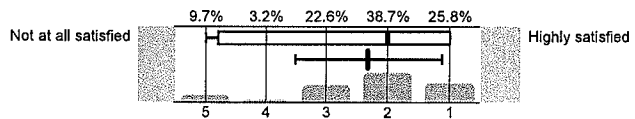

n=31  
av.=2.32  
md=2  
dev.=1.19  
ab.=1

Course assistance through tutorial services (e.g. through the Tutorial Center, Math Lab, Writing Center)

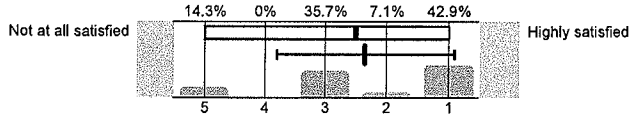

n=14  
av.=2.36  
md=2.5  
dev.=1.45  
ab.=16

Availability of appropriate resources in the libraries

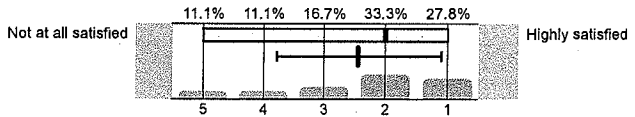

n=18  
av.=2.44  
md=2  
dev.=1.34  
ab.=13

**Part II. Please answer the following questions about the Machining and Manufacturing Program.**

Which of the following best describes your reason for taking this and other courses in the Machining and Manufacturing Program?

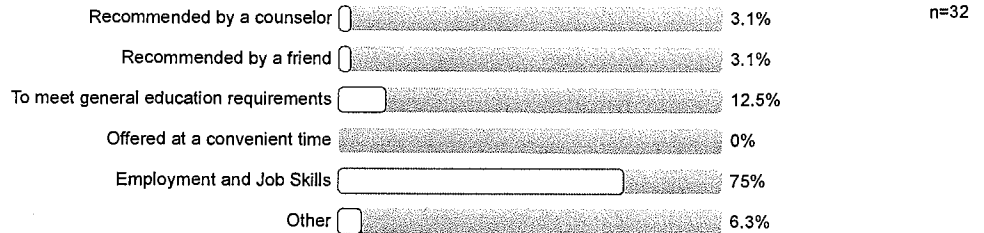

Compared to the beginning of the semester, by the end of the semester, your attitude about the Machining and Manufacturing Program



I would recommend taking courses in the Machining and Manufacturing Program.

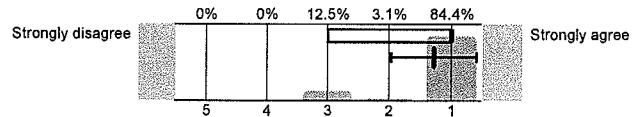

n=32  
av.=1.28  
md=1  
dev.=0.68

I plan on taking additional courses in the Machining and Manufacturing Program.

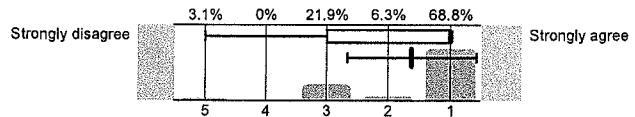

n=32  
av.=1.63  
md=1  
dev.=1.04

I have earned a degree or certificate in the Machining and Manufacturing Program



Which of the following courses have you taken in the Machining and Manufacturing Program?

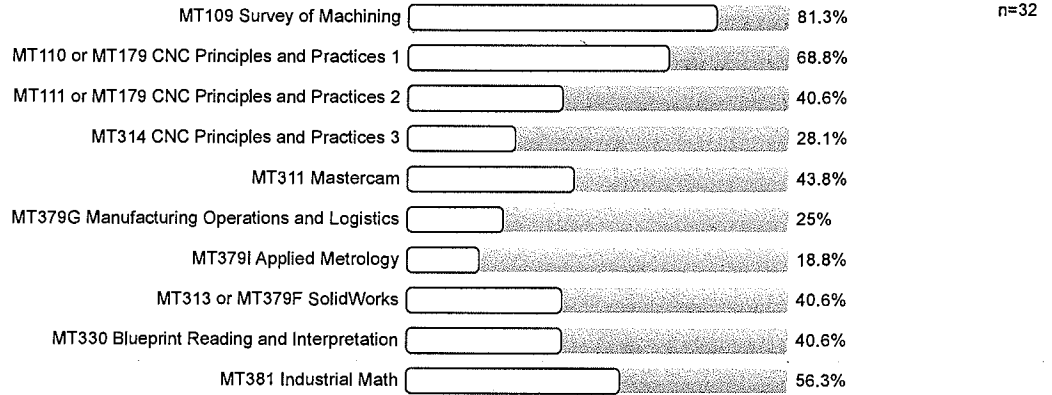

**Part III. Background Questions**

How many units have you completed prior to this semester?

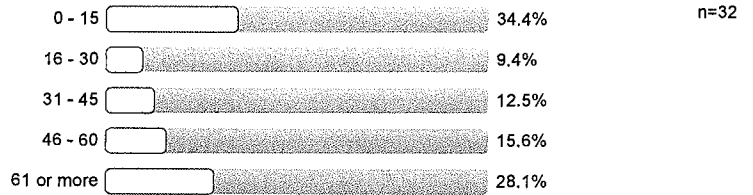

In how many units will you register for in the Fall 2014 semester?

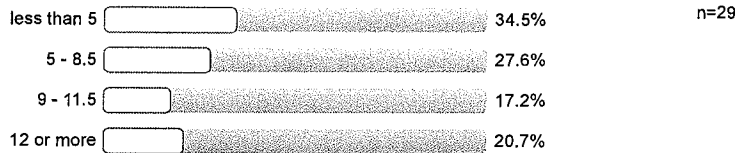

What is your final academic goal?

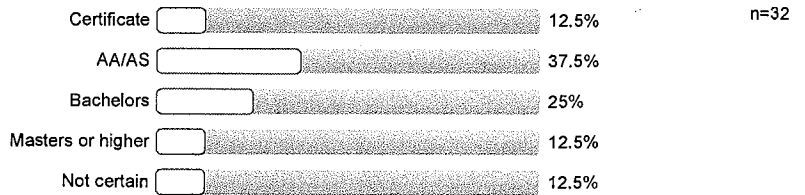

# Profile

Subunit: IR General Surveys  
 Name of the instructor: Program Review  
 Name of the course: Program Review Online Surveys  
 (Name of the survey)

Values used in the profile line: Mean

**Part I. Please indicate how satisfied you are, in general, with the following aspects of the Machining and Manufacturing Program.**

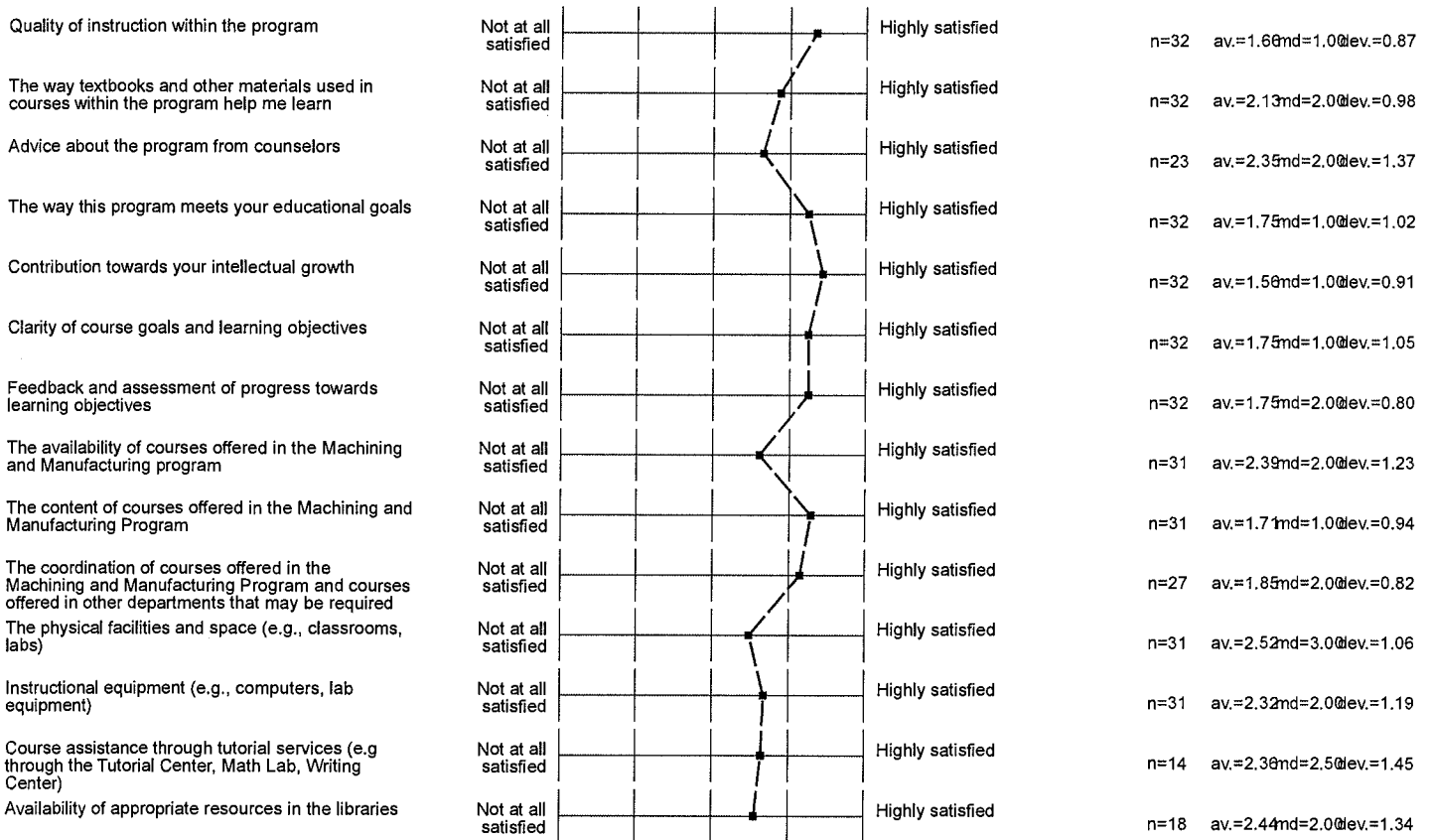

**Part II. Please answer the following questions about the Machining and Manufacturing Program.**

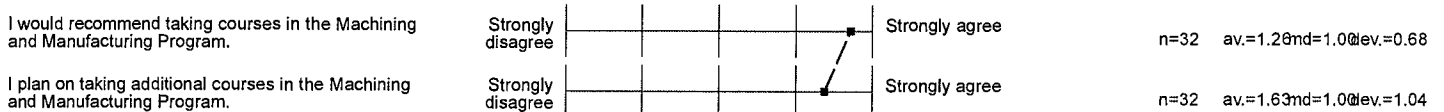

# Appendix B - IRP Program Review Data Set

2015-2016

Program Review Data

\*Machine Technology\*

# Table of Contents

Enrollment Data Summer 2009 – Spring 2015	1-6
Ethnicity & Gender Headcount Summer 2009 – Spring 2015	7-10
Age & Enroll Status Headcount Summer 2009 – Spring 2015	11-14
Degrees & Certificates Summer 2012 – Spring 2015	15-16
DL vs. F2F comparison Data/Graph Summer 2009 – Spring 2015	17-28
Efficiency Data/Graph Fall 2014 & Spring 2015	29-32

Summer 2009, Fall 2009, Spring 2010 and 6 more Enrollment, FTES, Retention & Success AHC Data

	Summer 2009	Fall 2009	Spring 2010	Summer 2010	Fall 2010	Spring 2011	Summer 2011	Fall 2011	Spring 2012
Sections	262	1,114	1,238	348	1,178	1,240	314	1,023	1,146
Headcount	4,637	11,253	12,728	6,230	12,131	12,689	5,798	10,957	11,736
Enrollment	7,161	29,913	32,406	10,179	32,211	33,109	9,242	29,219	30,988
Retention %	88.58%	87.98%	88.82%	84.71%	85.14%	84.72%	85.50%	86.69%	84.65%
Success %	77.55%	68.49%	72.75%	72.20%	67.32%	68.82%	74.32%	68.63%	69.09%
FTES	940	4,036	4,688	1,249	4,239	4,162	1,072	3,905	3,879



Fall 2009, Spring 2010, Summer 2010 and 5 more MT Outcomes

	Fall 2009	Spring 2010	Summer 2010	Fall 2010	Spring 2011	Summer 2011	Fall 2011	Spring 2012
Sections	3.0	9.0	2.0	7.0	7.0	2.0	6.0	8.0
Headcount	24.0	107.0	34.0	85.0	94.0	35.0	86.0	99.0
Enrollment	24.0	149.0	35.0	94.0	110.0	35.0	97.0	116.0
retained	19.0	141.0	31.0	79.0	102.0	32.0	87.0	103.0
Retention %	79.17%	94.63%	88.57%	84.04%	92.73%	91.43%	89.69%	88.79%
success	18.0	132.0	27.0	73.0	84.0	31.0	75.0	95.0
Success %	75.00%	88.59%	77.14%	77.66%	76.36%	88.57%	77.32%	81.90%
FTES	6.1	14.5	5.2	17.6	18.7	5.2	19.5	20.0

Fall 2009, Spring 2010, Summer 2010 and 5 more Retention & Success

\*Click on course name to get retention/success by course demographics\*

course	Fall 2009	Spring 2010	Summer 2010	Fall 2010	Spring 2011	Summer 2011	Fall 2011	Spring 2012	Measure Names
MT109	82%	100%	100%	91%	91%	86%	89%	76%	Retention %
MT110		100%						100%	Success %
MT179		84%							
MT179D				71%					
MT179E					94%				
MT179F							95%		
MT185								100%	
MT311					91%		72%		
MT312					100%			90%	
MT330	100%	100%		100%	71%			100%	
MT379	94%	94%							
MT379A			78%						
MT379D				85%					
MT379E				80%					
MT379F						95%		90%	
MT379G							100%		
MT381	50%	100%		100%	100%		100%	100%	
Grand Total	79%	95%	89%	84%	93%	91%	90%	89%	

Summer 2012, Fall 2012, Spring 2013 and 6 more Enrollment, FTES, Retention & Success AHC Data

	Summer 2012	Fall 2012	Spring 2013	Summer 2013	Fall 2013	Spring 2014	Summer 2014	Fall 2014	Spring 2015
<b>Sections</b>	293	1,004	1,087	285	1,069	1,141	306	1,141	1,209
<b>Headcount</b>	5,551	10,883	11,361	5,421	10,922	11,293	5,185	11,084	11,249
<b>Enrollment</b>	8,784	28,559	29,609	8,455	28,612	29,369	8,168	29,153	28,984
<b>Retention %</b>	89.79%	86.62%	86.17%	89.13%	86.97%	85.23%	89.37%	86.83%	85.44%
<b>Success %</b>	77.33%	69.63%	70.38%	77.46%	70.56%	70.22%	77.69%	69.80%	71.38%
<b>FTES</b>	1,001	3,775	3,813	978	3,852	3,868	944	3,900	4,048

Summer 2012, Fall 2012, Spring 2013 and 6 more MT Outcomes

	Summer 2012	Fall 2012	Spring 2013	Summer 2013	Fall 2013	Spring 2014	Summer 2014	Fall 2014	Spring 2015
<b>Sections</b>	1.0	6.0	7.0	1.0	5.0	8.0	1.0	7.0	8.0
<b>Headcount</b>	16.0	90.0	95.0	19.0	68.0	103.0	17.0	74.0	100.0
<b>Enrollment</b>	16.0	109.0	128.0	19.0	76.0	141.0	17.0	92.0	127.0
<b>retained</b>	16.0	93.0	118.0	19.0	70.0	118.0	17.0	82.0	110.0
<b>Retention %</b>	100.00%	85.32%	92.19%	100.00%	92.11%	83.69%	100.00%	89.13%	86.61%
<b>success</b>	16.0	80.0	104.0	17.0	62.0	112.0	14.0	72.0	101.0
<b>Success %</b>	100.00%	73.39%	81.25%	89.47%	81.58%	79.43%	82.35%	78.26%	79.53%
<b>FTES</b>	4.1	20.6	26.1	4.8	17.5	26.8	4.6	17.8	20.5

Summer 2012, Fall 2012, Spring 2013 and 6 more Retention & Success

\*Click on course name to get retention/success by course demographics\*

course	Summer 2012	Fall 2012	Spring 2013	Summer 2013	Fall 2013	Spring 2014	Summer 2014	Fall 2014	Spring 2015	Measure Names
MT109	100%	84%	93%	100%	92%	87%	100%	90%	82%	Retention %
MT110			93%			78%		84%	69%	Success %
MT111		95%						100%		
MT112									60%	
MT113									88%	
MT115									86%	
MT117								100%	100%	
MT179A									100%	
MT300								75%	100%	
MT301								81%		
MT311						75%				
MT313			83%			65%				
MT314					92%					
MT330			100%		91%	100%				
MT379G			95%			100%				
MT379H		84%								
MT379I		79%								
MT381		89%	100%		100%	100%				
MT389								100%		
Grand Total	100%	85%	92%	100%	92%	84%	100%	88%	87%	

Fall 2009, Spring 2010, Summer 2010 and 5 more Demographics MT

ETHNICITY	Fall 2009		Spring 2010		Summer 2010		Fall 2010		Spring 2011		Summer 2011		Fall 2011		Spring 2012	
	Headc.	FTES	Headc.	FTES	Headc.	FTES	Headc.	FTES	Headc.	FTES	Headc.	FTES	Headc.	FTES	Headc.	FTES
Asian			1.00	0.27	1.00	0.25	3.00	0.42	3.00	0.33	3.00	0.42	2.00	0.38		
Black			1.00	0.03			2.00	0.45					1.00	0.28	4.00	0.79
Filipono			3.00	0.18	3.00	0.56	3.00	0.56	2.00	0.42			3.00	0.46	4.00	0.64
Hispanic	7.00	1.88	34.00	4.50	15.00	2.60	32.00	6.37	44.00	9.86	16.00	2.26	46.00	10.47	43.00	9.39
Native Am							1.00	0.28	2.00	0.31						
Other			1.00	0.13	1.00	0.05	1.00	0.27	1.00	0.03						
Pacific Islander			1.00	0.13												
Unknown	2.00	0.54	5.00	0.46					2.00	0.12						
White	15.00	3.69	59.00	8.72	14.00	1.76	43.00	9.24	39.00	7.56	16.00	2.55	34.00	7.94	48.00	9.21

Fall 2009, Spring 2010, Summer 2010 and 5 more Demographics MT

Gender	Fall 2009		Spring 2010		Summer 2010		Fall 2010		Spring 2011		Summer 2011		Fall 2011		Spring 2012	
	Headc..	FTES	Headc..	FTES	Headc..	FTES	Headc..	FTES	Headc..	FTES	Headc..	FTES	Headc..	FTES	Headc..	FTES
Female			4.0	0.2	3.0	0.8	9.0	1.0	4.0	0.7	2.0	0.3	7.0	1.4	6.0	0.9
Male	24.0	6.1	100.0	14.1	30.0	4.4	76.0	16.6	88.0	17.5	33.0	4.9	78.0	17.9	93.0	19.2
Unknown			1.0	0.1	1.0	0.1			1.0	0.4			1.0	0.2		
<b>Grand Total</b>	<b>24.0</b>	<b>6.1</b>	<b>105.0</b>	<b>14.4</b>	<b>34.0</b>	<b>5.2</b>	<b>85.0</b>	<b>17.6</b>	<b>93.0</b>	<b>18.6</b>	<b>35.0</b>	<b>5.2</b>	<b>86.0</b>	<b>19.5</b>	<b>99.0</b>	<b>20.0</b>

Summer 2012, Fall 2012, Spring 2013 and 6 more Demographics MT

ETHNICITY	Summer 2012		Fall 2012		Spring 2013		Summer 2013		Fall 2013		Spring 2014		Summer 2014		Fall 2014		Spring 2015	
	Headc..	FTES	Headc..	FTES	Headc..	FTES	Headc..	FTES	Headc..	FTES	Headc..	FTES	Headc..	FTES	Headc..	FTES	Headc..	FTES
Asian			6.00	1.47	2.00	0.56	1.00	0.25	1.00	0.21	5.00	1.41			1.00	0.56	1.00	0.07
Black					3.00	0.96	1.00	0.25	1.00	0.32	2.00	0.51			1.00	0.21	2.00	0.34
Filipono			2.00	0.52	5.00	1.37	1.00	0.25	2.00	0.53	7.00	1.84			3.00	0.77		
Hispanic	4.00	1.02	45.00	10.51	44.00	13.77	6.00	1.52	34.00	8.60	41.00	10.83	10.00	2.72	35.00	8.42	47.00	9.47
Native Am			1.00	0.27					1.00	0.28	2.00	0.57			1.00	0.28	2.00	0.39
Pacific Islander					1.00	0.11											1.00	0.28
White	12.00	3.05	36.00	7.83	40.00	9.36	10.00	2.54	29.00	7.52	46.00	11.61	7.00	1.90	33.00	7.53	47.00	9.94



Summer 2012, Fall 2012, Spring 2013 and 6 more Demographics MT

Gender	Summer 2012		Fall 2012		Spring 2013		Summer 2013		Fall 2013		Spring 2014		Summer 2014		Fall 2014		Spring 2015	
	Headc..	FTES	Headc..	FTES	Headc..	FTES	Headc..	FTES	Headc..	FTES	Headc..	FTES	Headc..	FTES	Headc..	FTES	Headc..	FTES
Female			1.0	0.3	4.0	0.8			1.0	0.3	4.0	1.1	3.0	0.8	2.0	0.8	2.0	0.2
Male	16.0	4.1	89.0	20.3	91.0	25.4	19.0	4.8	67.0	17.2	99.0	25.7	14.0	3.8	72.0	17.0	98.0	20.3
Grand Total	16.0	4.1	90.0	20.6	95.0	26.1	19.0	4.8	68.0	17.5	103.0	26.8	17.0	4.6	74.0	17.8	100.0	20.5

Fall 2009, Spring 2010, Summer 2010 and 5 more Demographics MT

age_category	Fall 2009		Spring 2010		Summer 2010		Fall 2010		Spring 2011		Summer 2011		Fall 2011		Spring 2012	
	Headc..	FTES	Headc..	FTES	Headc..	FTES	Headc..	FTES	Headc..	FTES	Headc..	FTES	Headc..	FTES	Headc..	FTES
Under 19	6.00	1.62	13.00	1.73	9.00	2.29	16.00	3.79	11.00	2.86	8.00	1.71	20.00	4.57	16.00	3.19
20-24	7.00	1.54	19.00	4.20	4.00	0.41	25.00	4.68	20.00	4.15	8.00	0.89	21.00	5.12	27.00	5.83
25-29	2.00	0.53	15.00	2.20	3.00	0.39	12.00	3.04	14.00	2.07	2.00	0.35	20.00	4.62	14.00	2.66
30-34	2.00	0.54	13.00	2.19	5.00	0.87	10.00	1.94	10.00	2.42	3.00	0.42	4.00	0.74	12.00	2.69
35-39	1.00	0.27	8.00	0.59	4.00	0.41	6.00	1.55	9.00	2.13	2.00	0.51	4.00	0.81	6.00	1.07
40-49	5.00	1.33	25.00	2.13	6.00	0.51	8.00	1.41	16.00	2.74	5.00	0.60	6.00	1.32	10.00	1.87
50+	1.00	0.27	12.00	1.39	3.00	0.36	8.00	1.17	13.00	2.26	7.00	0.77	11.00	2.34	14.00	2.72

Fall 2009, Spring 2010, Summer 2010 and 5 more Demographics MT

Enrollment Status	Fall 2009		Spring 2010		Summer 2010		Fall 2010		Spring 2011		Summer 2011		Fall 2011		Spring 2012	
	Headc..	FTES	Headc..	FTES	Headc..	FTES	Headc..	FTES	Headc..	FTES	Headc..	FTES	Headc..	FTES	Headc..	FTES
First Time Student	5.0	1.4	17.0	1.5	13.0	2.5	23.0	6.1	19.0	3.6	3.0	0.4	17.0	3.4	11.0	2.6
First Time Transf..	1.0	0.3	15.0	0.9	4.0	0.8	5.0	1.0	10.0	0.7			3.0	0.8	7.0	1.2
Continuing	8.0	2.0	34.0	7.5	9.0	1.3	48.0	9.1	54.0	12.9	25.0	3.4	53.0	12.1	69.0	14.1
Returning	8.0	2.0	39.0	4.5	8.0	0.6	8.0	1.3	10.0	1.5	5.0	0.9	12.0	2.9	11.0	1.9
NA	2.0	0.5									2.0	0.5	1.0	0.3	1.0	0.3
Unknown							1.0	0.1								
Grand Total	24.0	6.1	105.0	14.4	34.0	5.2	85.0	17.6	93.0	18.6	35.0	5.2	86.0	19.5	99.0	20.0

Summer 2012, Fall 2012, Spring 2013 and 6 more Demographics MT

age_category	Summer 2012		Fall 2012		Spring 2013		Summer 2013		Fall 2013		Spring 2014		Summer 2014		Fall 2014		Spring 2015	
	Headc.	FTES	Headc.	FTES	Headc.	FTES	Headc.	FTES	Headc.	FTES	Headc.	FTES	Headc.	FTES	Headc.	FTES	Headc.	FTES
Under 19	6.00	1.52	10.00	2.74	8.00	2.33	5.00	1.27	6.00	1.77	12.00	3.20	1.00	0.27	11.00	2.48	7.00	1.54
20-24	6.00	1.52	23.00	5.93	36.00	11.16	5.00	1.27	27.00	6.94	30.00	7.82	7.00	1.90	24.00	6.69	25.00	4.76
25-29	1.00	0.25	23.00	4.96	19.00	4.79	3.00	0.76	18.00	4.63	20.00	4.93	4.00	1.09	20.00	4.73	27.00	5.23
30-34			8.00	1.90	5.00	1.16	3.00	0.76	5.00	1.20	9.00	3.32	1.00	0.27	10.00	2.55	18.00	4.20
35-39	1.00	0.25	9.00	1.76	9.00	2.22	1.00	0.25	3.00	0.43	13.00	3.80	1.00	0.27	5.00	0.58	6.00	1.56
40-49	1.00	0.25	9.00	1.70	10.00	2.91	1.00	0.25	1.00	0.29	13.00	2.10	3.00	0.82	1.00	0.26	6.00	1.01
50+	1.00	0.25	8.00	1.60	8.00	1.56	1.00	0.25	8.00	2.20	6.00	1.59			3.00	0.45	11.00	2.18

Summer 2012, Fall 2012, Spring 2013 and 6 more Demographics MT

Enrollment Status	Summer 2012		Fall 2012		Spring 2013		Summer 2013		Fall 2013		Spring 2014		Summer 2014		Fall 2014		Spring 2015	
	Headc.	FTES	Headc.	FTES	Headc.	FTES	Headc.	FTES	Headc.	FTES	Headc.	FTES	Headc.	FTES	Headc.	FTES	Headc.	FTES
First Time Student	2.0	0.5	13.0	3.5	10.0	4.3	6.0	1.5	11.0	2.9	9.0	2.3	4.0	1.1	13.0	3.1	6.0	1.1
First Time Transf..			8.0	1.6	7.0	2.0	2.0	0.5	4.0	1.1	12.0	2.7	1.0	0.3	4.0	1.0	7.0	2.1
Continuing	9.0	2.3	43.0	9.6	53.0	14.4	8.0	2.0	47.0	11.6	60.0	15.8	11.0	3.0	49.0	12.2	61.0	12.3
Returning	2.0	0.5	26.0	5.9	25.0	5.5	2.0	0.5	6.0	1.8	22.0	5.9	1.0	0.3	8.0	1.5	26.0	5.0
NA	3.0	0.8					1.0	0.3										
Grand Total	16.0	4.1	90.0	20.6	95.0	25.1	19.0	4.8	68.0	17.5	103.0	26.8	17.0	4.6	74.0	17.8	100.0	20.5

Degrees & Certificates

GRADUATION\_TERM\_CODE

DEGREE_PRO..	DEGREE_M..	DEGREE_CODE	Fall 2012	Spring 2013	Summer 2013	Fall 2013	Spring 2014	Fall 2014	Spring 2015	Grand Total
Machine Technology	General	AS							1	1
	Machining & Manufacturing Tech	AS Cert 18-30 Units	2		1		1	1	1	6
			2	5		1				8
	Total		4	5	1	1	1	1	2	15
Grand Total			4	5	1	1	1	1	2	15

Retention & Success for MT

course_type	course	Fall 2009			Spring 2010			Summer 2010			Fall 2010			Spring 2011		
		Sections	Enrollment	FTES	Sections	Enrollment	FTES	Sections	Enrollment	FTES	Sections	Enrollment	FTES	Sections	Enrollment	FTES
Face to Face Course	MT109	2.0	22.0	5.9	1.0	14.0	3.7	1.0	17.0	4.3	2.0	33.0	9.1	2.0	33.0	9.2
	MT110				1.0	16.0	4.3									
	MT179				2.0	19.0	1.2									
	MT179D										1.0	17.0	4.7			
	MT179E													1.0	16.0	4.5
	MT311													1.0	22.0	3.1
	MT312													1.0	27.0	0.7
	MT330				1.0	10.0	1.0				1.0	3.0	0.3	1.0	7.0	0.7
	MT379				3.0	87.0	3.9									
	MT379A							1.0	18.0	0.9						
	MT379D										1.0	20.0	0.6			
	MT379E										1.0	20.0	2.8			
	MT381	1.0	2.0	0.2	1.0	3.0	0.3				1.0	1.0	0.1	1.0	5.0	0.5
<b>Total</b>		<b>3.0</b>	<b>24.0</b>	<b>6.1</b>	<b>9.0</b>	<b>149.0</b>	<b>14.5</b>	<b>2.0</b>	<b>35.0</b>	<b>5.2</b>	<b>7.0</b>	<b>94.0</b>	<b>17.6</b>	<b>7.0</b>	<b>110.0</b>	<b>18.7</b>
<b>Grand Total</b>		<b>3.0</b>	<b>24.0</b>	<b>6.1</b>	<b>9.0</b>	<b>149.0</b>	<b>14.5</b>	<b>2.0</b>	<b>35.0</b>	<b>5.2</b>	<b>7.0</b>	<b>94.0</b>	<b>17.6</b>	<b>7.0</b>	<b>110.0</b>	<b>18.7</b>

**Retention & Success AHC**

course_type	Summer 2009			Fall 2009			Spring 2010			Summer 2010			Fall 2010			Spring 2011		
	Sectio..	Enroll..	FTES	Sectio..	Enroll..	FTES	Sectio..	Enroll..	FTES	Sectio..	Enroll..	FTES	Sectio..	Enroll..	FTES	Sectio..	Enroll..	FTES
Face to Face Course	261	7,150	940	1,105	29,834	4,029	1,215	32,313	4,679	348	10,179	1,249	1,172	32,135	4,223	1,178	31,018	3,966
Online Course	1	11	0	9	79	7	23	93	9				6	76	16	62	2,091	196
<b>Grand Total</b>	<b>262</b>	<b>7,161</b>	<b>940</b>	<b>1,114</b>	<b>29,913</b>	<b>4,036</b>	<b>1,238</b>	<b>32,406</b>	<b>4,688</b>	<b>348</b>	<b>10,179</b>	<b>1,249</b>	<b>1,178</b>	<b>32,211</b>	<b>4,239</b>	<b>1,240</b>	<b>33,109</b>	<b>4,162</b>



**Retention & Success for all AHC**

course_type	Summer 2009	Fall 2009	Spring 2010	Summer 2010	Fall 2010	Spring 2011	Measure Names
Face to Face Course	78%	79%	74%	72%	67%	70%	Retention %
Online Course	73%	75%	86%		74%	78%	Success %
Grand Total	76%	77%	80%	72%	70%	76%	

### Retention & Success MT

course_type	course	Fall 2009	Spring 2010	Summer 2010	Fall 2010	Spring 2011
Face to Face Course	MT109	52%	100%	76%	79%	76%
	MT110		88%			
	MT179		66%			
	MT179D				65%	71%
	MT179E					75%
	MT311					73%
	MT312					78%
	MT330		100%		100%	71%
	MT379		98%			
	MT379A			78%		
	MT379D				83%	85%
	MT379E				73%	80%
	MT381	50%	66%		100%	100%
	<b>Total</b>		75% 79%	89% 95%	77% 88%	78% 84%
<b>Grand Total</b>		75% 79%	89% 95%	77% 88%	78% 84%	78% 83%

Retention & Success for MT

course_type	course	Summer 2011			Fall 2011			Spring 2012			Summer 2012			Fall 2012			Spring 2013		
		Sections	Enrollment	FTEs	Sections	Enrollment	FTEs	Sections	Enrollment	FTEs	Sections	Enrollment	FTEs	Sections	Enrollment	FTEs	Sections	Enrollment	FTEs
Face to Face Course	MT109	1.0	14.0	3.6	2.0	37.0	10.2	2.0	37.0	9.9	1.0	16.0	4.1	2.0	31.0	8.6	2.0	43.0	12.3
	MT110							1.0	22.0	6.1							1.0	27.0	7.5
	MT111													1.0	22.0	4.7			
	MT179F				1.0	22.0	4.7												
	MT189							1.0	3.0	0.1									
	MT311				1.0	18.0	2.5												
	MT312							1.0	20.0	0.3									
	MT313																1.0	23.0	2.5
	MT330							1.0	9.0	1.0							1.0	8.0	0.9
	MT379F	1.0	21.0	1.7				1.0	20.0	2.1									
	MT379G				1.0	17.0	1.7										1.0	21.0	2.4
	MT379H													1.0	19.0	2.6			
	MT379I													1.0	28.0	3.8			
	MT381				1.0	3.0	0.3	1.0	5.0	0.5				1.0	9.0	1.0	1.0	6.0	0.6
	<b>Total</b>	<b>2.0</b>	<b>35.0</b>	<b>5.2</b>	<b>6.0</b>	<b>97.0</b>	<b>19.5</b>	<b>8.0</b>	<b>116.0</b>	<b>20.0</b>	<b>1.0</b>	<b>16.0</b>	<b>4.1</b>	<b>6.0</b>	<b>109.0</b>	<b>20.6</b>	<b>7.0</b>	<b>128.0</b>	<b>26.1</b>
	<b>Grand Total</b>	<b>2.0</b>	<b>35.0</b>	<b>5.2</b>	<b>6.0</b>	<b>97.0</b>	<b>19.5</b>	<b>8.0</b>	<b>116.0</b>	<b>20.0</b>	<b>1.0</b>	<b>16.0</b>	<b>4.1</b>	<b>6.0</b>	<b>109.0</b>	<b>20.6</b>	<b>7.0</b>	<b>128.0</b>	<b>26.1</b>

**Retention & Success AHC**

course_type	Summer 2011			Fall 2011			Spring 2012			Summer 2012			Fall 2012			Spring 2013		
	Sectio..	Enroll..	FTES	Sectio..	Enroll..	FTES	Sectio..	Enroll..	FTES	Sectio..	Enroll..	FTES	Sectio..	Enroll..	FTES	Sectio..	Enroll..	FTES
Face to Face Course	212	5,351	680	846	23,234	3,291	945	24,321	3,209	195	4,858	605	833	22,653	3,174	890	22,791	3,138
Online Course	102	3,891	391	177	5,985	614	201	6,667	670	98	3,926	396	171	5,906	601	197	6,818	675
<b>Grand Total</b>	<b>314</b>	<b>9,242</b>	<b>1,072</b>	<b>1,023</b>	<b>29,219</b>	<b>3,905</b>	<b>1,146</b>	<b>30,988</b>	<b>3,879</b>	<b>293</b>	<b>8,784</b>	<b>1,001</b>	<b>1,004</b>	<b>28,559</b>	<b>3,775</b>	<b>1,087</b>	<b>29,609</b>	<b>3,813</b>

**Retention & Success for all AHC**

course_type	Summer 2011	Fall 2011	Spring 2012	Summer 2012	Fall 2012	Spring 2013	Measure Names
Face to Face Course	80%	75%	75%	84%	73%	71%	Retention %
Online Course	80%	78%	76%	89%	79%	80%	Success %
Grand Total	80%	77%	76%	87%	76%	76%	

Retention & Success MT

course_type	course	Summer 2011	Fall 2011	Spring 2012	Summer 2012	Fall 2012	Spring 2013	Retention %	Success %
Face to Face Course	MT109	85%	86%	75%	76%	100%	100%	67%	88%
	MT110			100%	100%			81%	98%
	MT111					88%	95%		
	MT179F		88%	95%					
	MT189			100%	100%				
	MT311		58%	72%					
	MT312			55%	71%				
	MT313							71%	83%
	MT330			100%	100%				88%
	MT379F	90%	95%	90%	98%				
	MT379G		92%	100%					76%
	MT379H					84%	94%		
	MT379I					77%	79%		
	MT381		97%	100%	100%	100%	100%	100%	100%
		<b>Total</b>	89%	91%	87%	89%	100%	100%	73%
	<b>Grand Total</b>	89%	91%	87%	89%	100%	100%	73%	85%

Retention & Success for MT

course_type	course	Summer 2013			Fall 2013			Spring 2014			Summer 2014			Fall 2014			Spring 2015		
		Sections	Enrollment	FTEs	Sections	Enrollment	FTEs	Sections	Enrollment	FTEs	Sections	Enrollment	FTEs	Sections	Enrollment	FTEs	Sections	Enrollment	FTEs
Face to Face Course	MT109	1.0	19.0	4.8	2.0	37.0	10.6	2.0	39.0	11.2	1.0	17.0	4.6	1.0	20.0	5.6	1.0	22.0	6.1
	MT110							1.0	23.0	6.4				1.0	19.0	5.3	1.0	13.0	3.6
	MT111													1.0	18.0	3.8			
	MT112																1.0	15.0	3.2
	MT113																1.0	25.0	2.7
	MT115																1.0	21.0	2.2
	MT117													1.0	10.0	1.1	1.0	7.0	0.7
	MT179A																1.0	17.0	1.1
	MT300													1.0	8.0	0.9	1.0	7.0	0.7
	MT311								1.0	20.0	2.8								
	MT313								1.0	23.0	2.5								
	MT314					1.0	25.0	5.3											
	MT330					1.0	11.0	1.2	1.0	11.0	1.2								
	MT379G								1.0	17.0	1.9								
	MT381					1.0	3.0	0.3	1.0	8.0	0.9								
	MT389													1.0	1.0	0.1			
	<b>Total</b>	1.0	19.0	4.8	5.0	76.0	17.5	8.0	141.0	26.8	1.0	17.0	4.6	6.0	76.0	16.7	8.0	127.0	20.5
Online Course	MT301													1.0	16.0	1.0			
	<b>Total</b>													1.0	16.0	1.0			
<b>Grand Total</b>		1.0	19.0	4.8	5.0	76.0	17.5	8.0	141.0	26.8	1.0	17.0	4.6	7.0	92.0	17.8	8.0	127.0	20.5

**Retention & Success AHC**

course_type	Summer 2013			Fall 2013			Spring 2014			Summer 2014			Fall 2014			Spring 2015		
	Sectio..	Enroll..	FTES	Sectio..	Enroll..	FTES	Sectio..	Enroll..	FTES	Sectio..	Enroll..	FTES	Sectio..	Enroll..	FTES	Sectio..	Enroll..	FTES
Face to Face Course	180	4,413	570	888	22,687	3,245	941	22,716	3,214	200	4,441	564	943	22,904	3,260	984	22,200	3,364
Online Course	105	4,042	409	181	5,925	608	200	6,653	655	106	3,727	380	198	6,249	640	225	6,784	685
Grand Total	285	8,455	978	1,069	28,612	3,852	1,141	29,369	3,868	306	8,168	944	1,141	29,153	3,900	1,209	28,984	4,048



Retention & Success for all AHC

course_type	Summer 2013	Fall 2013	Spring 2014	Summer 2014	Fall 2014	Spring 2015	Measure Names
Face to Face Course	85%	84%	74%	65%	74%	75%	Retention %
Online Course	70%	80%	78%	89%	81%	79%	Success %
Grand Total	77%	84%	80%	74%	70%	77%	

Retention & Success MT

course_type	course	Summer 2013	Fall 2013	Spring 2014	Summer 2014	Fall 2014	Spring 2015	Retention %	Success %
Face to Face Course	MT109	89%	76%	85%	92%	80%	73%	100%	82%
	MT110			74%		84%	69%		69%
	MT111					89%	80%		80%
	MT112						86%		86%
	MT113						76%		85%
	MT115						90%		100%
	MT117						75%		100%
	MT179A						75%		100%
	MT300								100%
	MT311			70%					75%
	MT313			67%					65%
	MT314		98%						92%
	MT330		92%		91%				100%
	MT379G				94%				100%
	MT381		100%	100%	100%				100%
	MT389						100%		100%
		<b>Total</b>	<b>89%</b>	<b>82%</b>	<b>79%</b>	<b>92%</b>	<b>78%</b>	<b>80%</b>	<b>100%</b>
Online Course	MT301					50%			50%
	<b>Total</b>					<b>50%</b>			<b>50%</b>
<b>Grand Total</b>		<b>86%</b>	<b>82%</b>	<b>79%</b>	<b>92%</b>	<b>75%</b>	<b>80%</b>	<b>100%</b>	<b>87%</b>

Scheduling Viz Data - Fall 2014 MT

subj_crse_no	CRN	Site Code	FTEF/FTEF	FTEF	FTEF	Enrollment	Max Enroll	Fill Rate	Day 1 Waitlist	Demand Ratio
MT 109	21927	SM	11.46	5.57	0.49	20.00	20.00	100%	7.00	135%
MT 110	22980	SM	10.89	5.29	0.49	19.00	18.00	106%	0.00	106%
MT 111	22982	SM	10.23	3.85	0.38	18.00	18.00	100%	0.00	100%
MT 117	23398	SM		1.07	0.00	10.00	25.00	40%	0.00	40%
MT 300	23402	SM	4.27	0.85	0.20	8.00	35.00	23%	0.00	23%
MT 301	23447	ON	7.79	1.04	0.13	16.00	24.00	67%	0.00	67%

Scheduling Viz - Fall 2014 MT

Term Code - Desc  
Fall 2014

Subject Code  
MT

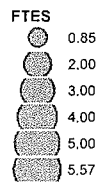

Totals for Selections

FTES/FTEF	10.51
FTES	17.67
FTEF	1.68
Fill Rate	65%
Sections	6
Avg Class Size	15
Day 1 Waitlist	7

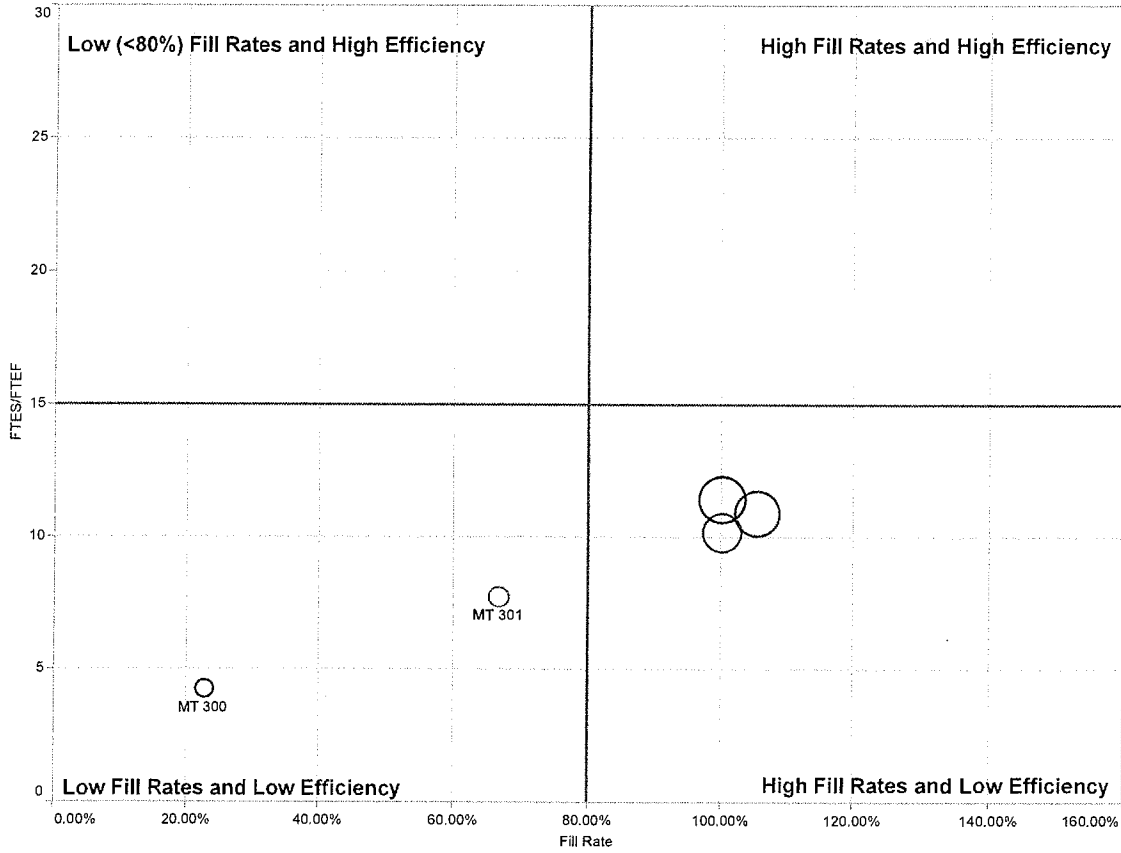

subj_crse_no	CRN	Site Code	FTES/FTEF	FTES	FTEF	Enrollment	Max Enroll	Fill Rate	Day 1 Waitlist	Demand Ratio
MT 109	21927	SM	11.46	5.57	0.49	20.00	20.00	100%	7.00	135%
MT 110	22980	SM	10.89	5.29	0.49	19.00	18.00	106%	0.00	106%
MT 111	22982	SM	10.23	3.85	0.38	18.00	18.00	100%	0.00	100%
MT 117	23398	SM		1.07	0.00	10.00	25.00	40%	0.00	40%

Scheduling Viz Data - Spring 2015 MT

subj_crse_no	CRN	Site Code	FTEF/FTEF	FTEF	FTEF	Enrollment	Max Enroll	Fill Rate	Day 1 Waitlist	Demand Ratio
MT 109	40328	SM	12.61	6.13	0.49	22.00	20.00	110%	2.00	120%
MT 110	41936	SM	7.45	3.62	0.49	13.00	20.00	65%	0.00	65%
MT 112	41937	SM	8.53	3.21	0.38	15.00	20.00	75%	0.00	75%
MT 113	41940	SM	13.36	2.67	0.20	25.00	25.00	100%	1.00	104%
MT 115	41938	SM	11.22	2.24	0.20	21.00	24.00	88%	0.00	88%
MT 117	41872	SM		0.75	0.00	7.00	25.00	28%	0.00	28%
MT 179A	42105	SM	9.21	1.11	0.12	17.00	18.00	94%	0.00	94%
MT 300	41866	SM	3.74	0.75	0.20	7.00	25.00	28%	1.00	32%

Scheduling Viz - Spring 2015 MT

Term Code - Desc  
Spring 2015

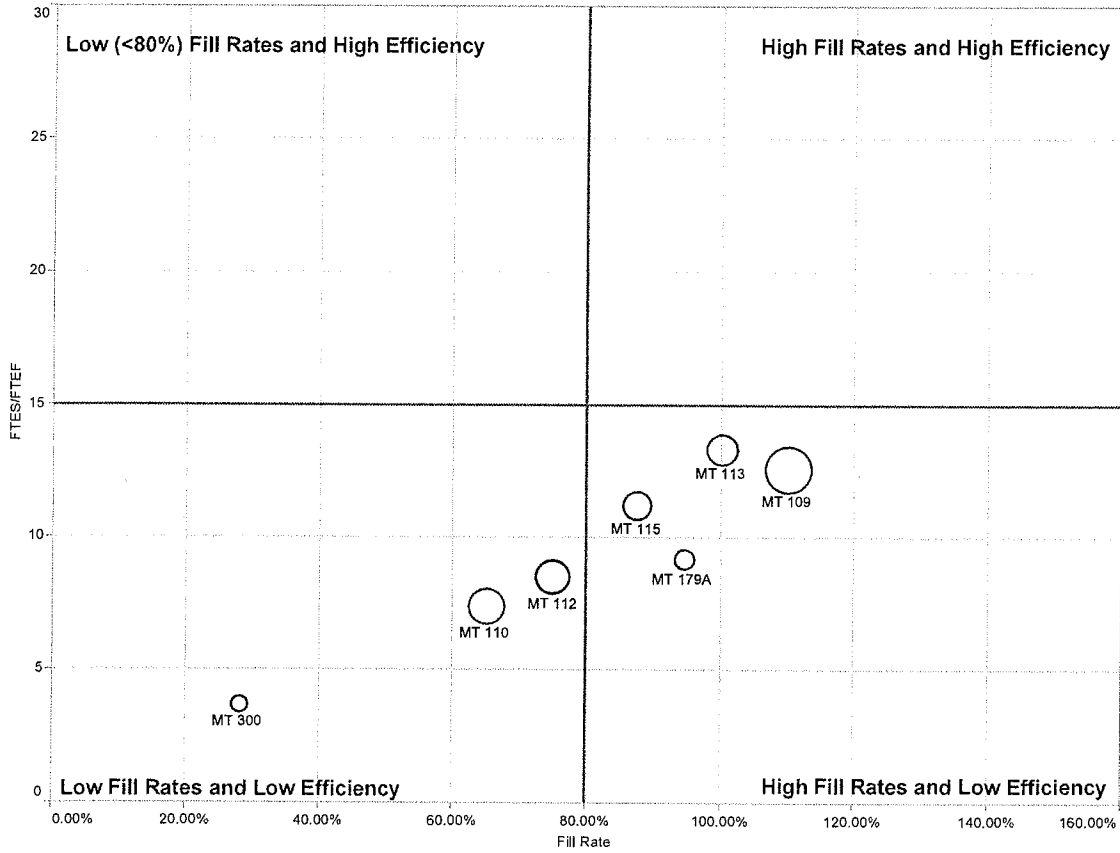

Subject Code  
MT

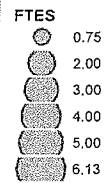

Totals for Selections

FTES/FTEF	9.90
FTES	20.48
FTEF	2.07
Fill Rate	72%
Sections	8
Avg Class Size	16
Day 1 Waitlist	4

subj_crse_no	CRN	Site Code	FTES/FTEF	FTES	FTEF	Enrollment	Max Enroll	Fill Rate	Day 1 Waitlist	Demand Ratio
MT 109	40328	SM	12.61	6.13	0.49	22.00	20.00	110%	2.00	120%
MT 110	41936	SM	7.45	3.62	0.49	13.00	20.00	65%	0.00	65%
MT 112	41937	SM	8.53	3.21	0.38	15.00	20.00	75%	0.00	75%
MT 113	41940	SM	13.36	2.67	0.20	25.00	25.00	100%	1.00	104%

Degrees & Certificates

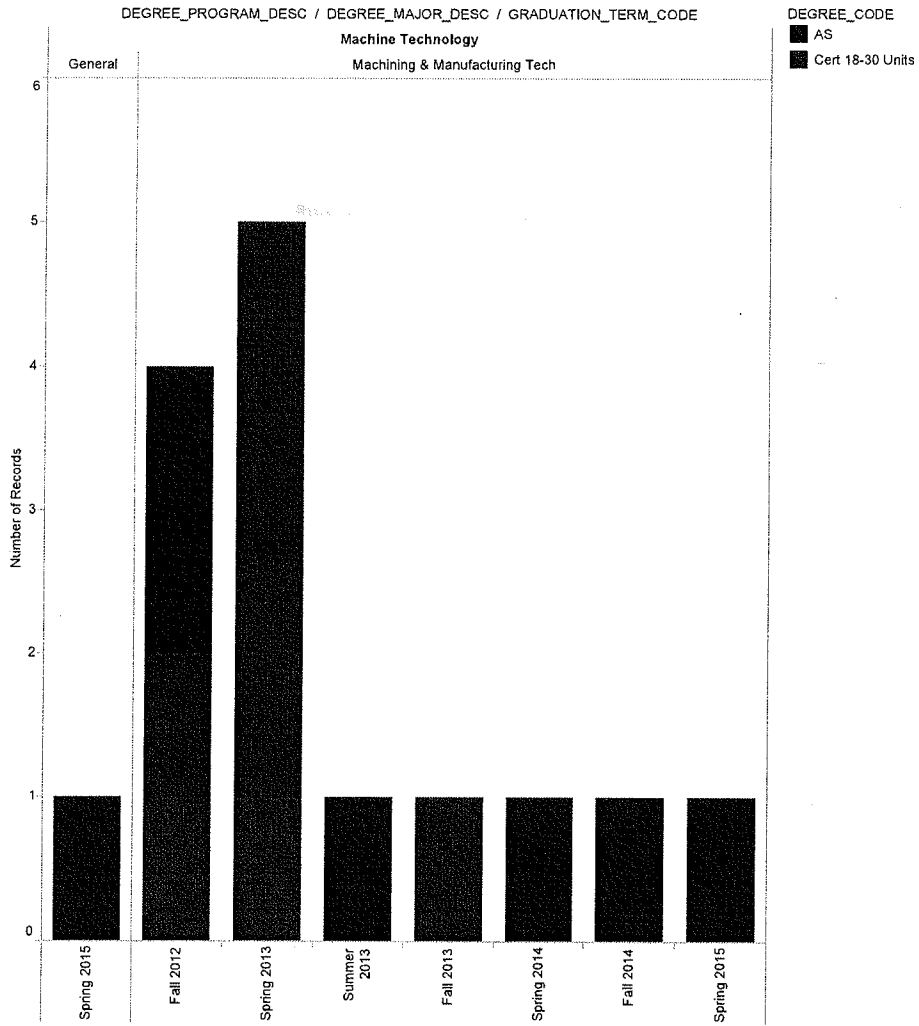

All data provided within was gathered from publically available Tableau Reports. To get more information or investigate the data further you can access Tableau by going to myHancock -> Work Tools/Faculty tab -> Assessment & IRP channel -> Tableau link.

For any further questions you can contact Armando Cortez at [Armando.Cortez@hancockcollege.edu](mailto:Armando.Cortez@hancockcollege.edu).



# Appendix C - MT Student Learning Outcomes

### MT Student Learning Outcomes Assessment Plan

Course	Student Learning Outcome	Assessment
MT 109	Survey of Machining and Mfg.	
	SLO1 - Use standard inside/outside micrometers and dial calipers.	Fall 2015
	SLO2 - Select and set various stationary and rotating cutting tools.	Fall 2015
	SLO3 - Calculate feeds and speeds	Summer 2015
	SLO4 - Perform basic manipulative skills utilizing the drill press, band saw, pedestal grinder...	Spring 2016
	SLO5 - Work in a machine facility in a safe manner.	Summer 2016
MT 110	CNC Principles and Practices 1	
	SLO1 - Identify the parts, functions, and capabilities of a horizontal mill CNC milling machin...	Spring 2016
	SLO2 - Perform intermediate manipulative skills (include calculating feeds and speeds.)	Spring 2017
	SLO3 - Identify, select, and properly use various kinds of hand tools utilized in the machinin...	Spring 2018
	SLO4 - Function in the machining facility in a productive and safe manner.	Spring 2019
MT 111	CNC Principles and Practices 2	
	SLO1 - Select and set appropriate CNC machines and cutting tools.	Fall 2015
	SLO2 - Select and set CNC work offsets, tool offsets and cutter compensation.	Fall 2016
	SLO3 - Troubleshoot CNC programs.	Fall 2017
	SLO4 - Create advanced CNC part programs using Mastercam (CAD/CAM) software.	Fall 2018
	SLO5 - Work in a CNC machining facility in a safe and productive manner.	Fall 2019
MT 112	CNC Principles and Practices 3	
	SLO1 - Create 2D geometry and 3D models using Mastercam.	Spring 2016
	SLO2 - Create roughing and finishing toolpaths for a variety of complex surfaces.	Spring 2017
	SLO3 - Create toolpaths and manufacture products on 4 axis CNC milling machines and CNC lathes...	Spring 2018
	SLO4 - Create toolpaths and manufacture products on 5 axis CNC milling machines.	Spring 2019
MT 113	SolidWorks 1	
	SLO1 - Create a solid model using SolidWorks.	Spring 2016
	SLO2 - Create a simple assembly using created models.	Spring 2017
	SLO3 - Create and dimension an orthographic projection from a solid model.	Spring 2018

	SLO4 - Attempt the Certified SolidWorks Associate (CSWA) assessment.	Spring 2019
MT 114	SolidWorks 2	
	SLO1 - Create complex three dimensional models using SolidWorks.	TBD
	SLO2 - Create complex assemblies using SolidWorks.	TBD
	SLO3 - Evaluate assembly motion using software simulation.	TBD
	SLO4 - Perform basic stress analysis on solid models.	TBD
MT 115	Lean Manufacturing	
	SLO1 - Recognize sources of operational waste and inefficiency.	Spring 2016
	SLO2 - Identify the cultural changes required to sustain improvement.	Spring 2017
	SLO3 - Define value from the perspective of the customer and differentiate value adding from non-value adding activities.	Spring 2018
	SLO4 - Employ Lean Tools to determine appropriate countermeasures for identified sources of waste.	Spring 2019
	SLO5 - Determine the requirements to meet the goal of providing value to the customer.	Spring 2016
	SLO6 - Identify the cultural changes required to sustain improvement.	Spring 2017
MT 116	Mastercam	
	SLO1- Create part programs for CNC machines and cutting tools using Mastercam.	Summer 2015
	SLO2 - Include CNC work offsets, tool offsets and cutter compensation in CNC programs.	Summer 2016
	SLO3 - Troubleshoot CAD files and CNC programs.	Summer 2017
	SLO4 - Generate text files to operate a variety of CNC machine tools.	Summer 2018
MT 117	Print Reading and Interpretation	
	SLO1 - Read and interpret various engineering drawings by completing numerous assignments.	Fall 2015
	SLO2 - Identify surface finish marks, tolerance, basic architecture, and welding symbols and be able to explain their meanings.	Spring 2016
	SLO3 - Use an engineering drawing accompanying specifications and materials lists to solve industrial questions, to complete ...	Fall 2016
	SLO4 - Use related handbooks, codes, and other references as they may be needed to solve a print reading question.	Spring 2017
MT 118	Understanding and Measuring GD&T	
	SLO1 - Describe symbols used in GD&T.	TBD
	SLO2 - Understand how symbols relate to features of a part.	TBD

	SLO3 - Choose the appropriate instrument and technique to measure a given feature.	TBD
	SLO4 - Apply material conditions in GD&T.	TBD
	SLO5 - Use simple functional gages to check parts.	TBD
	SLO6 - Measure using a coordinate measuring machine (CMM).	TBD
MT 300		
	SLO1 - Solve problems dealing with fractions, percentage, ratio.	Fall 2015
	SLO2 - Understand and interpret decimal numbers and fractions.	Spring 2016
	SLO3 - Select the correct method for solving an applied problem using mathematics.	Fall 2016
	SLO4 - Define the properties of basic geometric shapes.	Spring 2017
	SLO5 - Identify locations using the Cartesian coordinate system.	Fall 2017
	SLO6 - Use a variety of basic and precision measuring tools.	Spring 2018
MT 301	Introduction to Safety	
	SLO1 - Work Safely and Productively in an Industrial Workplace.	Fall 2015
	SLO2 - Perform safety and environmental inspections.	Fall 2016
	SLO3 - Identify unsafe conditions and take corrective action.	Fall 2017
	SLO4 - Suggest processes and procedures that support safety of work environment.	Fall 2018
MT 302	Quality & Process Improvement	
	SLO1 - Identify fundamentals of blueprint reading.	TBD
	SLO2 - Use common measurement systems and precision measurement tools.	TBD
	SLO3 - Inspect materials and product/process to ensure they meet specifications.	TBD
	SLO4 - Suggest process improvements.	TBD
MT 303	Manufacturing Processes and Production	
	SLO1 - Identify customer needs.	TBD
	SLO2 - Determine resources available for the production process.	TBD
	SLO3 - Set up equipment for the production process.	TBD
	SLO4 - Communicate production and material requirements and product specifications.	TBD
MT 304	Maintenance Awareness	
	SLO1 - Perform preventive maintenance and routine repair.	TBD
	SLO2 - Monitor indicators to ensure correct operations.	TBD
	SLO3 - Perform all housekeeping to maintain production schedule.	TBD
	SLO4 - Recognize potential maintenance issues with basic production systems.	TBD

MT 370	SkillsUSA	
	SLO1 - Gather data, research, evaluate, and use appropriate information to plan and complete a multi-faceted project.	Fall 2017
	SLO2 - Enlist community support for educational projects.	Fall 2018
	SLO3 - Assume responsibility for meeting deadlines, maintaining budgets and completing projects.	Fall 2019
	SLO4 - Evaluate contest preparations for completeness, clarity, and presentation.	Fall 2020

# Course Statistics And Evidence

Machine Technology

Date: 12/01/2015

Terms Fall 2015, Summer 2015, Spring 2015, Fall 2014, Summer 2014, Spring 2014, Fall 2013, Summer 2013, Spring 2013, Fall 2012, Summer 2012, Spring 2012, Fall 2011, Summer 2011, Spring 2011, Fall 2010

## Summary

Statistic	Count	Courses/Contexts
Courses	16	MT109, MT110, MT111, MT112, MT113, MT115, MT116, MT117, MT118, MT179A, MT300, MT301, MT302, MT313, MT379G, MT389
Courses with CSLOs	14	MT109, MT110, MT111, MT112, MT115, MT116, MT117, MT118, MT300, MT301, MT302, MT313, MT379G, MT389
Courses without CSLOs	2	MT113, MT179A
Courses with CSLOs mapped to PSLOs	11	MT109, MT110, MT111, MT112, MT115, MT117, MT300, MT301, MT313, MT379G, MT389
Courses without CSLOs mapped to PSLOs	5	MT113, MT116, MT118, MT179A, MT302
Courses with directly assessed PSLOs	0	
Courses with CSLOs mapped to ILOs	9	MT109, MT110, MT111, MT117, MT300, MT301, MT313, MT379G, MT389
Courses without CSLOs mapped to ILOs	7	MT112, MT113, MT115, MT116, MT118, MT179A, MT302
Courses with directly assessed ILOs	0	
Courses with Assessments	7	MT109, MT110, MT111, MT112, MT300, MT313, MT379G
Courses with all Assessments scored	6	MT109, MT379G, MT110, MT111, MT313, MT112
Courses with some Assessments scored	1	MT300
Courses without any Assessment scored	0	
Courses without Assessments	9	MT113, MT115, MT116, MT117, MT118, MT179A, MT301, MT302, MT389
Courses with Action Plans	15	MT109, MT110, MT111, MT112, MT113, MT115, MT117, MT118, MT179A, MT300, MT301, MT302, MT313, MT379G, MT389
Courses with all Action Plans answered	0	
Courses with some Action Plans answered	7	MT109, MT379G, MT110, MT111, MT313, MT300, MT112
Courses without any Action Plan answered	8	MT301, MT389, MT117, MT118, MT115, MT302, MT113, MT179A
Courses without Action Plans	1	MT116

MT109 - Survey of Machining and Mfg.

### SLOs

CSLOs	<ul style="list-style-type: none"> <li>» MT109 SLO1 - Use standard inside/outside micrometers and dial calipers.</li> <li>» MT109 SLO2 - Select and set various stationary and rotating cutting tools.</li> <li>» MT109 SLO3 - Calculate feeds and speeds.</li> <li>» MT109 SLO4 - Perform basic manipulative skills utilizing the drill press, band saw, pedestal grinders and various hand tools.</li> <li>» MT109 SLO5 - Work in a machine facility in a safe manner.</li> </ul>
Mapped PSLOs	<ul style="list-style-type: none"> <li>» MT PSLO3 - Possess essential academic skills in reading, writing, math, using and locating information and basic computer competency.</li> <li>» MT PSLO5 - Understand the basics of safety, quality assurance and continuous improvement, or lean manufacturing.</li> <li>» MT PSLO6 - Function effectively in a manufacturing environment containing a variety of production, welding, machining and metal-forming or CNC equipment.</li> </ul>

Mapped ILOs	» ILO 4B - Technology Literacy: Proficiency in a technology and the ability to choose the appropriate tools. » ILO 7 - Personal Responsibility & Development: Take the initiative and responsibility to assess your own actions with regard to physical wellness, learning opportunities, career planning, creative contribution to the community and ethical integrity in the home, workplace and community.
-------------	--

**Assessments**

Fall 2012

Homework Section #2 Question #7

SLO	Scored	Institutional Exceeds Standards	Institutional Meets Standards	Institutional Below Standards	N/A
MT109 SLO3 - Calculate feeds and speeds.	11 of 26	63.64%	27.27%	9.09%	2

Safety Test Part 3

SLO	Scored	Institutional Exceeds Standards	Institutional Meets Standards	Institutional Below Standards	N/A
MT109 SLO5 - Work in a machine facility in a safe manner.	11 of 26	63.64%	27.27%	9.09%	3

Spring 2013

Select Various Cutting Tools

SLO	Scored	Institutional Exceeds Standards	Institutional Meets Standards	Institutional Below Standards	N/A
MT109 SLO2 - Select and set various stationary and rotating cutting tools.	20 of 40	15%	35%	50%	0

Summer 2013

Milling project (Box)

SLO	Scored	Institutional Exceeds Standards	Institutional Meets Standards	Institutional Below Standards	N/A
MT109 SLO1 - Use standard inside/outside micrometers and dial calipers.	17 of 19	64.71%	35.29%	0%	2
MT109 SLO2 - Select and set various stationary and rotating cutting tools.	17 of 19	70.59%	29.41%	0%	2
MT109 SLO3 - Calculate feeds and speeds.	17 of 19	70.59%	29.41%	0%	2
MT109 SLO5 - Work in a machine facility in a safe manner.	17 of 19	70.59%	23.53%	5.88%	2

Fall 2013

Homework Section #2 Question #7

SLO	Scored	Institutional Exceeds Standards	Institutional Meets Standards	Institutional Below Standards	N/A
MT109 SLO3 - Calculate feeds and speeds.	15 of 35	33.33%	46.67%	20%	0

Select and set various tools

SLO	Scored	Institutional Exceeds Standards	Institutional Meets Standards	Institutional Below Standards	N/A
MT109 SLO2 - Select and set various stationary and rotating cutting tools.	20 of 35	0%	65%	35%	0

Spring 2014

Homework Section #2 Question #7

SLO	Scored	Institutional Exceeds Standards	Institutional Meets Standards	Institutional Below Standards	N/A
MT109 SLO3 - Calculate feeds and speeds.	16 of 34	31.25%	50%	18.75%	0

Summer 2014

Milling project (Box)

SLO	Scored	Institutional Exceeds Standards	Institutional Meets Standards	Institutional Below Standards	N/A
MT109 SLO1 - Use standard inside/outside micrometers and dial calipers.	15 of 17	33.33%	66.67%	0%	2
MT109 SLO2 - Select and set various stationary and rotating cutting tools.	15 of 17	33.33%	66.67%	0%	2
MT109 SLO3 - Calculate feeds and speeds.	15 of 17	33.33%	66.67%	0%	2
MT109 SLO5 - Work in a machine facility in a safe manner.	15 of 17	93.33%	6.67%	0%	2

Fall 2014

SLO	Scored	Institutional Exceeds Standards	Institutional Meets Standards	Institutional Below Standards	N/A
MT109 SLO1 - Use standard inside/outside micrometers and dial calipers.	18 of 18	55.56%	33.33%	11.11%	0
MT109 SLO2 - Select and set various stationary and rotating cutting tools.	18 of 18	55.56%	33.33%	11.11%	0
MT109 SLO3 - Calculate feeds and speeds.	18 of 18	55.56%	33.33%	11.11%	0
MT109 SLO4 - Perform basic manipulative skills utilizing the drill press, band saw, pedestal grinders and various hand tools.	17 of 18	52.94%	35.29%	11.76%	0
MT109 SLO5 - Work in a machine facility in a safe manner.	18 of 18	55.56%	33.33%	11.11%	0

**Action Plans**

Fall 2012

Course Improvement Plan Machine Technology Fall 2012

Expected Action	Action Type	Respondent	Action Taken	Date	Resource Request
Allan Hancock College >> Machine Technology >> MT109 - Fall 2012					
What did the assessment data indicate about the strengths of your course?		Anonymous	Most students met or exceeded expectations. No changes needed.	2012-12-14	
What did the assessment data indicate about the weaknesses of your course?		Anonymous	Assignments or learning directives require specific tuning	2012-12-14	
What changes have you made/do you plan to make based on the data? What resources would you need, if any, to make these changes?		Anonymous	Update program data with revised text books, update machinery (manual lathes and mills, drill press), providing students with a variety of modern operational equipment.	2012-12-14	

Fall 2014

Course Improvement Plan Machine Technology Fall 2014

Expected Action	Action Type	Respondent	Action Taken	Date	Resource Request
Allan Hancock College >> Machine Technology >> MT109 - Fall 2014					
What did the assessment data indicate about the strengths of your course?		Anonymous	Attendance was up for this class. few student found this class mentally and physically challenging	2014-12-18	
What did the assessment data indicate about the weaknesses of your course?		Anonymous	First semester in a new classroom and lab. Finding materials and tooling for the students working on machinery took too long. Not enough machine for the size of class (ratio machine to students too low)	2014-12-18	
What changes have you made/do you plan to make based on the data? What resources would you need, if any, to make these changes?		Anonymous	Inquired for additional machines to be purchased (Manual Mill & Lathes) and Additional instructor (paid) lab hours for organization of the new lab environment.	2014-12-18	

**MT110 - CNC Principles and Practices 1**

SLOs	
CSLOs	<ul style="list-style-type: none"> <li>» MT110 SLO1 - Identify the parts, functions, and capabilities of a horizontal mill CNC milling machine, lathe, band saw machines, tool grinders, and drill grinders.</li> <li>» MT110 SLO2 - Perform intermediate manipulative skills (include calculating feeds and speeds.)</li> <li>» MT110 SLO3 - Identify, select, and properly use various kinds of hand tools utilized in the machining industry, including enhanced layout tools and procedures.</li> <li>» MT110 SLO4 - Function in the machining facility in a productive and safe manner.</li> </ul>
Mapped PSLOs	<ul style="list-style-type: none"> <li>» MT PSLO1 - Understand the importance of attendance and punctuality.</li> <li>» MT PSLO3 - Possess essential academic skills in reading, writing, math, using and locating information and basic computer competency.</li> <li>» MT PSLO5 - Understand the basics of safety, quality assurance and continuous improvement, or lean manufacturing.</li> <li>» MT PSLO6 - Function effectively in a manufacturing environment containing a variety of production, welding, machining and metal-forming or CNC equipment.</li> </ul>
Mapped ILOs	<ul style="list-style-type: none"> <li>» ILO 4B - Technology Literacy: Proficiency in a technology and the ability to choose the appropriate tools.</li> <li>» ILO 7 - Personal Responsibility &amp; Development: Take the initiative and responsibility to assess your own actions with regard to physical wellness, learning opportunities, career planning, creative contribution to the community and ethical integrity in the home, workplace and community.</li> </ul>



Spring 2013

Function Productively in a Machine Shop

SLO	Scored	Institutional Exceeds Standards	Institutional Meets Standards	Institutional Below Standards	N/A
MT110 SLO4 - Function in the machining facility in a productive and safe manner.	25 of 25	52%	44%	4%	0

Fall 2014

Perform intermediate manipulative skills

SLO	Scored	Institutional Exceeds Standards	Institutional Meets Standards	Institutional Below Standards	N/A
MT110 SLO2 - Perform intermediate manipulative skills (include calculating feeds and speeds.)	16 of 16	0%	100%	0%	0

Spring 2015

Final Practicum

SLO	Scored	Institutional Exceeds Standards	Institutional Meets Standards	Institutional Below Standards	N/A
MT110 SLO2 - Perform intermediate manipulative skills (include calculating feeds and speeds.)	8 of 9	0%	87.5%	12.5%	1
MT110 SLO4 - Function in the machining facility in a productive and safe manner.	8 of 9	0%	100%	0%	1

Action Plans

None complete for this course

MT111 - CNC Principles and Practices 2

SLOs

CSLOs	<ul style="list-style-type: none"> <li>» MT111 SLO1 - Select and set appropriate CNC machines and cutting tools.</li> <li>» MT111 SLO2 - Select and set CNC work offsets, tool offsets and cutter compensation.</li> <li>» MT111 SLO3 - Troubleshoot CNC programs.</li> <li>» MT111 SLO4 - Create advanced CNC part programs using Mastercam (CAD/CAM) software.</li> <li>» MT111 SLO5 - Work in a CNC machining facility in a safe and productive manner.</li> </ul>
Mapped PSLOs	<ul style="list-style-type: none"> <li>» MT PSLO1 - Understand the importance of attendance and punctuality.</li> <li>» MT PSLO3 - Possess essential academic skills in reading, writing, math, using and locating information and basic computer competency.</li> <li>» MT PSLO6 - Function effectively in a manufacturing environment containing a variety of production, welding, machining and metal-forming or CNC equipment.</li> </ul>
Mapped ILOs	<ul style="list-style-type: none"> <li>» ILO 4B - Technology Literacy: Proficiency in a technology and the ability to choose the appropriate tools.</li> <li>» ILO 7 - Personal Responsibility &amp; Development: Take the initiative and responsibility to assess your own actions with regard to physical wellness, learning opportunities, career planning, creative contribution to the community and ethical integrity in the home, workplace and community.</li> </ul>

Assessments

Fall 2012

Create Programs Using Mastercam

SLO	Scored	Institutional Exceeds Standards	Institutional Meets Standards	Institutional Below Standards	N/A
MT111 SLO4 - Create advanced CNC part programs using Mastercam (CAD/CAM) software.	20 of 21	45%	25%	30%	2

Fall 2014

set CNC work offsets, tool offsets

SLO	Scored	Institutional Exceeds Standards	Institutional Meets Standards	Institutional Below Standards	N/A
MT111 SLO2 - Select and set CNC work offsets, tool offsets and cutter compensation.	18 of 18	0%	72.22%	27.78%	0

## Action Plans

Fall 2012

Course Improvement Plan Machine Technology Fall 2012

Expected Action	Action Type	Respondent	Action Taken	Date	Resource Request
Allan Hancock College >> Machine Technology >> MT111 - Fall 2012					
What did the assessment data indicate about the strengths of your course?		Anonymous	Students with CNC experience were better prepared to succeed.	2012-12-14	
What did the assessment data indicate about the weaknesses of your course?		Anonymous	Students without CNC experience should be encouraged to take MT 110 CNC Principles 1 before this course.	2012-12-14	
What changes have you made/do you plan to make based on the data? What resources would you need, if any, to make these changes?		Anonymous	Revise catalog description.	2012-12-14	

Fall 2014

Course Improvement Plan Machine Technology Fall 2014

Expected Action	Action Type	Respondent	Action Taken	Date	Resource Request
Allan Hancock College >> Machine Technology >> MT111 - Fall 2014					
What did the assessment data indicate about the strengths of your course?		Anonymous	72.2% are meeting the standard.	2015-02-09	
What did the assessment data indicate about the weaknesses of your course?		Anonymous	Some students were unable to set CNC work offsets, tool offsets	2015-02-09	
What changes have you made/do you plan to make based on the data? What resources would you need, if any, to make these changes?		Anonymous	More attention will be paid to these settings	2015-02-09	

### MT112 - CNC Principles and Practices 3

SLOs	
CSLOs	<ul style="list-style-type: none"> <li>» MT112 SLO1 - Create 2D geometry and 3D models using Mastercam.</li> <li>» MT112 SLO2 - Create roughing and finishing toolpaths for a variety of complex surfaces.</li> <li>» MT112 SLO3 - Create toolpaths and manufacture products on 4 axis CNC milling machines and CNC lathes with live tooling.</li> <li>» MT112 SLO4 - Create toolpaths and manufacture products on 5 axis CNC milling machines.</li> </ul>
Mapped PSLOs	<ul style="list-style-type: none"> <li>» MT PSLO3 - Possess essential academic skills in reading, writing, math, using and locating information and basic computer competency.</li> <li>» MT PSLO6 - Function effectively in a manufacturing environment containing a variety of production, welding, machining and metal-forming or CNC equipment.</li> <li>» MT100 SLO7 - Possess a variety of basic and high-tech skills consistent with modern manufacturing processes.</li> </ul>
Mapped ILOs	» (None)

### Assessments

Spring 2015

Final Exam Practicum

SLO	Scored	Institutional Exceeds Standards	Institutional Meets Standards	Institutional Below Standards	N/A
MT112 SLO2 - Create roughing and finishing toolpaths for a variety of complex surfaces.	12 of 12	25%	66.67%	8.33%	0
MT112 SLO3 - Create toolpaths and manufacture products on 4 axis CNC milling machines and CNC lathes with live tooling.	12 of 12	25%	66.67%	8.33%	0

### Action Plans

None complete for this course

### MT113 - SolidWorks 1

SLOs	
CSLOs	» (None)
Mapped PSLOs	» (None)
Mapped ILOs	» (None)

### Action Plans

None complete for this course

**MT115 - Lean Manufacturing**

<b>SLOs</b>	
CSLOs	<ul style="list-style-type: none"> <li>» MT115 SLO1 - Identify continuous improvement strategies.</li> <li>» MT115 SLO2 - Describe data gathering and statistical testing.</li> <li>» MT115 SLO3 - Recognize production bottlenecks.</li> <li>» MT115 SLO4 - Explain Lean Manufacturing.</li> </ul>
Mapped PSLOs	<ul style="list-style-type: none"> <li>» MT PSLO2 - Have experience working in collaboration with others.</li> <li>» MT PSLO3 - Possess essential academic skills in reading, writing, math, using and locating information and basic computer competency.</li> <li>» MT PSLO5 - Understand the basics of safety, quality assurance and continuous improvement, or lean manufacturing.</li> <li>» MT100 SLO7 - Possess a variety of basic and high-tech skills consistent with modern manufacturing processes.</li> </ul>
Mapped ILOs	» (None)

**Action Plans**

*None complete for this course*

**MT116 - Mastercam**

<b>SLOs</b>	
CSLOs	<ul style="list-style-type: none"> <li>» MT116 SLO1 - Create part programs for CNC machines and cutting tools using Mastercam.</li> <li>» MT116 SLO2 - Include CNC work offsets, tool offsets and cutter compensation in CNC programs.</li> <li>» MT116 SLO3 - Troubleshoot CAD files and CNC programs.</li> <li>» MT116 SLO4 - Generate text files to operate a variety of CNC machine tools.</li> </ul>
Mapped PSLOs	» (None)
Mapped ILOs	» (None)

**MT117 - Print Reading & Interpretation**

<b>SLOs</b>	
CSLOs	<ul style="list-style-type: none"> <li>» MT117 SLO1 - Read and interpret various engineering drawings by completing numerous assignments.</li> <li>» MT117 SLO2 - Identify surface finish marks, tolerance, basic architecture, and welding symbols and be able to explain their meanings.</li> <li>» MT117 SLO3 - Use an engineering drawing accompanying specifications and materials lists to solve industrial questions, to complete a project, or solve a related problem.</li> <li>» MT117 SLO4 - Use related handbooks, codes, and other references as they may be needed to solve a print reading question.</li> <li>» MT117 SLO5 - Be able to read engineering drawings which have multi-views and auxiliary views. Understand multi-view projection. Obtain the skills to read drawings that include section views. Read working/assembly drawings.</li> <li>» MT117 SLO6 - Ability to read and interpret drawing with fasteners &amp; weld symbols. Be able to read prints with cam, gear, &amp; bearings details.</li> <li>» MT117 SLO7 - Ability to read and interpret General dimensioning and tolerancing as well as geometric dimensioning and tolerancing.</li> </ul>
Mapped PSLOs	<ul style="list-style-type: none"> <li>» ET DRAFTING PSLO - Develop the ability to use engineering handbooks, ordinances, codes and incorporate such regulations with engineering design and production decisions.</li> <li>» ET DRAFTING PSLO - Develop the ability to read engineering drawings and specifications.</li> <li>» ET GENERAL PSLO - Develop familiarity with the principles and application of engineering drawing, including, freehand sketching, pictorial drawings, engineering lettering, dimensioning, sections, auxiliary, surface finish, standard and geometric tolerancing, threads, and fasteners.</li> <li>» ET DRAFTING PSLO - Develop the ability to understand the intent of the engineer by interpreting the relationship of the two-dimensional drawings with respect to the actual objects or projects.</li> </ul>
Mapped ILOs	<ul style="list-style-type: none"> <li>» ILO 4A - Information Literacy: Define what information is needed to solve a real-life issue and locate, access, evaluate and manage the information.</li> <li>» ILO 2 - Critical Thinking &amp; Problem Solving: Explore issues through various information sources; evaluate the credibility and significance of both the information and the source to arrive at a reasoned conclusion.</li> </ul>

**Action Plans**

*None complete for this course*

**MT118 - Understanding & Measuring GD&T**

<b>SLOs</b>	
CSLOs	<ul style="list-style-type: none"> <li>» MT118 SLO1 - Describe symbols used in GD&amp;T.</li> <li>» MT118 SLO2 - Understand how symbols relate to features of a part.</li> <li>» MT118 SLO3 - Choose the appropriate instrument and technique to measure a given feature.</li> <li>» MT118 SLO4 - Apply material conditions in GD&amp;T.</li> <li>» MT118 SLO5 - Use simple functional gauges to check parts.</li> <li>» MT118 SLO6 - Measure using a coordinate measuring machine (CMM).</li> </ul>

Mapped PSLOs	» (None)
Mapped ILOs	» (None)

**Action Plans**

*None complete for this course*

**MT179A - Machining Fundamentals 1**

**SLOs**

CSLOs	» (None)
Mapped PSLOs	» (None)
Mapped ILOs	» (None)

**Action Plans**

*None complete for this course*

**MT300 - Shop Math and Measurement**

**SLOs**

CSLOs	<ul style="list-style-type: none"> <li>» MT300 SLO1 - Solve problems dealing with fractions, percentage, ratio.</li> <li>» MT300 SLO2 - Understand and interpret decimal numbers and fractions.</li> <li>» MT300 SLO3 - Select the correct method for solving an applied problem using mathematics.</li> <li>» MT300 SLO4 - Define the properties of basic geometric shapes.</li> <li>» MT300 SLO5 - Identify locations using the Cartesian coordinate system.</li> <li>» MT300 SLO6 - Use a variety of basic and precision measuring tools.</li> </ul>
Mapped PSLOs	<ul style="list-style-type: none"> <li>» MT PSLO3 - Possess essential academic skills in reading, writing, math, using and locating information and basic computer competency.</li> <li>» MT PSLO6 - Function effectively in a manufacturing environment containing a variety of production, welding, machining and metal-forming or CNC equipment.</li> <li>» MT PSLO7 - Possess a variety of basic and high-tech skills consistent with modern manufacturing processes.</li> </ul>
Mapped ILOs	<ul style="list-style-type: none"> <li>» ILO 4A - Information Literacy: Define what information is needed to solve a real-life issue and locate, access, evaluate and manage the information.</li> <li>» ILO 2 - Critical Thinking &amp; Problem Solving: Explore issues through various information sources; evaluate the credibility and significance of both the information and the source to arrive at a reasoned conclusion.</li> <li>» ILO 5 - Quantitative Literacy: Use mathematical concepts and models to analyze and solve real life issues or problems.</li> </ul>

**Assessments**

*Fall 2014*

Cartesian Coordinates

SLO	Scored	Institutional Exceeds Standards	Institutional Meets Standards	Institutional Below Standards	N/A
MT300 SLO5 - Identify locations using the Cartesian coordinate system.	6 of 6	0%	100%	0%	0

*Spring 2015*

Final Exam SLO 1&6

SLO	Scored	Institutional Exceeds Standards	Institutional Meets Standards	Institutional Below Standards	N/A
MT300 SLO1 - Solve problems dealing with fractions, percentage, ratio.	7 of 7	14.29%	71.43%	14.29%	0
MT300 SLO6 - Use a variety of basic and precision measuring tools.	7 of 7	14.29%	71.43%	14.29%	0

**Action Plans**

*None complete for this course*

**MT301 - Introduction to Safety**

**SLOs**

CSLOs	<ul style="list-style-type: none"> <li>» MT301 SLO1 - Work safely and productively in an industrial workplace.</li> <li>» MT301 SLO2 - Perform safety and environmental inspections.</li> <li>» MT301 SLO3 - Identify unsafe conditions and take corrective action.</li> <li>» MT301 SLO4 - Suggest processes and procedures that support safety of work environment.</li> </ul>
Mapped PSLOs	<ul style="list-style-type: none"> <li>» MT PSLO2 - Have experience working in collaboration with others.</li> <li>» MT PSLO4 - Communicate effectively and interpret key instructions.</li> <li>» MT PSLO5 - Understand the basics of safety, quality assurance and continuous improvement, or lean manufacturing.</li> <li>» MT PSLO6 - Function effectively in a manufacturing environment containing a variety of production, welding, machining and metal-forming or CNC equipment.</li> </ul>

Mapped ILOs	<ul style="list-style-type: none"> <li>» ILO 1 - Communication: Communicate effectively using verbal, visual and written language with clarity and purpose in workplace, community and academic contexts.</li> <li>» ILO 4A - Information Literacy: Define what information is needed to solve a real-life issue and locate, access, evaluate and manage the information.</li> <li>» ILO 2 - Critical Thinking &amp; Problem Solving: Explore issues through various information sources; evaluate the credibility and significance of both the information and the source to arrive at a reasoned conclusion.</li> <li>» ILO 7 - Personal Responsibility &amp; Development: Take the initiative and responsibility to assess your own actions with regard to physical wellness, learning opportunities, career planning, creative contribution to the community and ethical integrity in the home, workplace and community.</li> </ul>
-------------	---

**Action Plans**  
None complete for this course

**MT302 - Quality & Process Improvement**

<b>SLOs</b>	
CSLOs	<ul style="list-style-type: none"> <li>» MT302 SLO1 - Identify fundamentals of blueprint reading.</li> <li>» MT302 SLO2 - Use common measurement systems and precision measurement tools.</li> <li>» MT302 SLO3 - Inspect materials and product/process to ensure they meet specifications.</li> <li>» MT302 SLO4 - Suggest process improvements.</li> </ul>
Mapped PSLOs	» (None)
Mapped ILOs	» (None)

**Action Plans**  
None complete for this course

**MT313 - SolidWorks 1**

<b>SLOs</b>	
CSLOs	<ul style="list-style-type: none"> <li>» MT313 SLO1 - Create a solid model using SolidWorks.</li> <li>» MT313 SLO2 - Create an assembly using created models.</li> <li>» MT313 SLO3 - Create and dimension and orthographic projection from a created model.</li> </ul>
Mapped PSLOs	<ul style="list-style-type: none"> <li>» MT PSLO6 - Function effectively in a manufacturing environment containing a variety of production, welding, machining and metal-forming or CNC equipment.</li> <li>» MT100 SLO7 - Possess a variety of basic and high-tech skills consistent with modern manufacturing processes.</li> </ul>
Mapped ILOs	<ul style="list-style-type: none"> <li>» ILO 4B - Technology Literacy: Proficiency in a technology and the ability to choose the appropriate tools.</li> <li>» ILO 5 - Quantitative Literacy: Use mathematical concepts and models to analyze and solve real life issues or problems.</li> </ul>

**Assessments**  
Spring 2013  
Mid term

SLO	Scored	Institutional Exceeds Standards	Institutional Meets Standards	Institutional Below Standards	N/A
MT313 SLO1 - Create a solid model using SolidWorks.	19 of 19	68.42%	26.32%	5.26%	0
MT313 SLO3 - Create and dimension and orthographic projection from a created model.	19 of 19	68.42%	26.32%	5.26%	0

**Action Plans**  
Spring 2013

Course Improvement Plan Machine Technology Spring 2013

Expected Action	Action Type	Respondent	Action Taken	Date	Resource Request
Allan Hancock College >> Machine Technology >> MT313 - Spring 2013					
What did the assessment data indicate about the strengths of your course?		Anonymous	In general, the course material presentation was adequate for meeting the slo's.	2013-05-28	
What did the assessment data indicate about the weaknesses of your course?		Anonymous	Although not compelling, the percentage of students with above average rubric hints that the course pace could be faster.	2013-05-28	
What changes have you made/do you plan to make based on the data? What resources would you need, if any, to make these changes?		Anonymous	Accelerate the pace of the these two slo's to bring in the third by 10 weeks of the semester and focus the balance of the semester on mastery.	2013-05-28	

**MT379G - MFG Operations & Logistics**

<b>SLOs</b>	
CSLOs	<ul style="list-style-type: none"> <li>» MT379G SLO1 - Recognize sources of operational waste and inefficiency.</li> <li>» MT379G SLO2 - Define value from the perspective of the customer and differentiate value adding from non-value adding activities.</li> <li>» MT379G SLO3 - Employ Lean Tools to determine appropriate countermeasures for identified sources of waste.</li> </ul>

	<ul style="list-style-type: none"> <li>» MT379G SLO4 - Focus on the goal of providing value to the customer and recognize the cultural changes required to sustain improvement models.</li> </ul>
Mapped PSLOs	<ul style="list-style-type: none"> <li>» MT PSLO2 - Have experience working in collaboration with others.</li> <li>» MT PSLO5 - Understand the basics of safety, quality assurance and continuous improvement, or lean manufacturing.</li> </ul>
Mapped ILOs	<ul style="list-style-type: none"> <li>» ILO 2 - Critical Thinking &amp; Problem Solving: Explore issues through various information sources; evaluate the credibility and significance of both the information and the source to arrive at a reasoned conclusion.</li> <li>» ILO 4B - Technology Literacy: Proficiency in a technology and the ability to choose the appropriate tools.</li> <li>» ILO 7 - Personal Responsibility &amp; Development: Take the initiative and responsibility to assess your own actions with regard to physical wellness, learning opportunities, career planning, creative contribution to the community and ethical integrity in the home, workplace and community.</li> </ul>

**Assessments**

Spring 2013

Recognize Waste

SLO	Scored	Institutional Exceeds Standards	Institutional Meets Standards	Institutional Below Standards	N/A
MT379G SLO1 - Recognize sources of operational waste and inefficiency.	20 of 20	15%	50%	35%	0

**Action Plans**

Spring 2013

Course Improvement Plan Machine Technology Spring 2013

Expected Action	Action Type	Respondent	Action Taken	Date	Resource Request
Allan Hancock College >> Machine Technology >> MT379G - Spring 2013					
What did the assessment data indicate about the strengths of your course?		Anonymous	That most students are now able to recognize waste	2014-07-14	
What did the assessment data indicate about the weaknesses of your course?		Anonymous	n/a	2014-07-14	
What changes have you made/do you plan to make based on the data? What resources would you need, if any, to make these changes?		Anonymous	n/a	2014-07-14	

**MT389 - Ind Projects in Machine Tech**

**SLOs**

CSLOs	<ul style="list-style-type: none"> <li>» MT389 SLO1 - Plan and submit for instructional approval an independent project.</li> <li>» MT389 SLO2 - Gather data, research, evaluate, and use appropriate information to complete contractual project.</li> <li>» MT389 SLO3 - Assume responsibility for meeting set deadlines, and completing project.</li> <li>» MT389 SLO4 - Evaluate project for completeness, clarity, and presentation.</li> </ul>
Mapped PSLOs	<ul style="list-style-type: none"> <li>» MT PSLO1 - Understand the importance of attendance and punctuality.</li> <li>» MT PSLO2 - Have experience working in collaboration with others.</li> <li>» MT PSLO3 - Possess essential academic skills in reading, writing, math, using and locating information and basic computer competency.</li> <li>» MT PSLO5 - Understand the basics of safety, quality assurance and continuous improvement, or lean manufacturing.</li> </ul>
Mapped ILOs	<ul style="list-style-type: none"> <li>» ILO 1 - Communication: Communicate effectively using verbal, visual and written language with clarity and purpose in workplace, community and academic contexts.</li> <li>» ILO 4A - Information Literacy: Define what information is needed to solve a real-life issue and locate, access, evaluate and manage the information.</li> <li>» ILO 5 - Quantitative Literacy: Use mathematical concepts and models to analyze and solve real life issues or problems.</li> <li>» ILO 7 - Personal Responsibility &amp; Development: Take the initiative and responsibility to assess your own actions with regard to physical wellness, learning opportunities, career planning, creative contribution to the community and ethical integrity in the home, workplace and community.</li> </ul>

**Action Plans**

None complete for this course

## ILO Summary Map by Course/Context

Selected SLOs: All ILOs

Course Group: Courses for Machine Technology

	ILO 1 - Communication	ILO 2 - Critical Thinking & Problem Solving	ILO 3 - Global Awareness & Cultural Competence	ILO 4 - Information & Technology Literacy		ILO 5 - Quantitative Literacy	ILO 6 - Scientific Literacy	ILO 7 - Personal Responsibility & Development
	ILO 1 - Communication: Communicate effectively using verbal, visual, and written language with clarity and purpose in workplace, community and academic contexts.	ILO 2 - Critical Thinking & Problem Solving: Explore issues through various information sources; evaluate the credibility and significance of both the information and the source to arrive at a reasoned conclusion.	ILO 3 - Global Awareness & Cultural Competence: Respectfully interact with individuals of diverse perspectives, beliefs and values, being mindful of the limitation of your own cultural framework.	ILO 4A - Information Literacy: Define what information is needed to solve a real-life issue and locate, access, evaluate and manage the information.	ILO 4B - Technology Literacy: Proficiency in a technology and the ability to choose the appropriate tools.	ILO 5 - Quantitative Literacy: Use mathematical concepts and models to analyze and solve real life issues or problems.	ILO 6 - Scientific Literacy: Use scientific knowledge and methodologies to assess potential solutions to real-life challenges.	ILO 7 - Personal Responsibility & Development: Take the initiative and responsibility to assess your own actions with regard to physical wellness, learning opportunities, career planning, creative contribution to the community and ethical integrity in the home, workplace and community.
<b>Courses</b>								
MT109								
MT109 SLO1 - Use standard inside/outside micrometers and dial calipers.					X			
MT109 SLO2 - Select and set various stationary and rotating cutting tools.								
MT109 SLO3 - Calculate feeds and speeds.								
MT109 SLO4 - Perform basic manipulative skills utilizing the drill press, band saw, pedestal grinders and various hand tools.								
MT109 SLO5 - Work in a machine facility in a safe manner.								X
MT110								
MT110 SLO1 - Identify the parts, functions, and capabilities of a horizontal mill, CNC milling machine, lathe, band saw machines, tool grinders and drill grinders.								
MT110 SLO2 - Perform intermediate manipulative skills (include calculating feeds and speeds.)								

	ILO 1 - Communication	ILO 2 - Critical Thinking & Problem Solving	ILO 3 - Global Awareness & Cultural Competence	ILO 4 - Information & Technology Literacy		ILO 5 - Quantitative Literacy	ILO 6 - Scientific Literacy	ILO 7 - Personal Responsibility & Development
	ILO 1 - Communication. Communicate effectively using verbal, visual and written language with clarity and purpose in workplace, community and academic contexts.	ILO 2 - Critical Thinking & Problem Solving. Explore issues through various information sources; evaluate the credibility and significance of both the information and the source to arrive at a reasoned conclusion.	ILO 3 - Global Awareness & Cultural Competence. Respectfully interact with individuals of diverse perspectives, beliefs and values, being mindful of the limitation of your own cultural framework.	ILO 4A - Information Literacy. Define what information is needed to solve a real-life issue and locate, access, evaluate and manage the information.	ILO 4B - Technology Literacy. Proficiency in a technology and the ability to choose the appropriate tools.	ILO 5 - Quantitative Literacy. Use mathematical concepts and models to analyze and solve real life issues or problems.	ILO 6 - Scientific Literacy. Use scientific knowledge and methodologies to assess potential solutions to real-life challenges.	ILO 7 - Personal Responsibility & Development. Take the initiative and responsibility to assess your own actions with regard to physical wellness, learning opportunities, career planning, creative contribution to the community and ethical integrity in the home, workplace and community.
<b>Courses</b>								
MT110 SLO3 - Identify, select, and properly use various kinds of hand tools utilized in the machining industry, including enhanced layout tools and procedures.					X			
MT110 SLO4 - Function in the machining facility in a productive and safe manner.								X
MT111								
MT111 SLO1 - Select and set appropriate CNC machines and cutting tools.								
MT111 SLO2 - Select and set CNC work offsets, tool offsets and cutter compensation.								
MT111 SLO3 - Troubleshoot CNC programs.								
MT111 SLO4 - Create advanced CNC part programs using Mastercam (CAD/CAM) software.					X			
MT111 SLO5 - Work in a CNC machining facility in a safe and productive manner.								X
MT112								
MT112 SLO1 - Create 2D geometry and 3D models using Mastercam.								
MT112 SLO2 - Create roughing and finishing toolpaths for a variety of complex surfaces.								



	ILO 1 - Communication	ILO 2 - Critical Thinking & Problem Solving	ILO 3 - Global Awareness & Cultural Competence	ILO 4 - Information & Technology Literacy		ILO 5 - Quantitative Literacy	ILO 6 - Scientific Literacy	ILO 7 - Personal Responsibility & Development
	ILO 1 - Communication: Communicate effectively using verbal, visual and written language with clarity and purpose in workplace, community and academic contexts.	ILO 2 - Critical Thinking & Problem Solving: Explore issues through various information sources; evaluate the credibility and significance of both the information and the source to arrive at a reasoned conclusion.	ILO 3 - Global Awareness & Cultural Competence: Respectfully interact with individuals of diverse perspectives, beliefs and values; being mindful of the limitation of your own cultural framework.	ILO 4A - Information Literacy: Define what information is needed to solve a real-life issue and locate, access, evaluate and manage the information.	ILO 4B - Technology Literacy: Proficiency in a technology and the ability to choose the appropriate tools.	ILO 5 - Quantitative Literacy: Use mathematical concepts and models to analyze and solve real life issues or problems.	ILO 6 - Scientific Literacy: Use scientific knowledge and methodologies to assess potential solutions to real-life challenges.	ILO 7 - Personal Responsibility & Development: Take the initiative and responsibility to assess your own actions with regard to physical wellness, learning opportunities, career planning, creative contribution to the community and ethical integrity in the home, workplace and community.
<b>Courses</b>								
MT112 SLO3 - Create toolpaths and manufacture products on 4 axis CNC milling machines and CNC lathes with live tooling.								
MT112 SLO4 - Create toolpaths and manufacture products on 5 axis CNC milling machines.								
MT113								
MT115								
MT115 SLO1 - Identify continuous improvement strategies.								
MT115 SLO2 - Describe data gathering and statistical testing.								
MT115 SLO3 - Recognize production bottlenecks.								
MT115 SLO4 - Explain Lean Manufacturing.								
MT116								
MT116 SLO1 - Create part programs for CNC machines and cutting tools using Mastercam.								
MT116 SLO2 - Include CNC work offsets, tool offsets and cutter compensation in CNC programs.								
MT116 SLO3 - Troubleshoot CAD files and CNC programs.								

	ILO 1 - Communication	ILO 2 - Critical Thinking & Problem Solving	ILO 3 - Global Awareness & Cultural Competence	ILO 4 - Information & Technology Literacy		ILO 5 - Quantitative Literacy	ILO 6 - Scientific Literacy	ILO 7 - Personal Responsibility & Development
	ILO 1 - Communication: Communicate effectively using verbal, visual and written language with clarity and purpose in workplace, community and academic contexts.	ILO 2 - Critical Thinking & Problem Solving: Explore issues through various information sources; evaluate the credibility and significance of both the information and the source to arrive at a reasoned conclusion.	ILO 3 - Global Awareness & Cultural Competence: Respectfully interact with individuals of diverse perspectives, beliefs and values, being mindful of the limitation of your own cultural framework.	ILO 4A - Information Literacy: Define what information is needed to solve a real-life issue and locate, access, evaluate and manage the information.	ILO 4B - Technology Literacy: Proficiency in a technology and the ability to choose the appropriate tools.	ILO 5 - Quantitative Literacy: Use mathematical concepts and models to analyze and solve real life issues or problems.	ILO 6 - Scientific Literacy: Use scientific knowledge and methodologies to assess potential solutions to real-life challenges.	ILO 7 - Personal Responsibility & Development: Take the initiative and responsibility to assess your own actions with regard to physical wellness, learning opportunities, career planning, creative contribution to the community and ethical integrity in the home, workplace and community.
<b>Courses</b>								
MT116 SLO4 - Generate text files to operate a variety of CNC machine tools.								
MT117								
MT117 SLO1 - Read and interpret various engineering drawings by completing numerous assignments.				X				
MT117 SLO2 - Identify surface finish marks, tolerance, basic architecture, and welding symbols and be able to explain their meanings.				X				
MT117 SLO3 - Use an engineering drawing accompanying specifications and materials lists to solve industrial questions, to complete a project, or solve a related problem.		X						
MT117 SLO4 - Use related handbooks, codes, and other references as they may be needed to solve a print reading question.				X				
MT117 SLO5 - Be able to read engineering drawings which have multi-views and auxiliary views. Understand multi-view projection. Obtain the skills to read drawings that include section views. Read working/assembly drawings.				X				

	ILO 1 - Communication	ILO 2 - Critical Thinking & Problem Solving	ILO 3 - Global Awareness & Cultural Competence	ILO 4 - Information & Technology Literacy		ILO 5 - Quantitative Literacy	ILO 6 - Scientific Literacy	ILO 7 - Personal Responsibility & Development
	ILO 1 - Communication: Communicate effectively using verbal, visual and written language with clarity and purpose in workplace, community and academic contexts.	ILO 2 - Critical Thinking & Problem Solving: Explore issues through various information sources; evaluate the credibility and significance of both the information and the source to arrive at a reasoned conclusion.	ILO 3 - Global Awareness & Cultural Competence: Respectfully interact with individuals of diverse perspectives, beliefs and values being mindful of the limitation of your own cultural framework.	ILO 4A - Information Literacy: Define what information is needed to solve a real-life issue and locate, access, evaluate and manage the information.	ILO 4B - Technology Literacy: Proficiency in a technology and the ability to choose the appropriate tools.	ILO 5 - Quantitative Literacy: Use mathematical concepts and models to analyze and solve real-life issues or problems.	ILO 6 - Scientific Literacy: Use scientific knowledge and methodologies to assess potential solutions to real-life challenges.	ILO 7 - Personal Responsibility & Development: Take the initiative and responsibility to assess your own actions with regard to physical wellness, learning opportunities, career planning, creative contribution to the community and ethical integrity in the home, workplace and community.
<b>Courses</b>								
MT117 SLO6 - Ability to read and interpret drawing with fasteners & weld symbols. Be able to read prints with cam, gear, & bearings details.				X				
MT117 SLO7 - Ability to read and interpret General dimensioning and tolerancing as well as geometric dimensioning and tolerancing.				X				
MT118								
MT118 SLO1 - Describe symbols used in GD&T.								
MT118 SLO2 - Understand how symbols relate to features of a part.								
MT118 SLO3 - Choose the appropriate instrument and technique to measure a given feature.								
MT118 SLO4 - Apply material conditions in GD&T.								
MT118 SLO5 - Use simple functional gauges to check parts.								
MT118 SLO6 - Measure using a coordinate measuring machine (CMM).								
MT179A								
MT300								
MT300 SLO1 - Solve problems dealing with fractions, percentage, ratio.		X						

	ILO 1 - Communication	ILO 2 - Critical Thinking & Problem Solving	ILO 3 - Global Awareness & Cultural Competence	ILO 4 - Information & Technology Literacy		ILO 5 - Quantitative Literacy	ILO 6 - Scientific Literacy	ILO 7 - Personal Responsibility & Development
	ILO 1 - Communication: Communicate effectively using verbal, visual and written language with clarity and purpose in workplace, community and academic contexts.	ILO 2 - Critical Thinking & Problem Solving: Explore issues through various information sources; evaluate the credibility and significance of both the information and the source to arrive at a reasoned conclusion.	ILO 3 - Global Awareness & Cultural Competence: Respectfully interact with individuals of diverse perspectives, beliefs and values being mindful of the limitation of your own cultural framework.	ILO 4A - Information Literacy: Define what information is needed to solve a real-life issue and locate, access, evaluate and manage the information.	ILO 4B - Technology Literacy: Proficiency in a technology and the ability to choose the appropriate tools.	ILO 5 - Quantitative Literacy: Use mathematical concepts and models to analyze and solve real life issues or problems.	ILO 6 - Scientific Literacy: Use scientific knowledge and methodologies to assess potential solutions to real-life challenges.	ILO 7 - Personal Responsibility & Development: Take the initiative and responsibility to assess your own actions with regard to physical wellness, learning opportunities, career planning, creative contribution to the community and ethical integrity in the home, workplace and community.
<b>Courses</b>								
MT300 SLO2 - Understand and interpret decimal numbers and fractions.				X				
MT300 SLO3 - Select the correct method for solving an applied problem using mathematics.		X						
MT300 SLO4 - Define the properties of basic geometric shapes.						X		
MT300 SLO5 - Identify locations using the Cartesian coordinate system.						X		
MT300 SLO6 - Use a variety of basic and precision measuring tools.						X		
<b>MT301</b>								
MT301 SLO1 - Work safely and productively in an industrial workplace.								X
MT301 SLO2 - Perform safety and environmental inspections.				X				
MT301 SLO3 - Identify unsafe conditions and take corrective action.		X						
MT301 SLO4 - Suggest processes and procedures that support safety of work environment.	X							
MT302								

	ILO 1 - Communication	ILO 2 - Critical Thinking & Problem Solving	ILO 3 - Global Awareness & Cultural Competence	ILO 4 - Information & Technology Literacy		ILO 5 - Quantitative Literacy	ILO 6 - Scientific Literacy	ILO 7 - Personal Responsibility & Development
	ILO 1 - Communication: Communicate effectively using verbal, visual and written language with clarity and purpose in workplace, community and academic contexts.	ILO 2 - Critical Thinking & Problem Solving: Explore issues through various information sources; evaluate the credibility and significance of both the information and the source to arrive at a reasoned conclusion.	ILO 3 - Global Awareness & Cultural Competence: Respectfully interact with individuals of diverse perspectives, beliefs and values, being mindful of the limitation of your own cultural framework.	ILO 4A - Information Literacy: Define what information is needed to solve a real-life issue and locate, access, evaluate and manage the information.	ILO 4B - Technology Literacy: Proficiency in a technology and the ability to choose the appropriate tools.	ILO 5 - Quantitative Literacy: Use mathematical concepts and models to analyze and solve real life issues or problems.	ILO 6 - Scientific Literacy: Use scientific knowledge and methodologies to assess potential solutions to real-life challenges.	ILO 7 - Personal Responsibility & Development: Take the initiative and responsibility to assess your own actions with regard to physical wellness, learning opportunities, career planning, creative contribution to the community and ethical integrity in the home, workplace and community.
<b>Courses</b>								
MT302 SLO1 - Identify fundamentals of blueprint reading.								
MT302 SLO2 - Use common measurement systems and precision measurement tools.								
MT302 SLO3 - Inspect materials and product/process to ensure they meet specifications.								
MT302 SLO4 - Suggest process improvements.								
<b>MT313</b>								
MT313 SLO1 - Create a solid model using SolidWorks.					X			
MT313 SLO2 - Create an assembly using created models.					X			
MT313 SLO3 - Create and dimension and orthographic projection from a created model.						X		
<b>MT379G</b>								
MT379G SLO1 - Recognize sources of operational waste and inefficiency.		X						
MT379G SLO2 - Define value from the perspective of the customer and differentiate value adding from non-value adding activities.		X						

	ILO 1 - Communication	ILO 2 - Critical Thinking & Problem Solving	ILO 3 - Global Awareness & Cultural Competence	ILO 4 - Information & Technology Literacy		ILO 5 - Quantitative Literacy	ILO 6 - Scientific Literacy	ILO 7 - Personal Responsibility & Development
	ILO 1 - Communication: Communicate effectively using verbal, visual and written language with clarity and purpose in workplace, community and academic contexts.	ILO 2 - Critical Thinking & Problem Solving: Explore issues through various information sources; evaluate the credibility and significance of both the information and the source to arrive at a reasoned conclusion.	ILO 3 - Global Awareness & Cultural Competence: Respectfully interact with individuals of diverse perspectives, beliefs and values being mindful of the limitation of your own cultural framework.	ILO 4A - Information Literacy: Define what information is needed to solve a real-life issue and locate, access, evaluate and manage the information.	ILO 4B - Technology Literacy: Proficiency in a technology and the ability to choose the appropriate tools.	ILO 5 - Quantitative Literacy: Use mathematical concepts and models to analyze and solve real life issues or problems.	ILO 6 - Scientific Literacy: Use scientific knowledge and methodologies to assess potential solutions to real-life challenges.	ILO 7 - Personal Responsibility & Development: Take the initiative and responsibility to assess your own actions with regard to physical wellness, learning opportunities, career planning, creative contribution to the community and ethical integrity in the home, workplace and community.
<b>Courses</b>								
MT379G SLO3 - Employ Lean Tools to determine appropriate countermeasures for identified sources of waste					X			
MT379G SLO4 - Focus on the goal of providing value to the customer and recognize the cultural changes required to sustain improvement models.								X
MT389								
MT389 SLO1 - Plan and submit for instructional approval an independent project.	X							
MT389 SLO2 - Gather data, research, evaluate, and use appropriate information to complete contractual project.				X				
MT389 SLO3 - Assume responsibility for meeting set deadlines, and completing project.								X
MT389 SLO4 - Evaluate project for completeness, clarity, and presentation.						X		
	2	6	0	8	6	5	0	5

# SLO Performance - PSLO Overall

Program: Machine Technology

Date: 11/30/2015

## PSLO: MT PSLO1 - Understand the importance of attendance and punctuality.

	Institutional Exceeds Standards		Institutional Meets Standards		Institutional Below Standards		N/A		Total	
Spring 2015	0	0.00%	8	88.89%	0	0.00%	1	11.11%	9	100.00%
Spring 2013	13	52.00%	11	44.00%	1	4.00%	0	0.00%	25	100.00%
<b>Total</b>	<b>13</b>	<b>38.24%</b>	<b>19</b>	<b>55.88%</b>	<b>1</b>	<b>2.94%</b>	<b>1</b>	<b>2.94%</b>	<b>34</b>	<b>100.00%</b>

## PSLO: MT PSLO2 - Have experience working in collaboration with others.

	Institutional Exceeds Standards		Institutional Meets Standards		Institutional Below Standards		N/A		Total	
<b>Total</b>	<b>0</b>	<b>0.00%</b>	<b>0</b>	<b>0.00%</b>	<b>0</b>	<b>0.00%</b>	<b>0</b>	<b>0.00%</b>	<b>0</b>	<b>0.00%</b>

## PSLO: MT PSLO3 - Possess essential academic skills in reading, writing, math, using and locating information and basic computer competency.

	Institutional Exceeds Standards		Institutional Meets Standards		Institutional Below Standards		N/A		Total	
Spring 2015	1	6.25%	12	75.00%	2	12.50%	1	6.25%	16	100.00%
Fall 2014	10	29.41%	22	64.71%	2	5.88%	0	0.00%	34	100.00%
Summer 2014	5	29.41%	10	58.82%	0	0.00%	2	11.76%	17	100.00%
Summer 2013	11	57.89%	6	31.58%	0	0.00%	2	10.53%	19	100.00%
Fall 2012	9	40.91%	5	22.73%	6	27.27%	2	9.09%	22	100.00%
<b>Total</b>	<b>36</b>	<b>33.33%</b>	<b>55</b>	<b>50.93%</b>	<b>10</b>	<b>9.26%</b>	<b>7</b>	<b>6.48%</b>	<b>108</b>	<b>100.00%</b>

## PSLO: MT PSLO4 - Communicate effectively and interpret key instructions.

	Institutional Exceeds Standards		Institutional Meets Standards		Institutional Below Standards		N/A		Total	
<b>Total</b>	<b>0</b>	<b>0.00%</b>	<b>0</b>	<b>0.00%</b>	<b>0</b>	<b>0.00%</b>	<b>0</b>	<b>0.00%</b>	<b>0</b>	<b>0.00%</b>

## PSLO: MT PSLO5 - Understand the basics of safety, quality assurance and continuous improvement.

	Institutional Exceeds Standards		Institutional Meets Standards		Institutional Below Standards		N/A		Total	
Fall 2014	10	55.56%	6	33.33%	2	11.11%	0	0.00%	18	100.00%
Summer 2014	14	82.35%	1	5.88%	0	0.00%	2	11.76%	17	100.00%
Summer 2013	12	63.16%	4	21.05%	1	5.26%	2	10.53%	19	100.00%
Spring 2013	16	35.56%	21	46.67%	8	17.78%	0	0.00%	45	100.00%
Fall 2012	7	50.00%	3	21.43%	1	7.14%	3	21.43%	14	100.00%
<b>Total</b>	<b>59</b>	<b>48.36%</b>	<b>43</b>	<b>35.25%</b>	<b>12</b>	<b>9.84%</b>	<b>8</b>	<b>6.56%</b>	<b>122</b>	<b>100.00%</b>

## PSLO: MT PSLO6 - Function effectively in a manufacturing environment containing a variety of production, welding, machining and metal-forming or CNC equipment.

	Institutional Exceeds Standards		Institutional Meets Standards		Institutional Below Standards		N/A		Total	
Spring 2015	3	25.00%	8	66.67%	1	8.33%	0	0.00%	12	100.00%
Fall 2014	29	40.85%	31	43.66%	11	15.49%	0	0.00%	71	100.00%
Summer 2014	10	29.41%	20	58.82%	0	0.00%	4	11.76%	34	100.00%
Spring 2014	5	31.25%	8	50.00%	3	18.75%	0	0.00%	16	100.00%
Fall 2013	5	14.29%	20	57.14%	10	28.57%	0	0.00%	35	100.00%
Summer 2013	24	63.16%	10	26.32%	0	0.00%	4	10.53%	38	100.00%
Spring 2013	16	41.03%	12	30.77%	11	28.21%	0	0.00%	39	100.00%

Fall 2012	7	53.85%	3	23.08%	1	7.69%	2	15.38%	13	100.00%
<b>Total</b>	<b>99</b>	<b>38.37%</b>	<b>112</b>	<b>43.41%</b>	<b>37</b>	<b>14.34%</b>	<b>10</b>	<b>3.88%</b>	<b>258</b>	<b>100.00%</b>

**PSLO: MT100 SLO7 - Possess a variety of basic and high-tech skills consistent with modern manufacturing processes.**

	Institutional Exceeds Standards		Institutional Meets Standards		Institutional Below Standards		N/A		Total	
Spring 2015	4	21.05%	13	68.42%	2	10.53%	0	0.00%	19	100.00%
Spring 2013	13	68.42%	5	26.32%	1	5.26%	0	0.00%	19	100.00%
<b>Total</b>	<b>17</b>	<b>38.64%</b>	<b>24</b>	<b>54.55%</b>	<b>3</b>	<b>6.82%</b>	<b>0</b>	<b>0.00%</b>	<b>44</b>	<b>100.00%</b>

**Report Totals by Term:**

	Institutional Exceeds Standards		Institutional Meets Standards		Institutional Below Standards		N/A		Total	
Spring 2015	8	12.31%	49	75.38%	5	7.69%	3	4.62%	65	100.00%
Fall 2014	49	37.98%	65	50.39%	15	11.63%	0	0.00%	129	100.00%
Summer 2014	29	42.65%	31	45.59%	0	0.00%	8	11.76%	68	100.00%
Spring 2014	5	31.25%	8	50.00%	3	18.75%	0	0.00%	16	100.00%
Fall 2013	5	14.29%	20	57.14%	10	28.57%	0	0.00%	35	100.00%
Summer 2013	47	61.84%	20	26.32%	1	1.32%	8	10.53%	76	100.00%
Spring 2013	58	45.31%	49	38.28%	21	16.41%	0	0.00%	128	100.00%
Fall 2012	23	46.94%	11	22.45%	8	16.33%	7	14.29%	49	100.00%
<b>Total</b>	<b>224</b>	<b>39.56%</b>	<b>253</b>	<b>44.70%</b>	<b>63</b>	<b>11.13%</b>	<b>26</b>	<b>4.59%</b>	<b>566</b>	<b>100.00%</b>

**Grand Totals:**

	Institutional Exceeds Standards		Institutional Meets Standards		Institutional Below Standards		N/A		Total	
<b>Total</b>	<b>224</b>	<b>39.56%</b>	<b>253</b>	<b>44.70%</b>	<b>63</b>	<b>11.13%</b>	<b>26</b>	<b>4.59%</b>	<b>566</b>	<b>100.00%</b>



# PSLO Summary Map by Course/Context

Selected SLOs: PSLOs for Machine Technology

Course Group: Courses for Machine Technology

Courses	Machine Technology Program Outcomes						
	MT-PSLO1 - Understand the importance of attendance and punctuality	MT-PSLO2 - Have experience working in collaboration with others	MT-PSLO3 - Possess essential academic skills in reading, writing, math, using and locating information and basic computer competency	MT-PSLO4 - Communicate effectively and interpret key instructions	MT-PSLO5 - Understand the basics of safety, quality assurance and continuous improvement, or lean manufacturing	MT-PSLO6 - Function effectively in a manufacturing environment containing a variety of production, welding, machining and metal forming or CNC equipment	MT-100 SLO7 - Possess a variety of basic and high-tech skills consistent with modern manufacturing processes
<b>MT109</b>							
MT109 SLO1 - Use standard inside/outside micrometers and dial calipers			X				
MT109 SLO2 - Select and set various stationary and rotating cutting tools						X	
MT109 SLO3 - Calculate feeds and speeds						X	
MT109 SLO4 - Perform basic manipulative skills utilizing the drill press, band saw, pedestal grinders, and various hand tools						X	
MT109 SLO5 - Work in a machine facility in a safe manner					X		
<b>MT110</b>							
MT110 SLO1 - Identify the parts, functions, and capabilities of a horizontal mill, CNC milling machine, lathe, band saw machines, tool grinders, and drill grinders						X	
MT110 SLO2 - Perform intermediate manipulative skills (include calculating feeds and speeds.)			X				
MT110 SLO3 - Identify, select, and properly use various kinds of hand tools utilized in the machining industry, including enhanced layout tools and procedures						X	
MT110 SLO4 - Function in the machining facility in a productive and safe manner	X				X		
<b>MT111</b>							
MT111 SLO1 - Select and set appropriate CNC machines and cutting tools						X	

**Machine Technology Program Outcomes**

**Courses**

	MT PSLO1 - Understand the importance of attendance and punctuality	MT PSLO2 - Have experience working in collaboration with others	MT PSLO3 - Possess essential academic skills in reading, writing, math, using and locating information and basic computer competency	MT PSLO4 - Communicate effectively and interpret key instructions	MT PSLO5 - Understand the basics of safety, quality assurance and continuous improvement, or lean manufacturing	MT PSLO6 - Function effectively in a manufacturing environment containing a variety of production, welding, machining and metal-forming or CNC equipment	MT100 SLO7 - Possess a variety of basic and high-tech skills consistent with modern manufacturing processes
MT111 SLO2 - Select and set CNC work offsets, tool offsets and cutter compensation						X	
MT111 SLO3 - Troubleshoot CNC programs			X				
MT111 SLO4 - Create advanced CNC part programs using Mastercam (CAD/CAM) software			X				
MT111 SLO5 - Work in a CNC machining facility in a safe and productive manner	X						
<b>MT112</b>							
MT112 SLO1 - Create 2D geometry and 3D models using Mastercam			X				
MT112 SLO2 - Create roughing and finishing toolpaths for a variety of complex surfaces						X	
MT112 SLO3 - Create toolpaths and manufacture products on 4 axis CNC milling machines and CNC lathes with live tooling							X
MT112 SLO4 - Create toolpaths and manufacture products on 5 axis CNC milling machines							X
<b>MT113</b>							
<b>MT115</b>							
MT115 SLO1 - Identify continuous improvement strategies		X			X		
MT115 SLO2 - Describe data gathering and statistical testing			X				
MT115 SLO3 - Recognize production bottlenecks							X
MT115 SLO4 - Explain Lean Manufacturing					X		
<b>MT116</b>							
MT116 SLO1 - Create part programs for CNC machines and cutting tools using Mastercam							

**Machine Technology Program Outcomes**

**Courses**

	MT PSLO1 - Understand the importance of attendance and punctuality	MT PSLO2 - Have experience working in collaboration with others	MT PSLO3 - Possess essential academic skills in reading, writing, math, using and locating information and basic computer competency	MT PSLO4 - Communicate effectively and interpret key instructions	MT PSLO5 - Understand the basics of safety, quality assurance and continuous improvement, or lean manufacturing	MT PSLO6 - Function effectively in a manufacturing environment containing a variety of production, welding, machining and metal-forming or CNC equipment	MT100 SLO7 - Possess a variety of basic and high-tech skills consistent with modern manufacturing processes
MT116 SLO2 - Include CNC work offsets, tool offsets and cutter compensation in CNC programs.							
MT116 SLO3 - Troubleshoot CAD files and CNC programs.							
MT116 SLO4 - Generate text files to operate a variety of CNC machine tools							
<b>MT117</b>							
MT117 SLO1 - Read and interpret various engineering drawings by completing numerous assignments							
MT117 SLO2 - Identify surface finish marks, tolerance, basic architecture, and welding symbols and be able to explain their meanings.							
MT117 SLO3 - Use an engineering drawing accompanying specifications and materials lists to solve industrial questions, to complete a project, or solve a related problem.							
MT117 SLO4 - Use related handbooks, codes, and other references as they may be needed to solve a print reading question.							
MT117 SLO5 - Be able to read engineering drawings which have multi-views and auxiliary views. Understand multi-view projection. Obtain the skills to read drawings that include section views. Read working/assembly drawings							
MT117 SLO6 - Ability to read and interpret drawing with fasteners & weld symbols. Be able to read prints with cam, gear, & bearings details.							

**Machine Technology Program Outcomes**

**Courses**

	MT/PSLO1 - Understand the importance of attendance and punctuality.	MT/PSLO2 - Have experience working in collaboration with others.	MT/PSLO3 - Possess essential academic skills in reading, writing, math, using and locating information and basic computer competency.	MT/PSLO4 - Communicate effectively and interpret key instructions.	MT/PSLO5 - Understand the basics of safety, quality assurance and continuous improvement, or lean manufacturing.	MT/PSLO6 - Function effectively in a manufacturing environment containing a variety of production, welding, machining and metal-forming or CNC equipment.	MT/PSLO7 - Possess a variety of basic and high-tech skills consistent with modern manufacturing processes.
MT117 SLO7 - Ability to read and interpret General dimensioning and tolerancing as well as geometric dimensioning and tolerancing.							
<b>MT118</b>							
MT118 SLO1 - Describe symbols used in GD&T.							
MT118 SLO2 - Understand how symbols relate to features of a part.							
MT118 SLO3 - Choose the appropriate instrument and technique to measure a given feature.							
MT118 SLO4 - Apply material conditions in GD&T.							
MT118 SLO5 - Use simple functional gauges to check parts.							
MT118 SLO6 - Measure using a coordinate measuring machine (CMM).							
<b>MT179A</b>							
<b>MT300</b>							
MT300 SLO1 - Solve problems dealing with fractions, percentage, ratio.			X				
MT300 SLO2 - Understand and interpret decimal numbers and fractions.					X		
MT300 SLO3 - Select the correct method for solving an applied problem using mathematics.							X
MT300 SLO4 - Define the properties of basic geometric shapes.			X				
MT300 SLO5 - Identify locations using the Cartesian coordinate system.							X
MT300 SLO6 - Use a variety of basic and precision measuring tools.							X
<b>MT301</b>							
MT301 SLO1 - Work safely and productively in an industrial workplace.					X		

**Machine Technology Program Outcomes**

**Courses**

	MT-PSLO1 - Understand the importance of attendance and punctuality.	MT-PSLO2 - Have experience working in collaboration with others.	MT-PSLO3 - Possess essential academic skills in reading, writing, math, using and locating information and basic computer competency.	MT-PSLO4 - Communicate effectively and interpret key instructions.	MT-PSLO5 - Understand the basics of safety, quality assurance and continuous improvement, or lean manufacturing.	MT-PSLO6 - Function effectively in a manufacturing environment containing a variety of production, welding, machining and metal-forming or CNC equipment.	MT-100 SLO7 - Possess a variety of basic and high-tech skills consistent with modern manufacturing processes.
MT301 SLO2 - Perform safety and environmental inspections.		X					
MT301 SLO3 - Identify unsafe conditions and take corrective action.						X	
MT301 SLO4 - Suggest processes and procedures that support safety of work environment.				X			
<b>MT302</b>							
MT302 SLO1 - Identify fundamentals of blueprint reading.							
MT302 SLO2 - Use common measurement systems and precision measurement tools.							
MT302 SLO3 - Inspect materials and product/process to ensure they meet specifications.							
MT302 SLO4 - Suggest process improvements.							
<b>MT313</b>							
MT313 SLO1 - Create a solid model using SolidWorks.							X
MT313 SLO2 - Create an assembly using created models.							X
MT313 SLO3 - Create and dimension and orthographic projection from a created model.						X	
<b>MT379G</b>							
MT379G SLO1 - Recognize sources of operational waste and inefficiency.					X		
MT379G SLO2 - Define value from the perspective of the customer and differentiate value adding from non-value adding activities.					X		
MT379G SLO3 - Employ Lean Tools to determine appropriate countermeasures for identified sources of waste.					X		

**Machine Technology Program Outcomes**

**Courses**

	MT-PSLO1 - Understand the importance of attendance and punctuality.	MT-PSLO2 - Have experience working in collaboration with others.	MT-PSLO3 - Possess essential academic skills in reading, writing, math, using and locating information and basic computer competency.	MT-PSLO4 - Communicate effectively and interpret key instructions.	MT-PSLO5 - Understand the basics of safety, quality assurance and continuous improvement, or lean manufacturing.	MT-PSLO6 - Function effectively in a manufacturing environment containing a variety of production, welding, machining and metal-forming or CNC equipment.	MT-100/SLO7 - Possess a variety of basic and high-tech skills consistent with modern manufacturing processes.
MT379G SLO4 - Focus on the goal of providing value to the customer and recognize the cultural changes required to sustain improvement models.		X					
<b>MT389</b>							
MT389 SLO1 - Plan and submit for instructional approval an independent project.		X					
MT389 SLO2 - Gather data, research, evaluate, and use appropriate information to complete contractual project.			X				
MT389 SLO3 - Assume responsibility for meeting set deadlines, and completing project.	X						
MT389 SLO4 - Evaluate project for completeness, clarity, and presentation.					X		
	3	4	9	1	9	11	8

# SLO Performance - By Department, Course, CSLO

Program: Machine Technology

Date: 11/30/2015

Terms Fall 2015, Summer 2015, Spring 2015, Fall 2014, Summer 2014, Spring 2014, Fall 2013, Summer 2013, Spring 2013, Fall 2012, Summer 2012, Spring 2012, Fall 2011, Summer 2011, Spring 2011, Fall 2010

## MT109: Survey of Machining and Mfg.

MT109 SLO1 - Use standard inside/outside micrometers and dial calipers.

	Institutional Exceeds Standards		Institutional Meets Standards		Institutional Below Standards		Total	
Fall 2014	10	55.56%	6	33.33%	2	11.11%	18	100.00%
Summer 2014	5	33.33%	10	66.67%	0	0.00%	15	100.00%
Summer 2013	11	64.71%	6	35.29%	0	0.00%	17	100.00%
Totals	26	52.00%	22	44.00%	2	4.00%	50	100.00%

MT109 SLO2 - Select and set various stationary and rotating cutting tools.

	Institutional Exceeds Standards		Institutional Meets Standards		Institutional Below Standards		Total	
Fall 2014	10	55.56%	6	33.33%	2	11.11%	18	100.00%
Summer 2014	5	33.33%	10	66.67%	0	0.00%	15	100.00%
Summer 2013	12	70.59%	5	29.41%	0	0.00%	17	100.00%
Spring 2013	3	15.00%	7	35.00%	10	50.00%	20	100.00%
Totals	30	33.33%	41	45.56%	19	21.11%	90	100.00%

MT109 SLO3 - Calculate feeds and speeds.

	Institutional Exceeds Standards		Institutional Meets Standards		Institutional Below Standards		Total	
Fall 2014	10	55.56%	6	33.33%	2	11.11%	18	100.00%
Summer 2014	5	33.33%	10	66.67%	0	0.00%	15	100.00%
Spring 2014	5	31.25%	8	50.00%	3	18.75%	16	100.00%
Fall 2013	5	33.33%	7	46.67%	3	20.00%	15	100.00%
Summer 2013	12	70.59%	5	29.41%	0	0.00%	17	100.00%
Fall 2012	7	63.64%	3	27.27%	1	9.09%	11	100.00%
Totals	44	47.83%	39	42.39%	9	9.78%	92	100.00%

MT109 SLO4 - Perform basic manipulative skills utilizing the drill press, band saw, pedestal grinders and various hand tools.

	Institutional Exceeds Standards		Institutional Meets Standards		Institutional Below Standards		Total	
Fall 2014	9	52.94%	6	35.29%	2	11.76%	17	100.00%
Totals	9	52.94%	6	35.29%	2	11.76%	17	100.00%

MT109 SLO5 - Work in a machine facility in a safe manner.

	Institutional Exceeds Standards		Institutional Meets Standards		Institutional Below Standards		Total	
Fall 2014	10	55.56%	6	33.33%	2	11.11%	18	100.00%
Summer 2014	14	93.33%	1	6.67%	0	0.00%	15	100.00%
Summer 2013	12	70.59%	4	23.53%	1	5.88%	17	100.00%
Fall 2012	7	63.64%	3	27.27%	1	9.09%	11	100.00%
Totals	43	70.49%	14	22.95%	4	6.56%	61	100.00%

Totals for Cslos

	Institutional Exceeds Standards		Institutional Meets Standards		Institutional Below Standards		Total	
Fall 2014	49	55.06%	30	33.71%	10	11.24%	89	100.00%
Summer 2014	29	48.33%	31	51.67%	0	0.00%	60	100.00%
Spring 2014	5	31.25%	8	50.00%	3	18.75%	16	100.00%
Fall 2013	5	14.29%	20	57.14%	10	28.57%	35	100.00%
Summer 2013	47	69.12%	20	29.41%	1	1.47%	68	100.00%
Spring 2013	3	15.00%	7	35.00%	10	50.00%	20	100.00%
Fall 2012	14	63.64%	6	27.27%	2	9.09%	22	100.00%

Totals	152	49.03%	122	39.35%	36	11.61%	310	100.00%
--------	-----	--------	-----	--------	----	--------	-----	---------

### MT110: CNC Principles and Practices 1

MT110 SLO1 - Identify the parts, functions, and capabilities of a horizontal mill CNC milling machine, lathe, band saw machines, tool grinders, and drill grinders.

	Institutional Exceeds Standards		Institutional Meets Standards		Institutional Below Standards		Total	
Totals	0	0.00%	0	0.00%	0	0.00%	0	0.00%

MT110 SLO2 - Perform intermediate manipulative skills (include calculating feeds and speeds.)

	Institutional Exceeds Standards		Institutional Meets Standards		Institutional Below Standards		Total	
Spring 2015	0	0.00%	7	87.50%	1	12.50%	8	100.00%
Fall 2014	0	0.00%	16	100.00%	0	0.00%	16	100.00%
Totals	0	0.00%	23	95.83%	1	4.17%	24	100.00%

MT110 SLO3 - Identify, select, and properly use various kinds of hand tools utilized in the machining industry, including enhanced layout tools and procedures.

	Institutional Exceeds Standards		Institutional Meets Standards		Institutional Below Standards		Total	
Totals	0	0.00%	0	0.00%	0	0.00%	0	0.00%

MT110 SLO4 - Function in the machining facility in a productive and safe manner.

	Institutional Exceeds Standards		Institutional Meets Standards		Institutional Below Standards		Total	
Spring 2013	13	52.00%	11	44.00%	1	4.00%	25	100.00%
Totals	13	39.39%	19	57.58%	1	3.03%	33	100.00%

Totals for Cslos

	Institutional Exceeds Standards		Institutional Meets Standards		Institutional Below Standards		Total	
Spring 2015	0	0.00%	15	93.75%	1	6.25%	16	100.00%
Fall 2014	0	0.00%	16	100.00%	0	0.00%	16	100.00%
Spring 2013	13	52.00%	11	44.00%	1	4.00%	25	100.00%
Totals	13	22.81%	42	73.68%	2	3.51%	57	100.00%

### MT111: CNC Principles and Practices 2

MT111 SLO1 - Select and set appropriate CNC machines and cutting tools.

	Institutional Exceeds Standards		Institutional Meets Standards		Institutional Below Standards		Total	
Totals	0	0.00%	0	0.00%	0	0.00%	0	0.00%

MT111 SLO2 - Select and set CNC work offsets, tool offsets and cutter compensation.

	Institutional Exceeds Standards		Institutional Meets Standards		Institutional Below Standards		Total	
Fall 2014	0	0.00%	13	72.22%	5	27.78%	18	100.00%
Totals	0	0.00%	13	72.22%	5	27.78%	18	100.00%

MT111 SLO3 - Troubleshoot CNC programs.

	Institutional Exceeds Standards		Institutional Meets Standards		Institutional Below Standards		Total	
Totals	0	0.00%	0	0.00%	0	0.00%	0	0.00%

MT111 SLO4 - Create advanced CNC part programs using Mastercam (CAD/CAM) software.

	Institutional Exceeds Standards		Institutional Meets Standards		Institutional Below Standards		Total	
Fall 2012	9	45.00%	5	25.00%	6	30.00%	20	100.00%
Totals	9	45.00%	5	25.00%	6	30.00%	20	100.00%



MT111 SLO5 - Work in a CNC machining facility in a safe and productive manner.

	Institutional Exceeds Standards		Institutional Meets Standards		Institutional Below Standards		Total	
Totals	0	0.00%	0	0.00%	0	0.00%	0	0.00%

Totals for Cslos

	Institutional Exceeds Standards		Institutional Meets Standards		Institutional Below Standards		Total	
Fall 2014	0	0.00%	13	72.22%	5	27.78%	18	100.00%
Fall 2012	9	45.00%	5	25.00%	6	30.00%	20	100.00%
Totals	9	23.68%	18	47.37%	11	28.95%	38	100.00%

**MT112: CNC Principles and Practices 3**

MT112 SLO1 - Create 2D geometry and 3D models using Mastercam.

	Institutional Exceeds Standards		Institutional Meets Standards		Institutional Below Standards		Total	
Totals	0	0.00%	0	0.00%	0	0.00%	0	0.00%

MT112 SLO2 - Create roughing and finishing toolpaths for a variety of complex surfaces.

	Institutional Exceeds Standards		Institutional Meets Standards		Institutional Below Standards		Total	
Spring 2015	3	25.00%	8	66.67%	1	8.33%	12	100.00%
Totals	3	25.00%	8	66.67%	1	8.33%	12	100.00%

MT112 SLO3 - Create toolpaths and manufacture products on 4 axis CNC milling machines and CNC lathes with live tooling.

	Institutional Exceeds Standards		Institutional Meets Standards		Institutional Below Standards		Total	
Spring 2015	3	25.00%	8	66.67%	1	8.33%	12	100.00%
Totals	3	25.00%	8	66.67%	1	8.33%	12	100.00%

MT112 SLO4 - Create toolpaths and manufacture products on 5 axis CNC milling machines.

	Institutional Exceeds Standards		Institutional Meets Standards		Institutional Below Standards		Total	
Totals	0	0.00%	0	0.00%	0	0.00%	0	0.00%

Totals for Cslos

	Institutional Exceeds Standards		Institutional Meets Standards		Institutional Below Standards		Total	
Spring 2015	6	25.00%	16	66.67%	2	8.33%	24	100.00%
Totals	6	25.00%	16	66.67%	2	8.33%	24	100.00%

**MT300: Shop Math and Measurement**

MT300 SLO1 - Solve problems dealing with fractions, percentage, ratio.

	Institutional Exceeds Standards		Institutional Meets Standards		Institutional Below Standards		Total	
Spring 2015	1	14.29%	5	71.43%	1	14.29%	7	100.00%
Totals	1	14.29%	5	71.43%	1	14.29%	7	100.00%

MT300 SLO2 - Understand and interpret decimal numbers and fractions.

	Institutional Exceeds Standards		Institutional Meets Standards		Institutional Below Standards		Total	
Totals	0	0.00%	0	0.00%	0	0.00%	0	0.00%

MT300 SLO3 - Select the correct method for solving an applied problem using mathematics.

	Institutional Exceeds Standards		Institutional Meets Standards		Institutional Below Standards		Total	
Totals	0	0.00%	0	0.00%	0	0.00%	0	0.00%

MT300 SLO4 - Define the properties of basic geometric shapes.

	Institutional Exceeds Standards		Institutional Meets Standards		Institutional Below Standards		Total	
Totals	0	0.00%	0	0.00%	0	0.00%	0	0.00%

MT300 SLO5 - Identify locations using the Cartesian coordinate system.

	Institutional Exceeds Standards		Institutional Meets Standards		Institutional Below Standards		Total	
Fall 2014	0	0.00%	6	100.00%	0	0.00%	6	100.00%
Totals	0	0.00%	6	100.00%	0	0.00%	6	100.00%

MT300 SLO6 - Use a variety of basic and precision measuring tools.

	Institutional Exceeds Standards		Institutional Meets Standards		Institutional Below Standards		Total	
Spring 2015	1	14.29%	5	71.43%	1	14.29%	7	100.00%
Totals	1	14.29%	5	71.43%	1	14.29%	7	100.00%

Totals for Cslos

	Institutional Exceeds Standards		Institutional Meets Standards		Institutional Below Standards		Total	
Spring 2015	2	14.29%	10	71.43%	2	14.29%	14	100.00%
Totals	2	10.00%	16	80.00%	2	10.00%	20	100.00%

### MT313: SolidWorks 1

MT313 SLO1 - Create a solid model using SolidWorks.

	Institutional Exceeds Standards		Institutional Meets Standards		Institutional Below Standards		Total	
Spring 2013	13	68.42%	5	26.32%	1	5.26%	19	100.00%
Totals	13	68.42%	5	26.32%	1	5.26%	19	100.00%

MT313 SLO2 - Create an assembly using created models.

	Institutional Exceeds Standards		Institutional Meets Standards		Institutional Below Standards		Total	
Totals	0	0.00%	0	0.00%	0	0.00%	0	0.00%

MT313 SLO3 - Create and dimension and orthographic projection from a created model.

	Institutional Exceeds Standards		Institutional Meets Standards		Institutional Below Standards		Total	
Spring 2013	13	68.42%	5	26.32%	1	5.26%	19	100.00%
Totals	13	68.42%	5	26.32%	1	5.26%	19	100.00%

Totals for Cslos

	Institutional Exceeds Standards		Institutional Meets Standards		Institutional Below Standards		Total	
Spring 2013	26	68.42%	10	26.32%	2	5.26%	38	100.00%
Totals	26	68.42%	10	26.32%	2	5.26%	38	100.00%

### MT379G: MFG Operations & Logistics

MT379G SLO1 - Recognize sources of operational waste and inefficiency.

	Institutional Exceeds Standards		Institutional Meets Standards		Institutional Below Standards		Total	
Spring 2013	3	15.00%	10	50.00%	7	35.00%	20	100.00%
Totals	3	15.00%	10	50.00%	7	35.00%	20	100.00%

MT379G SLO2 - Define value from the perspective of the customer and differentiate value adding from non-value adding activities.

	Institutional Exceeds Standards		Institutional Meets Standards		Institutional Below Standards		Total	
Totals	0	0.00%	0	0.00%	0	0.00%	0	0.00%

MT379G SLO3 - Employ Lean Tools to determine appropriate countermeasures for identified sources of waste.

	Institutional Exceeds Standards		Institutional Meets Standards		Institutional Below Standards		Total	
	Count	Percentage	Count	Percentage	Count	Percentage	Count	Percentage
Totals	0	0.00%	0	0.00%	0	0.00%	0	0.00%

MT379G SLO4 - Focus on the goal of providing value to the customer and recognize the cultural changes required to sustain improvement models.

	Institutional Exceeds Standards		Institutional Meets Standards		Institutional Below Standards		Total	
	Count	Percentage	Count	Percentage	Count	Percentage	Count	Percentage
Totals	0	0.00%	0	0.00%	0	0.00%	0	0.00%

Totals for Cslos

	Institutional Exceeds Standards		Institutional Meets Standards		Institutional Below Standards		Total	
	Count	Percentage	Count	Percentage	Count	Percentage	Count	Percentage
Spring 2013	3	15.00%	10	50.00%	7	35.00%	20	100.00%
Totals	3	15.00%	10	50.00%	7	35.00%	20	100.00%

**Report Totals:**

	Institutional Exceeds Standards		Institutional Meets Standards		Institutional Below Standards		Total	
	Count	Percentage	Count	Percentage	Count	Percentage	Count	Percentage
Spring 2015	8	14.81%	41	75.93%	5	9.26%	54	100.00%
Fall 2014	49	37.98%	65	50.39%	15	11.63%	129	100.00%
Summer 2014	29	48.33%	31	51.67%	0	0.00%	60	100.00%
Spring 2014	5	31.25%	8	50.00%	3	18.75%	16	100.00%
Fall 2013	5	14.29%	20	57.14%	10	28.57%	35	100.00%
Summer 2013	47	69.12%	20	29.41%	1	1.47%	68	100.00%
Spring 2013	45	43.69%	38	36.89%	20	19.42%	103	100.00%
Fall 2012	23	54.76%	11	26.19%	8	19.05%	42	100.00%
Totals	211	41.62%	234	46.15%	62	12.23%	507	100.00%

# Appendix D – Outside Resources

### 3. Outside Resources

Memorandum of Understanding (MOU) between Allan Hancock College  
and Karl Storz Imaging

February 13, 2012

This Memorandum of Understanding (MOU) between Allan Hancock College (AHC) and Karl Storz Imaging (KSI) will go into effect on August 15, 2012 and remain in effect until May 31, 2015.

During the period that this MOU is in effect, Allan Hancock College (AHC) and Karl Storz Imaging (KSI) agree to the following:

- 1) AHC will hire a full time faculty member for the Machining and Manufacturing Technology program and offer at least five (5) classes in Machining and Manufacturing Technology during the Fall semester and at least five (5) classes in the Spring semester in each of the following school years, 2012-2013, 2013-2014 and 2014-2015.
- 2) KSI will provide AHC with \$5,000 in cash and supplies valued at \$5,000 on August 15, 2012 for the 2012-2013 school year, \$5,000 in cash and supplies valued at \$5,000 on August 15, 2013 for the 2013-2014 school year and \$5,000 in cash and supplies valued at \$5,000 on August 15, 2014 for the 2014-2015 school year.
- 3) If AHC or KSI fails to uphold the minimum requirements set forth in item 1 and/or 2 for any reason, then this MOU is no longer binding.
- 4) Nothing in this MOU is intended to or will be construed to limit or affect in any way the authority or legal responsibilities of AHC or KSI.
- 5) Nothing in this MOU may be construed to obligate the KSI or AHC to any current or future expenditure not specified in this MOU.
- 6) Specific activities that involve the transfer of money or property between KSI and AHC will require execution of the purchase order and invoicing process.
- 7) Nothing in this MOU is intended to, or will, be construed to restrict the KSI or AHC from participating in similar activities or arrangements with other public or private organizations or individuals.
- 8) All press releases and public statements issued by the KSI or AHC concerning or characterizing this MOU will be jointly reviewed and agreed to by delegated

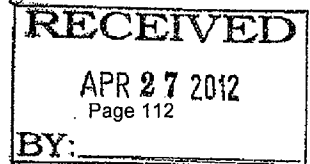

staff representing each of the undersigned signatories.

- 9) Periodic meetings by delegated staff representing each of the undersigned signatories will be scheduled to review progress and identify opportunities for advancing the purposes of this MOU.
- 10) KSI or AHC may terminate participation in this MOU no sooner than 90 days before any subsequent semester as designated by this MOU providing written notice to the other entity.
- 11) Only the KSI or AHC undersigned signatories may amend or modify this MOD through written and signed agreement.

This MOU will remain in effect provided that each party abides by the provisions of the MOU described above.

Dr. Jose M. Ortiz, Ed.D.  
Superintendent/President of Allan Hancock College

  
\_\_\_\_\_ Date 4.18.12

Emery Skarupa  
General Manager  
Karl Storz Imaging, Goleta, CA

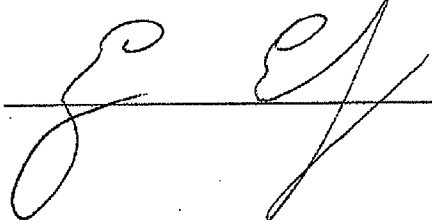
  
\_\_\_\_\_ Date 4/26/12



Memorandum of Understanding (MOU) between  
Allan Hancock College and Helical Products Company, Inc.

March 29, 2012

This Memorandum of Understanding (MOU) between Allan Hancock College and Helical Products Company, Inc. will go into effect on August 15, 2012 and remain in effect until May 31, 2015.

During the period that this MOU is in effect, Allan Hancock College and Helical Products Company, Inc. agree to the following:

- 1) Allan Hancock College will hire a full time faculty member for the Machining and Manufacturing Technology program and offer at least five (5) classes in Machining and Manufacturing Technology during the Fall semester and at least five (5) classes in the Spring semester in each of the following school years, 2012-2013, 2013-2014 and 2014-2015. During this three year period the classes offered will cover the full range of courses in the program. Classes will provide industry level instruction.
- 2) Helical Products Company, Inc. will provide Allan Hancock College Foundation with \$10,000 on August 15, 2012 for the 2012-2013 school year, \$10,000 on August 15, 2013 for the 2013-2014 school year, and \$10,000 on August 15, 2014 for the 2014-2015 school year.

This MOU will remain in effect provided that each party abides by the provisions of the MOU described above.

Dr. José M. Ortiz, Ed.D.  
Superintendent/President of Allan Hancock College

Date 4.18.12

Leroy McChesney  
Vice President of Operations, Helical Products Company, Inc., Santa Maria, CA

Date 3/29/2012



Memorandum of Understanding (MOU) between Allan Hancock College and Melfred Borzall, Inc.

April 16, 2012

This Memorandum of Understanding (MOU) between Allan Hancock College and Melfred Borzall, Inc. will go into effect on August 15, 2012 and remain in effect until May 31, 2015.

During the period that this MOU is in effect, Allan Hancock College and Melfred Borzall, Inc. agree to the following:

- 1) Allan Hancock College will hire a full time faculty member for the Machining and Manufacturing Technology program and offer at least five (5) classes in Machining and Manufacturing Technology during the Fall semester and at least five (5) classes in the Spring semester in each of the following school years, 2012-2013, 2013-2014 and 2014-2015.
- 2) Melfred Borzall, Inc. will provide Allan Hancock College with \$10,000 on August 15, 2012 for the 2012-2013 school year, \$10,000 on August 15, 2013 for the 2013-2014 school year and \$10,000 on August 15, 2014 for the 2014-2015 school year.

This MOU will remain in effect provided that each party abides by the responsibilities described above.

  
Date 4.18.12  
Dr. Jose M. Ortiz Ed.D.  
Superintendent/President of Allan Hancock College

  
Date 4/16/12  
Eric Melsheimer  
Vice President of Engineering  
Melfred Borzall, Inc.

**MELFRED  
BORZALL**

Melfred Borzall, Inc.  
2712 Airpark Dr • Santa Maria, California 93455  
Ph: (805) 739-0118 • Fax: (805) 739-0698  
www.melfredborzall.com • mail@melfredborzall.com





THE BLAINE JOHNSON FOUNDATION

Memorandum of Understanding (MOU) between  
Allan Hancock College and The Blaine Johnson Foundation

May 15, 2012

This Memorandum of Understanding (MOU) between Allan Hancock College and The Blaine Johnson Foundation will go into effect on August 15, 2012 and remain in effect until May 31, 2015.

During the period that this MOU is in effect, Allan Hancock College and The Blaine Johnson Foundation agree to the following:

- 1) Allan Hancock College will hire a full time faculty member for the Machining and Manufacturing Technology program and offer at least five (5) classes in Machining and Manufacturing Technology during the fall semester and at least five (5) classes in the Spring semester in each of the following school years, 2012-2013, 2013-2014, and 2014-2015. During this three year period the classes offered will cover the full range of courses in the program. Classes will provide industry level instruction.
- 2) The Blaine Johnson Foundation will provide Allan Hancock College Foundation with \$10,000 on August 15, 2012 for the 2012-2013 school year, \$10,000 on August 15, 2013 for the 2013-2014 school year, and \$10,000 on August 15, 2014 for the 2014-2015 school year.

This MOU will remain in effect provided that each party abides by the provisions of the MOU described above.

Dr. Jose M. Ortiz, Ed. D.

Superintendent/President of Allan Hancock College

 Date 5-16-12

Alan Johnson

President of The Blaine Johnson Foundation

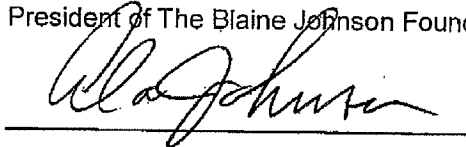
 Date 6/6/12

Delivered to Patty V.N.,  
Bs. Services  
8/14/2013

Emailed Linda  
8/13/2013

Year 1

C & D ZODIAC, INC. - SANTA MARIA 2641 AIRPARK DRIVE • SANTA MARIA, CA 93455

185486  
185486

INVOICE NO.	INVOICE DATE	AMOUNT	DISCOUNT	NET AMOUNT	CHECK TOTAL
07/2013 DO	07/26/2013	5,000.00	0.00	5,000.00	
		5,000.00	0.00		5,000.00

RECEIVED  
JUL 30 2013  
BY:

VENDOR: 0061091 CURRENCY: USD US DOLLARS

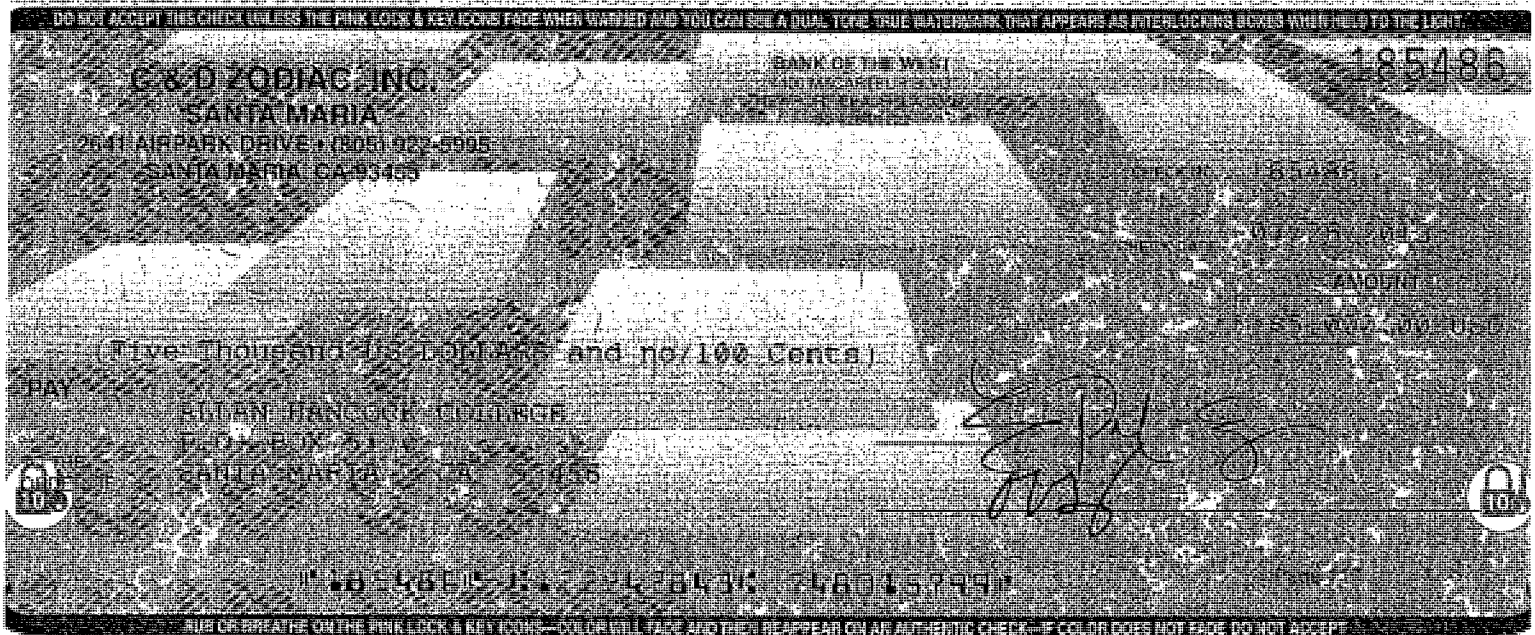

SUB OR BREATHE ON THE HINK LOCK & NEW COINS - COLOR WILL FADE AND THEN REAPPEAR ON AN AUTHENTIC CHECK - IF COLOR DOES NOT FADE DO NOT ACCEPT

Year 2

Toni delivered  
Check to PVN, BS SVCS  
on 9/20/13

ZODIAC SEAT SHELLS 2641 AIRPARK DRIVE • SANTA MARIA, CA 93455

666506

7SH00619

ALLAN HANCOCK COLLEGE

09/10/2013

666506

INVOICE NO.	INVOICE DATE	AMOUNT	DISCOUNT	NET AMOUNT	CHECK TOTAL
AHC Foundati	08/14/2013	5,000.00	0.00	5,000.00	
VENDOR: ZSH00619		5,000.00	0.00		5,000.00

L. Reed

RECEIVED  
SEP 18 2013  
BY:

CURRENCY: US\$ US DOLLARS





**Haas Factory Outlet**  
A Division of Machining Time Savers, Inc.

1338 S. State College Pkwy.  
Anaheim, CA 92806  
(714) 635-7373  
FAX (714) 635-3268

For Office Use Only	
Sales Order # SA	
Invoice #:	
Ship Date:	
Cust. #	2919

### QUOTATION

REP: GREGG MILLER	SHIP VIA: <input type="checkbox"/> W/C <input type="checkbox"/> H/C <input type="checkbox"/> TRUCK
ORDER DATE: August 25, 2011	UPS: <input type="checkbox"/> RED <input type="checkbox"/> BLUE <input type="checkbox"/> ORG <input type="checkbox"/> GRD
DELIVERY DATE:	TERMS: <b>NET15</b>
INVOICE TO: Melfred-Borzall	SHIP TO: Melfred-Borzall
2712 Air Park Drive	2712 Air Park Drive
Santa Maria, CA 93455	Santa Maria, CA 93455
CONTACT: emelsheimer@melfredborzall.com	CONTACT: Eric Melsheimer
TELEPHONE: 805-739-0118 FAX:	TELEPHONE: 805-739-0118 FAX:
P.O.#:	P.O.#:

QTY	DESCRIPTION	VENDOR	PART NO.	UNIT PRICE	AMOUNT
1	RETRO KIT BL VF 10HP SD-VD		93-1134B	\$3600.00	\$3600.00
1	+SIGMA 09 W/SEAL INSTALLED		93-0346	\$900.00	\$900.00
16	Labor@\$130.00 per hour (Estimated)			\$130.00	\$2080.00
3.5	Travel@\$85.00 per hour (Estimated)			\$85.00	\$297.50

Model: VF-3B S/N: 10173 Reason:	Subtotal
PN supplied by: Deke Haas codes: PNC <input type="checkbox"/> TLS <input type="checkbox"/> OOC <input type="checkbox"/>	Sales Tax .0775 6877.50
NCP <input type="checkbox"/> ADV <input type="checkbox"/> OPT <input type="checkbox"/> OPS <input type="checkbox"/>	Installation Charge
NOTES:	Freight: <input type="checkbox"/> EST <input type="checkbox"/> NTE <input type="checkbox"/> PPI
	<input type="checkbox"/> N/C <input type="checkbox"/> COLL <input type="checkbox"/> SPECIAL

VAN: -Select Van#-	Version: 1005	Total Due
--------------------	---------------	-----------

SALES, COUNTY & CITY TAXES ARE ADDITIONAL. FREIGHT CHARGES ON MACHINES & PERIPHERAL EQUIPMENT ARE ALSO ADDITIONAL.

Accepted by: <b>HFO, A Division Of MTS</b>	Accepted by: _____ Please Print Signature Name
By: _____ Title: _____	X: _____ Title: _____

THE CUSTOMER SIGNING ABOVE, OFFERS TO PURCHASE FROM HFO, A Division Of MTS, THE ABOVE DESCRIBED GOODS UPON THE TERMS AND CONDITIONS AS SHOWN ON ATTACHED DOCUMENT.



03/28/2012 ACMT donated 780 lbs of Aluminum solids – worth \$468 in their calculation

Listed below are my current prices for your consideration.

Aluminum Chips (clean) = .50 / lb

Aluminum Solids = .60 / lb

Yellow Brass Chips (clean) = \$1.40 / lb

Yellow Brass Solids = \$1.62 / lb

Copper Chips (clean) = \$2.40 / lb

#1 Copper Solids = \$2.60 / lb

304 Stainless Chips (clean) = .53 / lb

304 Stainless Solids = .60 /

# Santa Maria Sun / School Scene

The following articles were printed from Santa Maria Sun [santamariasun.com] - Volume 13, Issue 4  
Share:

## Employment nonprofit donates to Hancock

BY AMY ASMAN

The Santa Maria Employer Advisory Council has donated more than \$3,000 to the Allan Hancock College Industrial Technology Department to purchase cutting-edge engineering software that can be used in engineering, manufacturing, automotive, and architecture courses. Representatives from Helical Products, Inc.; the Okonite Company; and the Workforce Investment Act program recently presented a check to the college on the Santa Maria campus.

The donation will go toward an upgrade to the most current version of SolidWorks for the Computer Aided Design lab and help purchase 45 learning kits, which allow students to install the software at home to practice on their own computers. The donation will also cover the cost of videos, lesson guides, projects, and certification preparation.

"Classes using SolidWorks allow students to design individual components and compile these parts into a complete assembly. The software has application in every area of manufacturing, from the design of aerospace and medical devices to automotive parts and juvenile products," Bob Mabry, coordinator/instructor of the machine technology program, said in a press release.

"Because most of our local high schools offer SolidWorks to their students, it is also an important bridge for these students who continue their educations at Hancock," he added.

The Santa Maria Employer Advisory Council is a nonprofit corporation under the statewide California Employer Advisory Council. Volunteers provide links between business, education, government agencies, and the workforce.

Saengjaeng said that last year the EAC donated two computers to Computers for Kids, benefiting lower-income students in middle school and high school levels. The local EAC contributed at least 20 computers in the past, and is the second largest contributor to the program.

Industry members of the Santa Maria EAC include Abba Employer Services, Inc; Helical Products Company, Inc; United Launch Alliance LLC; Rancho Harvest, Inc; Select Staffing; TWIW Insurance Services, LLC; Atlas Copoc Mafi-Trench Company LLC; Your People Professionals; The Okonite Company; Central Coast Urgent Care; Santa Maria Inn; EDD and the Workforce Investment Act program.

Share:



# PURCHASE ORDER

P.O. Box 5170 Santa Maria, CA 93456-5170

**PLEASE NOTE!**  
THIS NUMBER MUST APPEAR ON ALL INVOICES, PACKAGES, SHIPPING PAPERS AND CORRESPONDENCE PERTAINING TO THIS ORDER.

**VENDOR**  
Haas Factory Outlet  
1338 S. State College Pkwy.  
ANAHEIM, CA 92806

**PURCHASE ORDER**  
**No. F14117**  
**SHIP TO**  
ALLAN HANCOCK COLLEGE  
1300 S. COLLEGE DR.  
SANTA MARIA, CA 93454

VENDOR I.D.	TERMS OF PYMNT	PHONE #	FAX #	ISSUE DATE
F08707	NET 30	(714) 635-7373	(714) 635-3268	12/06/13
REQUISITIONER	REQUISITION NUMBER	DEPT./DIVISION		
COX, MARLYN	F30129			

**MAIL INVOICES TO**  
AHC Foundation  
Accounts Payable Dept.  
P.O. Box 5170  
Santa Maria, CA 93456-5170

ITEM #	QUANTITY	UNIT	DESCRIPTION/MANUFACTURER'S PART NUMBER	PROGRAM CODE - OBJECT	UNIT PRICE	ORDER AMOUNT
0001	1	EA	MACHINE TECH EQ REPAIR **Location:** R 100	831220705650	1,370.00	1,370.00
					Estimated Sh	0.00
					Tax	0.00

**RECEIVED**  
DEC 10 2013  
BY: \_\_\_\_\_

**REQUIRED**

Material Safety Data Sheets required on all hazardous materials delivered under this order.

No goods will be received before 8:00 a.m. or after 3:00 p.m. or on Saturday, Sunday or holidays.

**FAXED**  
[ ]

*[Signature]*  
**TOTAL** 1,370.00  
NOT VALID UNLESS SIGNED

**INSTRUCTIONS**

1. Submit invoices in duplicate for each purchase order.
2. Prepay all transportation charges and state separately on invoice.
3. Packing slips must accompany all shipments; partial shipments will be accepted.
4. Make no substitutions unless authorized in writing.
5. All shipments FOB destination - prepay and add.

VENDOR





## Haas Factory Outlet

A Division of Machining Time Savers, Inc.

Arjen Sakes  
Director of Sales  
Machining Time Savers, Inc.,  
1338 South State College Parkway  
Anaheim, CA 92806  
(714) 635-7373 ext. 237

March 5, 2014

Robert Mabry, Project Director  
Central California Manufacturing Initiative  
Allan Hancock College  
800 S College Ave  
Santa Maria, CA 93454

Dear Mr. Mabry:

The Haas Factory Outlet – Anaheim, a Division of Machining Time Savers, Inc., is pleased to affirm support for ongoing collaboration and partnership with the Central California Manufacturing Initiative (CCMI), which is hosted and sponsored by the Allan Hancock Joint Community College District. I am aware that the CCMI seeks to provide the highest quality machining and manufacturing training for the California workforce. The mission, goals and objectives of the CCMI, therefore, wholly support and align with those of MTS.

In October 2013, MTS and its partner, Haas Automation, presented three HAAS control simulators to Allan Hancock College in conjunction with the school's purchase of computer-numerical-controlled machines. The value of these three simulators was \$5,085.

In January 2014, MTS presented a HA5C Indexer to Allan Hancock College. The value of this indexer was \$6,995.

We look forward to many more opportunities for collaboration with and support for the CCMI.

Sincerely,

Arjen Sakes  
Director of Sales



# NEWS RELEASE

---

**Andrew Masuda**  
Public/Sports Information Specialist  
805.922.6966 ext. 3779  
fax 805.347.9896  
andrew.masuda@hancockcollege.edu  
800 South College Drive  
Santa Maria, CA 93454-6399

September 5, 2014

## DONATION FROM SANTA MARIA EMPLOYER ADVISORY COUNCIL HELPS FURNISH NEW ADDITIONAL INDUSTRIAL TECHNOLOGY COMPUTER LAB

The industrial technology department at Allan Hancock College has moved one step closer to a new additional computer lab with a recent \$2,000 donation from the Santa Maria Employer Advisory Council (SMEAC).

"The donation to help buy computers is all about training for us," said Gina Avalos, chair of the Santa Maria Employers Advisory Council. "We are trying to bring the private and public sectors together with education at Hancock."

Currently, the industrial technology department has one computer lab and professors are eager to add a second. "There is a log jam in the existing computer lab because all the departments share the facility," said Bob Mabry, an associate professor of machining and manufacturing technology. "The new lab will allow the department to offer more computer-oriented classes and the students will be able to get more of the training they need."

The donation from the SMEAC, as well as a \$22,000 Industry-Driven Regional Collaborative grant from the California Community College Chancellor's Office, will help fund the purchase of 32 computers in the new lab.

"Whether its architecture or welding or machining, this is a computer-oriented world," said department chair Eric Mason. "More computer access for students leads to more computer-literate, skilled workers entering the local work force."

Representatives from the SMEAC and Employment Development Department hope the donation pays dividends within the local workforce.

"There is high demand for highly trained and educated employees," said Avalos. "Hancock provides the education and training that local employers need because the college helps students earn jobs on the Central Coast."

Mabry said the additional computer assisted drafting (CAD) labs will positively impact his machining and manufacturing technology students.

“There is a huge demand for machining, welding and other industrial technology fields. We will be able to add even more of our students into the pool of highly skilled workers,” said Mabry.

The new 32-station computer lab is expected to be open to students for the spring semester.

The lab is located in the college’s new Industrial Technology Complex. The \$17.6 million facility features three buildings and more than 35,000 square feet of lab space. The department consists of nine programs, including architecture, auto body technology, automotive technology, welding technology, machining and manufacturing technology, electronics/computer electronics, engineering technology, space operations and apprentice training.

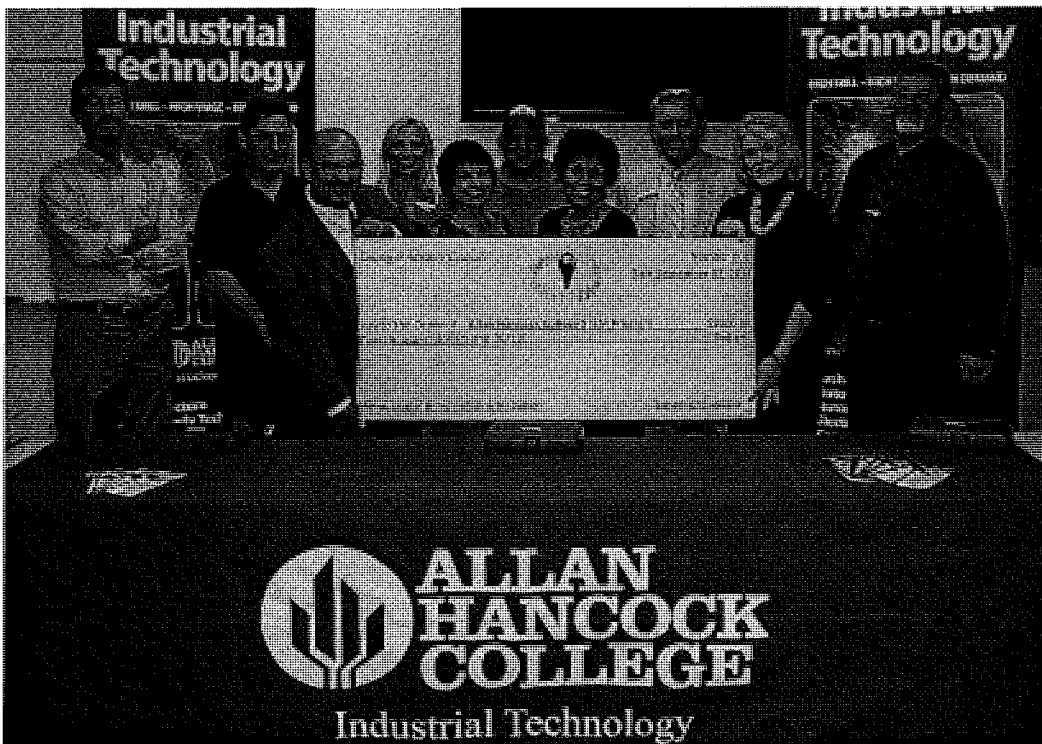

Members from the Santa Maria Employer Advisory Council donated \$2,000 to help Allan Hancock College furnish an additional computer lab for the industrial technology department. Pictured in back row (left to right) Paul Murphy, interim dean of academic affairs; Eric Mason, industrial technology department chair; interim academic dean Larissa Nazarenko; machining associate professor Bob Mabry; Superintendent/President Kevin Walthers, Ph.D. and Frank Campo with the Economic Development Department. Front row (left to right) Luciano Santini, site manager for the Economic Development Department; SMEAC/EDD coordinator Yolanda Nova; SMEAC chair Gina Avalos and SMEAC vice-chair Diane Pilloud.

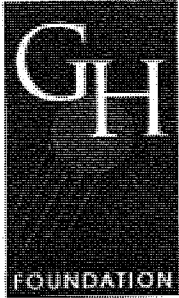

# The Gene Haas Foundation

---

2800 STURGIS ROAD, OXNARD, CA 93030

December 20, 2014

Robert Mabry  
Robert Hancock College  
800 South College Drive  
Santa Maria, CA 93454-6399

Dear Robert

The Gene Haas Foundation is pleased to enclose a check in the amount of \$<amount> as a grant to support SkillsUSA CA participation.

This grant is subject to the terms set forth in the attached Grant Terms and Conditions and, by cashing the grant-check, you are indicating that you agree to these terms.

As the Gene Haas Foundation is a 501(c)(3) nonprofit organization, it is not necessary to issue a tax receipt for this donation. If you wish to send a letter expressing your organization's appreciation of this contribution or pictures and stories about your projects please email your correspondence to [klooman@ghaasfoundation.org](mailto:klooman@ghaasfoundation.org).

The Gene Haas Foundation wishes you and your organization every success in your important work. For any questions concerning this grant, you may contact me at 805-988-6979.

Best Regards,

Kathy Looman  
Foundation Administrator

The Gene Haas Foundation  
GRANT TERMS AND CONDITIONS

**Grant Award Date:** December 21, 2014

**Grant Amount:** \$5,000

- (a) **Your Tax-Exempt Status:** You are exempt under Internal Revenue Code Section 501(c)(3) and currently are classified as a public charity pursuant to Internal Revenue Code Section 509(a)(1), (2) or (3) (an "Exempt Public Charity").
- (b) **Grant Purpose and Expenditure of Funds:** You will utilize the grant proceeds to fund programs as long as it is consistent with the tax-exempt status described above and with the mission of your organization. You will not use any of the grant, or the interest or income thereon, to influence any legislation or the outcome of any election, to conduct a voter registration drive or to satisfy a charitable pledge or obligation of any person or organization.
- (c) **Return of Grant Funds:** You will return any funds not expended within 2 years for the charitable purposes outlined above under "Grant Purpose". You also will return the enclosed donation if your organization is no longer recognized by the Internal Revenue Service as an Exempt Public Charity or would lose its status as a public charity (as per Internal Revenue Code Section 170(b)(1)(A)(vi)) as a result of this donation. Returned funds will be sent to the Foundation at 2800 Sturgis Road, Oxnard, CA 93030.
- (d) **Other Terms:** These Grant Terms and Conditions control over and supersede any conflicting terms of any document that you may have received concerning the conditions under which this grant is made and are in addition to all other terms and conditions the Foundation may have provided. This grant is subject to these Terms and Conditions and by cashing the grant check, you are indicating that you agree to its terms.  
As used herein the term "you" and the like means the recipient of the Grant. The term "Foundation" means the foundation making the Grant.

CASH ONLY IF ALL CHECKLOCK™ SECURITY FEATURES LISTED ON BACK INDICATE NO TAMPERING OR COPYING



Gene Haas Foundation  
2800 Sturjis Road  
Oxnard, CA 93030-8901

PNC BANK, NATIONAL ASSOCIATION  
Philadelphia, PA  
3-5/310

12/22/2014

1913

PAY-TO-THE ORDER OF Alan Hancock College

\$\*\*5,000.00

DOLLARS

Five thousand and 00/100

Robert Mabry  
Alan Hancock College  
800 South College Drive  
Santa Maria, CA 93454-6399

Intuit® CheckLock™ Secure Check

Details on Back

© 2011 INTUIT INC. # 474 800 X 885 0

⑈001913⑈ ⑆031000053⑆ 7032599218⑈

Gene Haas Foundation  
12/22/2014 Alan Hancock College

1913

Date	Type	Reference	Original Amount	Balance Due	Payment
12/19/2014	Bill	1017	5,000.00	5,000.00	5,000.00
			Check Amount		5,000.00

Schwab

5,000.00





# The Gene Haas Foundation

---

2800 STURGIS ROAD, OXNARD, CA 93030

February 9, 2015

Robert Mabry  
Alan Hancock College  
800 South College Drive  
Santa Maria, CA 93454-6399

Dear Robert:

The Gene Haas Foundation is pleased to enclose a check in the amount of \$15,000 as a grant to support the machine technology scholarship program

These scholarships are to be given to students currently enrolled-in or will be enrolling-in a machining-based training program at the college-level. The criteria for determining winners of these scholarships will be determined by the program instructor or a committee that includes program instructor(s).

This grant is subject to the terms set forth in the attached Grant Terms and Conditions and, by cashing the grant-check, you are indicating that you agree to these terms.

As the Gene Haas Foundation is a 501(c)(3) nonprofit organization, it is not necessary to issue a tax receipt for this donation. If you wish to send a letter expressing your organization's appreciation of this contribution or pictures and stories about your projects please email your correspondence to [klooman@ghaasfoundation.org](mailto:klooman@ghaasfoundation.org).

The Gene Haas Foundation wishes you and your organization every success in your important work. For any questions concerning this grant, you may contact me at 805-988-6979.

Best Regards,

Kathy Looman  
Foundation Administrator



The Gene Haas Foundation  
GRANT TERMS AND CONDITIONS  
Educational Institution - Scholarship

**Grant Award Date:** February 11, 2015

**Grant Amount:** \$15,000

- (a) **Your Tax-Exempt Status:** You are exempt under Internal Revenue Code Section 501(c)(3) and currently are classified as a public charity pursuant to Internal Revenue Code Section 509(a)(1), (2) or (3) (an "Exempt Public Charity").

To be a school to which the Gene Haas Foundation (herein referred to as 'Foundation') can make grants without exercising expenditure responsibility, the school must be "an educational organization which normally maintains a regular faculty and curriculum and normally has a regularly enrolled student body of pupils or students in attendance at the place where its educational activities are regularly carried on." (I.R.C. § 170(b)(1)(A)(ii)). A school is a "public charity" for this purpose. (Treas. Reg. § 1.509(a)-2(a)). This is a type of organization to which a private foundation can make grants without incurring a penalty tax or being required to exercise expenditure responsibility for those grants. (I.R.C. § 4945(d)(4)(A); Treas. Reg. § 53.4945-5(a)(1), (4)(i)). Consequently, on the assumptions stated above, the Foundation can make grants to public schools that meet the requirements set forth above. What public schools do not have is a determination letter from the IRS attesting to their status as a 501(c)(3) organization. However, to receive grant money from a private foundation like the Foundation (and to receive deductible contributions from individual taxpayers), the school does not need to be a Section 501(c)(3) organization. It only needs to meet the definition of a school quoted above. It can be an instrumentality of a state (such as a school district). It does not need to be a nonprofit corporation or a trust. However, if the school is not an instrumentality of a state, it generally must be a 501(c)(3) organization. (I.R.C. § 170(c)).

- (b) **Grant Purpose and Expenditure of Funds:** You will utilize the grant proceeds to fund programs as long as it is consistent with the tax-exempt status described above and with the mission of your organization. You will not use any of the grant, or the interest or income thereon, to influence any legislation or the outcome of any election, to conduct a voter registration drive or to satisfy a charitable pledge or obligation of any person or organization.
- (c) **Scholarship Requirements:** Funds must be expended for student machinist-based training programs. The scholarship(s) will be referred to as the "Gene Haas Scholarship" in all on-line and print materials associated with the scholarship. It is your responsibility to ensure that the process of awarding these scholarships is open and equitable to all potential students.
- (d) **Return of Grant Funds:** You will return any funds not expended within 2 years for the charitable purposes outlined above under "Grant Purpose". You also will return the enclosed donation if your organization is no longer recognized by the Internal Revenue Service as an Exempt Public Charity or would lose its status as a public charity (as per Internal Revenue Code Section 170(b)(1)(A)(vi)) as a result of this donation. Returned funds will be sent to the Foundation at 2800 Sturgis Road, Oxnard, CA 93030.
- (e) **Other Terms:** These Grant Terms and Conditions control over and supersede any conflicting terms of any document that you may have received concerning the conditions under which this grant is made and are in addition to all other terms and conditions the Foundation may have provided. This grant is subject to these Terms and Conditions and by cashing the grant check, you are indicating that you agree to its terms.

As used herein the term "you" and the like means the recipient of the Grant. The term "Foundation" means the foundation making the Grant.



Gene Haas Foundation  
2800 Sturgis Road  
Oxnard, CA 93030-8901

PNC BANK NATIONAL ASSOCIATION  
Philadelphia, PA  
3-5/310

1932

02/06/2015

PAY TO THE ORDER OF Alan Hancock College

\$\*\*15,000.00

Fifteen thousand and 00/100\*\*\*\*\*

DOLLARS

Robert Mabry  
Alan Hancock College  
800 South College Drive  
Santa Maria, CA 93454-6399

MEMO

⑈001932⑈ ⑆031000053⑆ ⑈032699248⑈

Gene Haas Foundation  
02/06/2015

Alan Hancock College

1932

Date 02/05/2015 Type Bill

Reference 1033

Original Amount 15,000.00 Balance Due 15,000.00

Payment 15,000.00 -

Check Amount

Schwab

15,000.00

DISTRICT

THIS FORM MAY NOT BE REPLICATED AND UNDER NO CIRCUMSTANCES CAN THE LANGUAGE BE ALTERED

BOG, California Community Colleges Chancellor's Office - 6870
DISTRICT USE ONLY
District (Grantee): Allan Hancock Joint CCD
College: Allan Hancock College

Grant Agreement
Economic and Workforce Development
Industry Driven Regional Collaboratives
RFA # 12 - 326
Grant Agreement No.: 12 - 326 - 207
Funding Fiscal Year 2012-13
Total Amount Encumbered : \$ 277,468

This grant is made and entered into, by and between, the BOG, California Community Colleges Chancellor's Office and the aforementioned district, hereafter referred to as the Grantee. The grant shall consist of this Grant Agreement face sheet and the Grantee's application, with all required forms. The RFA Specification and the Grant Agreement Legal Terms and Conditions (Articles I, Rev. 10/10 and II, Rev. 4/08), as set forth in the RFA Instructions are incorporated into this grant by reference.

The total amount payable for this grant shall not exceed the amount specified above as "Amount Encumbered".

The term of this grant shall be from November 15, 2012 to January 31, 2014. The Final Report must be submitted within 60 of the grant end date.

Funding under this grant is contingent upon the availability of funds, and is subject to any additional restrictions, limitations or conditions enacted in the state budget and/or Executive Orders that may affect the provisions, term, or funding of this agreement in any manner.

GRANTEE

Project Director: Robert Mabry, Instructor
Total Grant Funds Requested: \$ 277,468
Total Match Funds, (if applicable): \$ 148,695.00

Signature, Chief Executive Officer (or authorized Designee)
Elizabeth A. Miller, Ed.D. Interim Superintendent/Pres.
Date: 1/8/13

Print Name/Title of Person Signing: Elizabeth A. Miller, Ed.D. Interim Superintendent/Pres.
District Address: 800 S. College Dr. Santa Maria, CA 93454

STATE OF CALIFORNIA

Project Monitor: Katie Faires
Agency Address: 1102 Q Street, Suite 4554 Sacramento, CA 95811-6539

Table with 6 columns: Item, Object of Expenditure, Chapter, Statute, Fiscal Year, Amount. Row 1: 6870 - 101 - 0001 (16), 3235 - 751 - 23505, 21, 2012, 2012-13, \$ 277,468. Total Amount Encumbered : \$ 277,468

Signature, Accounting Manager (or Authorized Designee)
Date: 1/28/13

Signature, Executive Vice Chancellor (or authorized Designee)
Date: FEB 05 2013

Print Name/Title of Person Signing: Steve Bruckman, Executive Vice Chancellor

**THIS FORM MAY NOT BE REPLICATED  
AND UNDER NO CIRCUMSTANCES CAN THE LANGUAGE BE ALTERED**

BOG, California Community Colleges Chancellor's Office - 6870

**DISTRICT USE ONLY**  
District (Grantee): Allan Hancock Joint CCD  
College: Allan Hancock College

**Grant Agreement-Amended**

**BOG-CCCCO USE ONLY**

**AMENDMENT # 1**

**Grant Agreement No.: 12 - 326 - 207**

**Workforce and Economic Development**

Funding Fiscal Year <u>2012-13</u>	Prior Amount Encumbered : \$	277,468
	Amount To Be _____ : \$	-
	Amount Encumbered : \$	277,468

**Industry Driven Regional Collaboratives**

Funding Fiscal Year <u>2013-14</u>	Prior Amount Encumbered : \$	-
	Amount To Be <u>Augmented</u> : \$	36,144
	Amount Encumbered : \$	36,144
	<b>Total Amount Encumbered : \$</b>	<b>313,612</b>

RFA # 12 - 326

On this 1st day of July 2013, the BOG, California Community Colleges Chancellor's Office and the aforementioned district hereby agree to amend this grant agreement as follows:

- \* This Grant Agreement is to be augmented with additional Economic and Workforce Development funds in the amount of \$36,144. The amount awarded for this Grant Agreement for FY 2013-14 is \$36,144.
- \* Performance period for FY 2013-14 funds is July 1, 2013 through June 30, 2014. The final report must be submitted within 60 days of the grant performance date.
- \* The total amount of this Grant Agreement shall not exceed \$313,612.

Funding under this grant is contingent upon the availability of funds, and is subject to any additional restrictions, limitations or conditions enacted in the state budget and/or Executive Orders that may affect the provisions, term, or funding of this agreement in any manner.

All other terms and conditions remain the same.

**GRANTEE**

Project Director: Robert Mabry  
Total Grant Funds: \$ 313,612  
Total Match Funds, (if applicable): \_\_\_\_\_

Signature, Chief Executive Officer (or authorized Designee):  Date: 7/22/13

Print Name/Title of Person Signing: Kevin G. Walthers, Ph.D. Superintendent/President  
District Address: 800 S. College Drive Santa Maria, CA 93454

**STATE OF CALIFORNIA**

Project Monitor: Katie Gilks  
Agency Address: 1102 Q Street, Suite 4554 Sacramento, CA 95811-6539

Item:	Object of Expenditure	Chapter	Statute	Fiscal Year	Amount
6870 - 101 - 0001 (16)	3235 - 751 - 23505	21	2012	2012-13	\$ 277,468
-	-	-	-	-	-
<b>Amount Encumbered : \$</b>					<b>277,468</b>
6870 - 101 - 0001 (17)	3235 - 751 - 23505	20	2013	2013-14	\$ 36,144
-	-	-	-	-	-
<b>Amount Encumbered : \$</b>					<b>36,144</b>
<b>Total Amount Encumbered : \$</b>					<b>313,612</b>

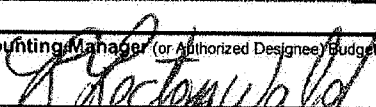
Signature, Accounting Manager (or Authorized Designee):  Budgeted funds are available for the period and purpose of the expenditures stated above. Date: 10/11/13

Signature, Executive Vice Chancellor (or authorized Designee):  Date: **OCT 14 2013**

Print Name/Title of Person Signing: Steve Bruckman, Executive Vice Chancellor

ALLAN HANCOCK JOINT COMMUNITY COLLEGE DISTRICT  
 800 SOUTH COLLEGE DR  
 SANTA MARIA, CA 93454-6399

**AGREEMENT FOR CONTRACT INSTRUCTION  
 (NOT-FOR-CREDIT INSTRUCTION)**

The purpose of this agreement is to establish a cooperative relationship between **Allan Hancock College Joint Community College District**, 800 South College Drive, Santa Maria, CA 93454, hereinafter referred to as "CONTRACTOR," and **Zodiac Aerospace**, 2641 Airpark Drive, Santa Maria, CA 93454, hereinafter referred to as "RECIPIENT," defining roles and responsibilities of both parties.

**IN CONSIDERATION OF THE TERMS OF THE AGREEMENT**, CONTRACTOR and RECIPIENT mutually agree as follows:

1. CONTRACTOR represents that it is a public post-secondary institution with the capability and the experience to provide services in the area of print reading, inspection and measurement techniques at the post-secondary level.
2. Facilities will be provided by RECIPIENT to conduct the program specified herein. They shall meet the requirements of state and local safety and health regulations during the term of the Agreement.
3. RECIPIENT and CONTRACTOR will honor the schedule of meeting times mutually agreed upon beginning no earlier than October 14, 2013 and not to exceed June 30, 2014.
4. The location of the services shall be: 2641 Airpark Drive, Santa Maria, CA 93454
5. CONTRACTOR shall provide the following:
  - a) Qualified Instructor
  - b) Curriculum
  - c) Assessments
6. Should RECIPIENT require additional services in any of the above components, the fee shall be negotiated separately.
7. The instructor(s) shall be a mutually agreed upon qualified instructor.
8. All participants shall be under the direction and supervision of the instructor as specified herein.
9. Payment of Three Thousand and  $\frac{00}{100}$  Dollars for program delivery is due one week prior to the start of instruction.
10. CONTRACTOR represents that all operations of its business are and will continue to be conducted in compliance with Title VI and VII of the Civil Rights Act of 1964; Title IX of the Higher Education Act of 1972, the Privacy Rights of Parents and Students Act of 1974, and all applicable local, state and federal health and safety regulations.
11. RECIPIENT agrees not to enter into a competitive agreement for these services with the instructor(s) or consultant(s) provided by CONTRACTOR for a period of one year following the conclusion of this agreement.
12. CONTRACTOR retains the right to cancel any course that is offered under this agreement no later than 10 days before the first meeting of the class. RECIPIENT retains the right to cancel any course that is offered under this agreement no later than 10 days before the first meeting of the class.

**COPY**

**TERMS:**

Either party may terminate this agreement at the end of any fiscal year by giving written notice sixty (60) days prior to the end of a fiscal year. Further, either party may terminate this agreement in thirty (30) days if the other party fails to fulfill any of the terms of this agreement. This clause is initiated by written notice that identifies the cause for action and the effective date of termination.

Persons responsible for implementation of this agreement:

ALLAN HANCOCK JOINT COMM COLLEGE DISTRICT

Robert Mabry

Project Director, Central Coast Manufacturing Initiative (CCMI)

Phone: (805) 922-6966 X 3487

[rmabry@hancockcollege.edu](mailto:rmabry@hancockcollege.edu)

ZODIAC AEROSPACE

Stacey Limon

Training Coordinator

Phone (805) 922-5995 X 212

[Stacey.Limon@zodiac aerospace.com](mailto:Stacey.Limon@zodiac aerospace.com)

RECIPIENT, in order to protect the CONTRACTOR, its officers, employees, contractors and agents, against claims and liability for death, injury, loss and damage arising out of or in any manner connected with the performance and operation of the terms of this agreement, shall provide and maintain in force during the entire term of this agreement, proof of insurance or an approved program of self-insurance in the amount of not less than ONE MILLION DOLLARS (\$1,000,000) per incident, and property damage insurance of not less than ONE HUNDRED THOUSAND DOLLARS (\$100,000) per accident with a reliable insurance carrier authorized to do such public liability and property damage insurance business in the state of California. ~~Said policy of insurance or program of self-insurance shall expressly name the CONTRACTOR, its agents, employees and officers as an additional insured for the purposes of this agreement. A certificate of insurance including such endorsement shall be furnished to the CONTRACTOR.~~ *Proof of coverage to be provided by Recipient*

RECIPIENT agrees to and shall indemnify, save and hold harmless the CONTRACTOR and its officers, employees, contractors, representatives and agents from any and all claims, demands, liabilities, costs, expenses, damages, causes of action, losses, and judgments, arising out of the performance of or in connection with this Agreement. The obligation to indemnify shall extend to all claims and losses that arise from the negligence of the RECIPIENT, its officers, employees, contractors, representatives or agents.

CONTRACTOR agrees to and shall indemnify, save and hold harmless the RECIPIENT, and its officers, agents, participating agencies and employees each of its agency members and each of their officers, employees, contractors, representatives or agents, from any and all claims, demands, liabilities, costs, expenses, damages, causes of action, losses, and judgments, arising out of the performance of or in connection with this Agreement. The obligation to indemnify shall extend to all claims and losses that arise from the negligence of the CONTRACTOR, its officers, employees, contractors, representatives or agents.

RECIPIENT affirms to CONTRACTOR that it shall not discriminate against any person in any aspect of education or employment, on the basis of race, color, ancestry, religion, gender, marital status, national origin, ethnic identification, age, sexual orientation, mental or physical disability, medical condition or status as a Vietnam-era veteran.

**APPROVED:**

**CONTRACTOR**

Allan Hancock Joint Community College District

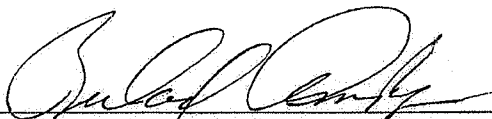

By: Richard Carmody  
Director, Business Services

10/10/13

Date

**RECIPIENT**

Zodiac Aerospace

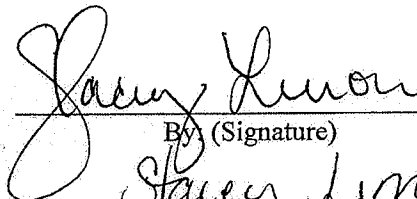

By (Signature)

Stacey Limon

Printed Name

Trainer

Title

10-2-13

Date

45-513-5867

Employer Identification Number (EIN)

ALLAN HANCOCK JOINT COMMUNITY COLLEGE DISTRICT  
800 SOUTH COLLEGE DR  
SANTA MARIA, CA 93454-6399

**AGREEMENT FOR CONTRACT INSTRUCTION  
(NOT-FOR-CREDIT INSTRUCTION)**

The purpose of this agreement is to establish a cooperative relationship between **Allan Hancock College Joint Community College District**, 800 South College Drive, Santa Maria, CA 93454, hereinafter referred to as "CONTRACTOR," and **Zodiac Aerospace**, 2641 Airpark Drive, Santa Maria, CA 93454, hereinafter referred to as "RECIPIENT," defining roles and responsibilities of both parties.

**IN CONSIDERATION OF THE TERMS OF THE AGREEMENT**, CONTRACTOR and RECIPIENT mutually agree as follows:

1. CONTRACTOR represents that it is a public post-secondary institution with the capability and the experience to provide services in the area of 3 axis Mastercam X7 Cad/Cam training at the post-secondary level.
2. Facilities will be provided by RECIPIENT to conduct the program specified herein. They shall meet the requirements of state and local safety and health regulations during the term of the Agreement.
3. RECIPIENT and CONTRACTOR will honor the schedule of meeting times mutually agreed upon beginning no earlier than October 7, 2013 and not to exceed June 30, 2014.
4. The location of the services shall be: 2641 Airpark Drive, Santa Maria, CA 93454
5. CONTRACTOR shall provide the following:
  - a) Qualified Instructor
  - b) Curriculum
  - c) Five computers and licensed Mastercam X7 software
  - d) Assessments
6. Should RECIPIENT require additional services in any of the above components, the fee shall be negotiated separately.
7. The instructor(s) shall be a mutually agreed upon qualified instructor.
8. All participants shall be under the direction and supervision of the instructor as specified herein.
9. Payment of Five Thousand Sixty and  $\frac{00}{100}$  Dollars for program delivery and travel expenses is due one week prior to the start of instruction.
10. CONTRACTOR represents that all operations of its business are and will continue to be conducted in compliance with Title VI and VII of the Civil Rights Act of 1964; Title IX of the Higher Education Act of 1972, the Privacy Rights of Parents and Students Act of 1974, and all applicable local, state and federal health and safety regulations.
11. RECIPIENT agrees not to enter into a competitive agreement for these services with the instructor(s) or consultant(s) provided by CONTRACTOR for a period of one year following the conclusion of this agreement.
12. CONTRACTOR retains the right to cancel any course that is offered under this agreement no later than 10 days before the first meeting of the class. RECIPIENT retains the right to cancel any course that is offered under this agreement no later than 10 days before the first meeting of the class.

**COPY**



**TERMS:**

Either party may terminate this agreement at the end of any fiscal year by giving written notice sixty (60) days prior to the end of a fiscal year. Further, either party may terminate this agreement in thirty (30) days if the other party fails to fulfill any of the terms of this agreement. This clause is initiated by written notice that identifies the cause for action and the effective date of termination.

Persons responsible for implementation of this agreement:

ALLAN HANCOCK JOINT COMM COLLEGE DISTRICT

Robert Mabry  
Project Director, Central Coast Manufacturing Initiative (CCMI)  
Phone: (805) 922-6966 X 3487  
[rmabry@hancockcollege.edu](mailto:rmabry@hancockcollege.edu)

ZODIAC AEROSPACE

Stacey Limon  
Training Coordinator  
Phone (805) 922-5995 X 212  
[Stacey.Limon@zodiacaerospace.com](mailto:Stacey.Limon@zodiacaerospace.com)

RECIPIENT, in order to protect the CONTRACTOR, its officers, employees, contractors and agents, against claims and liability for death, injury, loss and damage arising out of or in any manner connected with the performance and operation of the terms of this agreement, shall provide and maintain in force during the entire term of this agreement, proof of insurance or an approved program of self-insurance in the amount of not less than ONE MILLION DOLLARS (\$1,000,000) per incident, and property damage insurance of not less than ONE HUNDRED THOUSAND DOLLARS (\$100,000) per accident with a reliable insurance carrier authorized to do such public liability and property damage insurance business in the state of California. ~~Said policy of insurance or program of self-insurance shall expressly name the CONTRACTOR, its agents, employees and officers as an additional insured for the purposes of this agreement.~~ A certificate of insurance including such endorsement shall be furnished to the CONTRACTOR. *Proof coverage to be provided by Recipient*

RECIPIENT agrees to and shall indemnify, save and hold harmless the CONTRACTOR and its officers, employees, contractors, representatives and agents from any and all claims, demands, liabilities, costs, expenses, damages, causes of action, losses, and judgments, arising out of the performance of or in connection with this Agreement. The obligation to indemnify shall extend to all claims and losses that arise from the negligence of the RECIPIENT, its officers, employees, contractors, representatives or agents.

CONTRACTOR agrees to and shall indemnify, save and hold harmless the RECIPIENT, and its officers, agents, participating agencies and employees each of its agency members and each of their officers, employees, contractors, representatives or agents, from any and all claims, demands, liabilities, costs, expenses, damages, causes of action, losses, and judgments, arising out of the performance of or in connection with this Agreement. The obligation to indemnify shall extend to all claims and losses that arise from the negligence of the CONTRACTOR, its officers, employees, contractors, representatives or agents.

RECIPIENT affirms to CONTRACTOR that it shall not discriminate against any person in any aspect of education or employment, on the basis of race, color, ancestry, religion, gender, marital status, national origin, ethnic identification, age, sexual orientation, mental or physical disability, medical condition or status as a Vietnam-era veteran.

**APPROVED:**

**CONTRACTOR**

Allan Hancock Joint Community College District

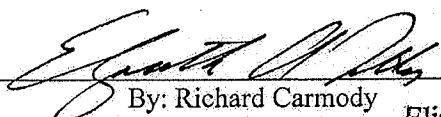

By: Richard Carmody  
Director, Business Services **Elizabeth A. Miller, Ed.D.**  
Vice President, Administrative Services

10/31/13  
Date

**RECIPIENT**

Zodiac Aerospace

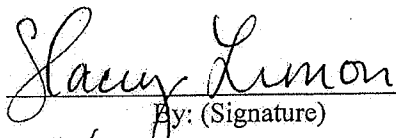

By: (Signature)

Stacey Limon

Printed Name

Training Coordinator

Title

10-22-13

Date

45-5135867

Employer Identification Number (EIN)

ALLAN HANCOCK JOINT COMMUNITY COLLEGE DISTRICT  
800 SOUTH COLLEGE DR  
SANTA MARIA, CA 93454-6399

**AGREEMENT FOR CONTRACT INSTRUCTION  
(NOT-FOR-CREDIT INSTRUCTION)**

The purpose of this agreement is to establish a cooperative relationship between **Allan Hancock College Joint Community College District**, 800 South College Drive, Santa Maria, CA 93454, hereinafter referred to as "CONTRACTOR," and **Zodiac Aerospace**, 2641 Airpark Drive, Santa Maria, CA 93454, hereinafter referred to as "RECIPIENT," defining roles and responsibilities of both parties.

**IN CONSIDERATION OF THE TERMS OF THE AGREEMENT**, CONTRACTOR and RECIPIENT mutually agree as follows:

1. CONTRACTOR represents that it is a public post-secondary institution with the capability and the experience to provide services in the area of 3 and 5 axis Mastercam X7 Cad/Cam training at the post-secondary level.
2. Facilities will be provided by RECIPIENT to conduct the program specified herein. They shall meet the requirements of state and local safety and health regulations during the term of the Agreement.
3. RECIPIENT and CONTRACTOR will honor the schedule of meeting times mutually agreed upon beginning no earlier than December 6, 2013 and not to exceed January 31, 2014.
4. The location of the services shall be: 2641 Airpark Drive, Santa Maria, CA 93454
5. CONTRACTOR shall provide the following:
  - a) Qualified Instructor
  - b) Curriculum
  - c) Five computers and licensed Mastercam X7 software
  - d) Assessments
6. Should RECIPIENT require additional services in any of the above components, the fee shall be negotiated separately.
7. The instructor(s) shall be a mutually agreed upon qualified instructor.
8. All participants shall be under the direction and supervision of the instructor as specified herein.
9. Payment of Five Thousand One Hundred Ninety and  $\frac{00}{100}$  Dollars for program delivery and travel expenses is due one week prior to the start of instruction.
10. CONTRACTOR represents that all operations of its business are and will continue to be conducted in compliance with Title VI and VII of the Civil Rights Act of 1964; Title IX of the Higher Education Act of 1972, the Privacy Rights of Parents and Students Act of 1974, and all applicable local, state and federal health and safety regulations.
11. RECIPIENT agrees not to enter into a competitive agreement for these services with the instructor(s) or consultant(s) provided by CONTRACTOR for a period of one year following the conclusion of this agreement.
12. CONTRACTOR retains the right to cancel any course that is offered under this agreement no later than 10 days before the first meeting of the class. RECIPIENT retains the right to cancel any course that is offered under this agreement no later than 10 days before the first meeting of the class.

**TERMS:**

Either party may terminate this agreement at the end of any fiscal year by giving written notice sixty (60) days prior to the end of a fiscal year. Further, either party may terminate this agreement in thirty (30) days if the other party fails to fulfill any of the terms of this agreement. This clause is initiated by written notice that identifies the cause for action and the effective date of termination.

Persons responsible for implementation of this agreement:

ALLAN HANCOCK JOINT COMM COLLEGE DISTRICT

Robert Mabry  
Project Director, Central Coast Manufacturing Initiative (CCMI)  
Phone: (805) 922-6966 X 3487  
[rmabry@hancockcollege.edu](mailto:rmabry@hancockcollege.edu)

ZODIAC AEROSPACE

Stacey Limon  
Training Coordinator  
Phone (805) 922-5995 X 212  
[Stacey.Limon@zodiacaerospace.com](mailto:Stacey.Limon@zodiacaerospace.com)

RECIPIENT, in order to protect the CONTRACTOR, its officers, employees, contractors and agents, against claims and liability for death, injury, loss and damage arising out of or in any manner connected with the performance and operation of the terms of this agreement, shall provide and maintain in force during the entire term of this agreement, proof of insurance or an approved program of self-insurance in the amount of not less than ONE MILLION DOLLARS (\$1,000,000) per incident, and property damage insurance of not less than ONE HUNDRED THOUSAND DOLLARS (\$100,000) per accident with a reliable insurance carrier authorized to do such public liability and property damage insurance business in the state of California. Proof of coverage shall be provided by recipient.

RECIPIENT agrees to and shall indemnify, save and hold harmless the CONTRACTOR and its officers, employees, contractors, representatives and agents from any and all claims, demands, liabilities, costs, expenses, damages, causes of action, losses, and judgments, arising out of the performance of or in connection with this Agreement. The obligation to indemnify shall extend to all claims and losses that arise from the negligence of the RECIPIENT, its officers, employees, contractors, representatives or agents.

CONTRACTOR agrees to and shall indemnify, save and hold harmless the RECIPIENT, and its officers, agents, participating agencies and employees each of its agency members and each of their officers, employees, contractors, representatives or agents, from any and all claims, demands, liabilities, costs, expenses, damages, causes of action, losses, and judgments, arising out of the performance of or in connection with this Agreement. The obligation to indemnify shall extend to all claims and losses that arise from the negligence of the CONTRACTOR, its officers, employees, contractors, representatives or agents.

RECIPIENT affirms to CONTRACTOR that it shall not discriminate against any person in any aspect of education or employment, on the basis of race, color, ancestry, religion, gender, marital status, national origin, ethnic identification, age, sexual orientation, mental or physical disability, medical condition or status as a Vietnam-era veteran.

APPROVED:

**CONTRACTOR**

Allan Hancock Joint Community College District

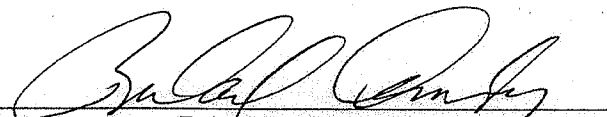

By: Richard Carmody  
Director, Business Services

12/13/13

Date

**RECIPIENT**

Zodiac Aerospace

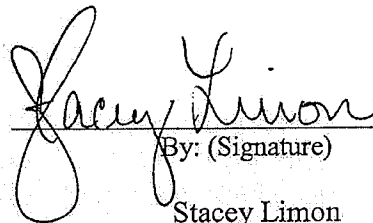

By: (Signature)

Stacey Limon  
Printed Name

Training Coordinator  
Title

45-513-5867

Date

45-5135867

Employer Identification Number (EIN)

ALLAN HANCOCK JOINT COMMUNITY COLLEGE DISTRICT  
800 SOUTH COLLEGE DR  
SANTA MARIA, CA 93454-6399

**AGREEMENT FOR CONTRACT INSTRUCTION  
(NOT-FOR-CREDIT INSTRUCTION)**

The purpose of this agreement is to establish a cooperative relationship between **Allan Hancock College Joint Community College District**, 800 South College Drive, Santa Maria, CA 93454, hereinafter referred to as "CONTRACTOR," and Zodiac Aerospace, 2641 Airpark Drive, Santa Maria, CA 93454, hereinafter referred to as "RECIPIENT," defining roles and responsibilities of both parties.

**IN CONSIDERATION OF THE TERMS OF THE AGREEMENT**, CONTRACTOR and RECIPIENT mutually agree as follows:

1. CONTRACTOR represents that it is a public post-secondary institution with the capability and the experience to provide services in the area of print reading, inspection and measurement techniques at the post-secondary level.
2. Facilities will be provided by recipient to conduct the program specified herein. They shall meet the requirements of state and local safety and health regulations during the term of the Agreement.
3. RECIPIENT and CONTRACTOR will honor the schedule of meeting times mutually agreed upon beginning no earlier than February 1, 2015 and not to exceed June 30, 2015.
4. The location of the services shall be: 2641 Airpark Drive, Santa Maria, Ca 93454
5. CONTRACTOR shall provide the following:
  - a) Qualified Instructor
  - b) Curriculum
  - c) Assessments
6. Should RECIPIENT require additional services in any of the above components, the fee shall be negotiated separately.
7. The instructor(s) shall be Alex Ek or other qualified instructor as mutually agreed upon.
8. All participants shall be under the direction and supervision of the instructor as specified herein.
9. Payment of Three Thousand and 00/100 Dollars for program delivery is due one week prior to the start of instruction.
10. CONTRACTOR represents that all operations of its business are and will continue to be conducted in compliance with Title VI and VII of the Civil Rights Act of 1964; Title IX of the Higher Education Act of 1972, the Privacy Rights of Parents and Students Act of 1974, and all applicable local, state and federal health and safety regulations.
11. RECIPIENT agrees not to enter into a competitive agreement for these services with the instructor(s) or consultant(s) provided by CONTRACTOR for a period of one year following the conclusion of this agreement.
12. CONTRACTOR retains the right to cancel any course that is offered under this agreement no later than 10 days before the first meeting of the class. RECIPIENT retains the right to cancel any course that is offered under this agreement no later than 10 days before the first meeting of the class.

**TERMS:**

Either party may terminate this agreement at the end of any fiscal year by giving written notice sixty (60) days prior to the end of a fiscal year. Further, either party may terminate this agreement in thirty (30) days if the other party fails to fulfill any of the terms of this agreement. This clause is initiated by written notice that identifies the cause for action and the effective date of termination.

Persons responsible for implementation of this agreement:

ALLAN HANCOCK JOINT COMM COLLEGE DISTRICT

Robert Mabry

Associate Professor of Machining and Mfg

Phone: (805) 922-6966 x 3487

Email: rmabry@hancockcollege.edu

ZODIAC AEROSPACE

Stacey Limon

Training Coordinator

(805) 922-5995 x 212

Stacey.Limon@zodiaceerospace.com

RECIPIENT, in order to protect the CONTRACTOR, its officers, employees, contractors and agents, against claims and liability for death, injury, loss and damage arising out of or in any manner connected with the performance and operation of the terms of this agreement, shall provide and maintain in force during the entire term of this agreement, proof of insurance or an approved program of self-insurance in the amount of not less than ONE MILLION DOLLARS (\$1,000,000) per incident, and property damage insurance of not less than ONE HUNDRED THOUSAND DOLLARS (\$100,000) per accident with a reliable insurance carrier authorized to do such public liability and property damage insurance business in the state of California. Proof of coverage to be provided by recipient.

RECIPIENT agrees to and shall indemnify, save and hold harmless the CONTRACTOR and its officers, employees, contractors, representatives and agents from any and all claims, demands, liabilities, costs, expenses, damages, causes of action, losses, and judgments, arising out of the performance of or in connection with this Agreement. The obligation to indemnify shall extend to all claims and losses that arise from the negligence of the RECIPIENT, its officers, employees, contractors, representatives or agents.

CONTRACTOR agrees to and shall indemnify, save and hold harmless the RECIPIENT, and its officers, agents, participating agencies and employees each of its agency members and each of their officers, employees, contractors, representatives or agents, from any and all claims, demands, liabilities, costs, expenses, damages, causes of action, losses, and judgments, arising out of the performance of or in connection with this Agreement. The obligation to indemnify shall extend to all claims and losses that arise from the negligence of the CONTRACTOR, its officers, employees, contractors, representatives or agents.

RECIPIENT affirms to CONTRACTOR that it shall not discriminate against any person in any aspect of education or employment, on the basis of race, color, ancestry, religion, gender, marital status, national origin, ethnic identification, age, sexual orientation, mental or physical disability, medical condition or status as a Vietnam-era veteran.

APPROVED:

CONTRACTOR

Allan Hancock Joint Community College District

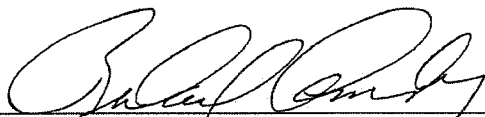

By: Richard Carmody  
Director, Business Services

1/28/15

Date

RECIPIENT

Zodiac Aerospace

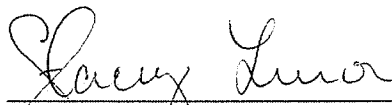

By: (Signature)

Stacy Lemon

Printed Name

Training Coordinator

Title

1-22-15

Date

45-5135867

Employer Identification Number (EIN)



# Appendix E – Employment Outcomes and Projections

## 4. Employment Outcomes and Projections



State of California

Employment Development Department

[Office Locator](#) | [Forms & Publications](#) | [Online Services](#) | [en Español](#)

Search

[This Site](#)

[California](#)



[Home](#)

[Unemployment](#)

[Disability](#)

[Jobs & Training](#)

[Payroll Taxes](#)

[Labor Market Info](#)

### Occupational Projections of Employment

[Restart](#)

[Back](#)

[Print](#)

[Download](#)

[Help with Download](#)

Page 1 of 1 (20 results/page)

<a href="#">Area</a>	<a href="#">Code</a>	<a href="#">Occupation</a>	<a href="#">Est Yr-Proj Yr</a>	<a href="#">Annual Openings Due to Growth</a>
California	514000	Metal Workers and Plastic Workers	2012 - 2022	1,080
California	514011	Computer-Controlled Machine Tool Operators, Metal and Plasti	2012 - 2022	140
California	514032	Drilling and Boring Machine Tool Operators, Metal and Plasti	2012 - 2022	0
California	514035	Milling and Planing Machine Operators, Metal and Plastic	2012 - 2022	0
California	514041	Machinists	2012 - 2022	520
California	514081	Multiple Machine Tool Setters, Operators, and Tenders, Metal	2012 - 2022	0
California	537063	Machine Feeders and Offbearers	2012 - 2022	100

[Back to Top](#) | [Contact EDD](#) | [Conditions of Use](#) | [Privacy Policy](#) | [Equal Opportunity Notice](#) | [Mobile Site](#) | [Información en Español](#) | [Site Map](#)

The Employment Development Department is an equal opportunity employer/program.  
 Auxiliary aids and services are available upon request to individuals with disabilities.  
 Copyright © 2014 State of California

### Industry Employment (CES)

Page 1 of 1 (20 results/page)

Year	Period	Area	Series code	Industry	Adjusted	Benchmark	No. of Employed
2015	Jan	San Luis Obispo County	30000000	Manufacturing	Not Adj	2014	6,800
2015	Jan	Santa Barbara County	30000000	Manufacturing	Not Adj	2014	12,500



State of California

Employment Development Department

Office Locator | Forms & Publications | Online Services | en Español

Search

This Site

California



Home Unemployment Disability Jobs & Training Payroll Taxes Labor Market Info

Occupational Projections of Employment

Restart Back Print Download  
Help with Download

Page 1 of 1 (20 results/page)

Area	Code	Occupation	Est Yr-Proj Yr	Total Annual Openings
Santa Barbara County	514000	Metal Workers and Plastic Workers	2012 - 2022	58
Santa Barbara County	514011	Computer-Controlled Machine Tool Operators, Metal and Plasti	2012 - 2022	7
Santa Barbara County	514041	Machinists	2012 - 2022	15
Santa Barbara County	514081	Multiple Machine Tool Setters, Operators, and Tenders, Metal	2012 - 2022	6

Back to Top | Contact EDD | Conditions of Use | Privacy Policy | Equal Opportunity Notice | Mobile Site | Información en Español | Site Map

The Employment Development Department is an equal opportunity employer/program.  
Auxiliary aids and services are available upon request to individuals with disabilities.  
Copyright © 2014 State of California



State of California

# Employment Development Department

[Office Locator](#) | [Forms & Publications](#) | [Online Services](#) | [en Español](#)

Search

[This Site](#)

[California](#)



[Home](#)   [Unemployment](#)   [Disability](#)   [Jobs & Training](#)   [Payroll Taxes](#)   [Labor Market Info](#)

## Occupational Projections of Employment

[Restart](#)   [Back](#)   [Print](#)   [Download](#)  
Help with Download

Page 1 of 1 (20 results/page)

Area	Code	Occupation	Est Yr-Proj Yr	Total Annual Openings
San Luis Obispo County	514000	Metal Workers and Plastic Workers	2012 - 2022	49
San Luis Obispo County	514041	Machinists	2012 - 2022	27

[Back to Top](#) | [Contact EDD](#) | [Conditions of Use](#) | [Privacy Policy](#) | [Equal Opportunity Notice](#) | [Mobile Site](#) | [Información en Español](#) | [Site Map](#)

The Employment Development Department is an equal opportunity employer/program.  
Auxiliary aids and services are available upon request to individuals with disabilities.  
Copyright © 2014 State of California

[Back](#)

## Computer-Controlled Machine Tool Operators

(SOC Code : 51-4011)  
in California

Operate computer-controlled machines or robots to perform one or more machine functions on metal or plastic work pieces.

Employers usually expect an employee in this occupation to be able to do the job after Moderate-term on-the-job training (1-12 months) .

View a [Career Video](#) for this occupation from America's Career InfoNet (requires [Windows Media Player](#))

### Occupational Wages

[\[Top\]](#)

Area	Year	Period	Hourly Mean	Hourly by Percentile		
				25th	Median	75th
California	2014	1st Qtr	\$19.09	\$14.44	\$18.12	\$22.85

[View Wages for All Areas](#) [About Wages](#)

### Occupational Projections of Employment (also called "Outlook" or "Demand")

[\[Top\]](#)

Area	Estimated Year-Projected Year	Employment		Employment Change		Annual Avg Openings
		Estimated	Projected	Number	Percent	
California	2012 - 2022	8,600	10,000	1,400	16.3	380

[View Projections for All Areas](#) [About Projections](#)

### Job Openings from JobCentral National Labor Exchange

[\[Top\]](#)

Enter a Zip Code [Find a Zip code in California](#)

Within 25 miles of Zip Code.

### Industries Employing This Occupation (click on Industry Title to View Employers List)

[\[Top\]](#)

Industry Title	Number of Employers in State of California		Percent of Total Employment for Occupation in State of California

<u>Machine Shops and Threaded Products</u>	4,163	20.1%
<u>Aerospace Product &amp; Parts Manufacturing</u>	292	16.4%
<u>Semiconductor and Electronic Components</u>	1,733	11.7%
<u>Metalworking Machinery Manufacturing</u>	753	7.7%
<u>Architectural and Structural Metals</u>	1,757	4.4%
<u>Other Fabricated Metal Product Mfg</u>	892	4.3%
<u>Electronic Instrument Manufacturing</u>	1,109	4.2%
<u>Medical Equipment and Supplies Mfg</u>	3,022	3.5%
<u>Other General Purpose Machinery Mfg</u>	1,332	3.0%
<u>Communications Equipment Manufacturing</u>	445	1.5%
<u>Other Miscellaneous Manufacturing</u>	7,095	1.1%

### About Staffing Patterns

---

### **Training Programs (click on title for more information)**

[\[Top\]](#)

Program Title

Machine Shop Technology/Assistant

### About Training & Apprenticeships

---

### **About This Occupation (from O\*NET - The Occupation Information Network)**

[\[Top\]](#)

Top Tasks (Specific duties and responsibilities of this job.)

Measure dimensions of finished workpieces to ensure conformance to specifications, using precision measuring instruments, templates, and fixtures.

Mount, install, align, and secure tools, attachments, fixtures, and workpieces on machines, using hand tools and precision measuring instruments.

Stop machines to remove finished workpieces or to change tooling, setup, or workpiece placement, according to required machining sequences.

Transfer commands from servers to computer numerical control (CNC) modules, using computer network links.

Check to ensure that workpieces are properly lubricated and cooled during machine operation.

Insert control instructions into machine control units to start operation.

Set up and operate computer-controlled machines or robots to perform one or more machine functions on metal or plastic workpieces.

Review program specifications or blueprints to determine and set machine operations and sequencing, finished workpiece dimensions, or numerical control sequences.

Listen to machines during operation to detect sounds such as those made by dull cutting tools or excessive vibration and adjust machines to compensate for problems.

Remove and replace dull cutting tools.

### More Tasks for Computer-Controlled Machine Tool Operators, Metal and Plastic

**Top Skills used in this Job**

**Operation Monitoring** - Watching gauges, dials, or other indicators to make sure a machine is working properly.

**Monitoring** - Monitoring/Assessing performance of yourself, other individuals, or organizations to make improvements or take corrective action.

**Critical Thinking** - Using logic and reasoning to identify the strengths and weaknesses of alternative solutions, conclusions or approaches to problems.

**Quality Control Analysis** - Conducting tests and inspections of products, services, or processes to evaluate quality or performance.

**Operation and Control** - Controlling operations of equipment or systems.

**Complex Problem Solving** - Identifying complex problems and reviewing related information to develop and evaluate options and implement solutions.

**Reading Comprehension** - Understanding written sentences and paragraphs in work related documents.

**Judgment and Decision Making** - Considering the relative costs and benefits of potential actions to choose the most appropriate one.

**Active Listening** - Giving full attention to what other people are saying, taking time to understand the points being made, asking questions as appropriate, and not interrupting at inappropriate times.

**Time Management** - Managing one's own time and the time of others.

---

[More Skills for Computer-Controlled Machine Tool Operators, Metal and Plastic](#)

---

**Top Abilities (Attributes of the person that influence performance in this job.)**

**Near Vision** - The ability to see details at close range (within a few feet of the observer).

---

[More Abilities for Computer-Controlled Machine Tool Operators, Metal and Plastic](#)

---

**Top Work Values (Aspects of this job that create satisfaction.)**

**Support** - Occupations that satisfy this work value offer supportive management that stands behind employees.

**Independence** - Occupations that satisfy this work value allow employees to work on their own and make decisions.

---

[More Work Values for Computer-Controlled Machine Tool Operators, Metal and Plastic](#)

---

**Top Interests (The types of activities someone in this job would like.)**

**Realistic** - Realistic occupations frequently involve work activities that include practical, hands-on problems and solutions. They often deal with plants, animals, and real-world materials like wood, tools, and machinery. Many of the occupations require working outside, and do not involve a lot of paperwork or working closely with others.

**Conventional** - Conventional occupations frequently involve following set procedures and routines. These occupations can include working with data and details more than with ideas. Usually there is a clear line of authority to follow.

---

[More Interests for Computer-Controlled Machine Tool Operators, Metal and Plastic](#)

**Related Links**

[LMI for Job Seekers](#)



[Local Area Profile](#)

[Compare Occupations](#)

[O\\*Net - The Occupation Information Network](#)

View a [Career Video](#) for this occupation from America's Career InfoNet (requires [Windows Media Player](#))

[Back](#)

## Computer-Controlled Machine Tool Operators (SOC Code : 51-4011) in Santa Barbara County

Operate computer-controlled machines or robots to perform one or more machine functions on metal or plastic work pieces.

Employers usually expect an employee in this occupation to be able to do the job after Moderate-term on-the-job training (1-12 months) .

Santa Barbara County is part of the Santa Maria-Santa Barbara MSA, which includes Santa Barbara and Santa Maria-Santa Barb counties.

### Occupational Wages

Area	Year	Period	Hourly Mean	Hourly by Percentile		
				25th	Median	75th
California	2014	1st Qtr	\$19.09	\$14.44	\$18.12	\$22.85

### Occupational Projections of Employment (also called "Outlook" or "Demand")

[Top](#)

Area	Estimated Year-Projected Year	Employment		Employment Change		Annual Avg Openings
		Estimated	Projected	Number	Percent	
Santa Barbara County	2012 - 2022	120	160	40	33.3	7

**Industries Employing This Occupation (click on Industry Title to View Employers List) [\[Top\]](#)**

Industry Title	Number of Employers in Santa Barbara County	Employment for Occupation in State of California	Percent of Total
<a href="#">Machine Shops and Threaded Products</a>	48		20.1%
<a href="#">Aerospace Product &amp; Parts Manufacturing</a>	8		16.4%
<a href="#">Semiconductor and Electronic Components</a>	17		11.7%
<a href="#">Metalworking Machinery Manufacturing</a>	1		7.7%
<a href="#">Architectural and Structural Metals</a>	16		4.4%
<a href="#">Other Fabricated Metal Product Mfg</a>	8		4.3%
<a href="#">Electronic Instrument Manufacturing</a>	30		4.2%
<a href="#">Medical Equipment and Supplies Mfg</a>	47		3.5%
<a href="#">Other General Purpose Machinery Mfg</a>	14		3.0%
<a href="#">Communications Equipment Manufacturing</a>	6		1.5%
<a href="#">Other Miscellaneous Manufacturing</a>	79		1.1%

**About This Occupation (from O\*NET - The Occupation Information Network)****Top Tasks (Specific duties and responsibilities of this job.)**

Measure dimensions of finished workpieces to ensure conformance to specifications, using precision measuring instruments, templates, and fixtures.

Mount, install, align, and secure tools, attachments, fixtures, and workpieces on machines, using hand tools and precision measuring instruments.

Stop machines to remove finished workpieces or to change tooling, setup, or workpiece placement, according to required machining sequences.

Transfer commands from servers to computer numerical control (CNC) modules, using computer network links.

Check to ensure that workpieces are properly lubricated and cooled during machine operation.

Insert control instructions into machine control units to start operation.

Set up and operate computer-controlled machines or robots to perform one or more machine functions on metal or plastic workpieces.

Review program specifications or blueprints to determine and set machine operations and sequencing, finished workpiece dimensions, or numerical control sequences.

Listen to machines during operation to detect sounds such as those made by dull cutting tools or excessive vibration and adjust machines to compensate for problems.

Remove and replace dull cutting tools.

## More Tasks for Computer-Controlled Machine Tool Operators, Metal and Plastic

---

### Top Skills used in this Job

**Operation Monitoring** - Watching gauges, dials, or other indicators to make sure a machine is working properly.

**Monitoring** - Monitoring/Assessing performance of yourself, other individuals, or organizations to make improvements or take corrective action.

**Critical Thinking** - Using logic and reasoning to identify the strengths and weaknesses of alternative solutions, conclusions or approaches to problems.

**Quality Control Analysis** - Conducting tests and inspections of products, services, or processes to evaluate quality or performance.

**Operation and Control** - Controlling operations of equipment or systems.

**Complex Problem Solving** - Identifying complex problems and reviewing related information to develop and evaluate options and implement solutions.

**Reading Comprehension** - Understanding written sentences and paragraphs in work related documents.

**Judgment and Decision Making** - Considering the relative costs and benefits of potential actions to choose the most appropriate one.

**Active Listening** - Giving full attention to what other people are saying, taking time to understand the points being made, asking questions as appropriate, and not interrupting at inappropriate times.

**Time Management** - Managing one`s own time and the time of others.

## More Skills for Computer-Controlled Machine Tool Operators, Metal and Plastic

---

### Top Abilities (Attributes of the person that influence performance in this job.)

**Near Vision** - The ability to see details at close range (within a few feet of the observer).

## More Abilities for Computer-Controlled Machine Tool Operators, Metal and Plastic

---

### Top Work Values (Aspects of this job that create satisfaction.)

**Support** - Occupations that satisfy this work value offer supportive management that stands behind employees.

**Independence** - Occupations that satisfy this work value allow employees to work on their own and make decisions.

## More Work Values for Computer-Controlled Machine Tool Operators, Metal and Plastic

---

### Top Interests (The types of activities someone in this job would like.)

**Realistic** - Realistic occupations frequently involve work activities that include practical, hands-on problems and solutions. They often deal with plants, animals, and real-world materials like wood, tools, and machinery. Many of the occupations require working outside, and do not involve a lot of paperwork or working closely with others.

**Conventional** - Conventional occupations frequently involve following set procedures and routines. These occupations can include working with data and details more than with ideas. Usually there is a clear line of authority to follow.



**Computer-Controlled Machine Tool Operators**  
 (SOC Code : 51-4011)  
 in San Luis Obispo County

Operate computer-controlled machines or robots to perform one or more machine functions on metal or plastic work pieces.

Employers usually expect an employee in this occupation to be able to do the job after Moderate-term on-the-job training (1-12 months) .

San Luis Obispo County is the same as San Luis Obispo-Paso Robles-Arroyo Grande MSA.

**Occupational Wages**

Area	Year	Period	Hourly Mean	Hourly by Percentile		
				25th	Median	75th
San Luis Obispo-Paso Robles-Arroyo Grande MSA	2014	1st Qtr	\$15.98	\$11.03	\$14.96	\$18.37

**Industries Employing This Occupation (click on Industry Title to View Employers List)**

Industry Title	Number of Employers in San Luis Obispo County		Percent of Total
	Employment for Occupation in State of California	Employment for Occupation in State of California	Employment for Occupation in State of California

<u>Machine Shops and Threaded Products</u>	56	20.1%
<u>Aerospace Product &amp; Parts Manufacturing</u>	2	16.4%
<u>Semiconductor and Electronic Components</u>	5	11.7%
<u>Metalworking Machinery Manufacturing</u>	6	7.7%
<u>Architectural and Structural Metals</u>	23	4.4%
<u>Other Fabricated Metal Product Mfg</u>	9	4.3%
<u>Electronic Instrument Manufacturing</u>	9	4.2%
<u>Medical Equipment and Supplies Mfg</u>	28	3.5%
<u>Other General Purpose Machinery Mfg</u>	12	3.0%
<u>Communications Equipment Manufacturing</u>	4	1.5%
<u>Other Miscellaneous Manufacturing</u>	83	1.1%

### About This Occupation (from O\*NET - The Occupation Information Network)

#### Top Tasks (Specific duties and responsibilities of this job.)

Measure dimensions of finished workpieces to ensure conformance to specifications, using precision measuring instruments, templates, and fixtures.

Mount, install, align, and secure tools, attachments, fixtures, and workpieces on machines, using hand tools and precision measuring instruments.

Stop machines to remove finished workpieces or to change tooling, setup, or workpiece placement, according to required machining sequences.

Transfer commands from servers to computer numerical control (CNC) modules, using computer network links.

Check to ensure that workpieces are properly lubricated and cooled during machine operation.

Insert control instructions into machine control units to start operation.

Set up and operate computer-controlled machines or robots to perform one or more machine functions on metal or plastic workpieces.

Review program specifications or blueprints to determine and set machine operations and sequencing, finished workpiece dimensions, or numerical control sequences.

Listen to machines during operation to detect sounds such as those made by dull cutting tools or excessive vibration and adjust machines to compensate for problems.

Remove and replace dull cutting tools.

#### More Tasks for Computer-Controlled Machine Tool Operators, Metal and Plastic

**Operation Monitoring** - Watching gauges, dials, or other indicators to make sure a machine is working properly.

**Monitoring** - Monitoring/Assessing performance of yourself, other individuals, or organizations to make improvements or take corrective action.

**Critical Thinking** - Using logic and reasoning to identify the strengths and weaknesses of alternative solutions, conclusions or approaches to problems.

**Quality Control Analysis** - Conducting tests and inspections of products, services, or processes to evaluate quality or performance.

**Operation and Control** - Controlling operations of equipment or systems.

**Complex Problem Solving** - Identifying complex problems and reviewing related information to develop and evaluate options and implement solutions.

**Reading Comprehension** - Understanding written sentences and paragraphs in work related documents.

**Judgment and Decision Making** - Considering the relative costs and benefits of potential actions to choose the most appropriate one.

**Active Listening** - Giving full attention to what other people are saying, taking time to understand the points being made, asking questions as appropriate, and not interrupting at inappropriate times.

**Time Management** - Managing one`s own time and the time of others.

#### More Skills for Computer-Controlled Machine Tool Operators, Metal and Plastic

---

Top Abilities (Attributes of the person that influence performance in this job.)

**Near Vision** - The ability to see details at close range (within a few feet of the observer).

#### More Abilities for Computer-Controlled Machine Tool Operators, Metal and Plastic

---

Top Work Values (Aspects of this job that create satisfaction.)

**Support** - Occupations that satisfy this work value offer supportive management that stands behind employees.

**Independence** - Occupations that satisfy this work value allow employees to work on their own and make decisions.

#### More Work Values for Computer-Controlled Machine Tool Operators, Metal and Plastic

---

Top Interests (The types of activities someone in this job would like.)

**Realistic** - Realistic occupations frequently involve work activities that include practical, hands-on problems and solutions. They often deal with plants, animals, and real-world materials like wood, tools, and machinery. Many of the occupations require working outside, and do not involve a lot of paperwork or working closely with others.

**Conventional** - Conventional occupations frequently involve following set procedures and routines. These occupations can include working with data and details more than with ideas. Usually there is a clear line of authority to follow.

# Manufacturing Education Summit

Hosted by Allan Hancock  
College

May 20, 2014

Dr. Jose Macedo  
Keynote Speaker

Industrial and Manufacturing Engineering  
California Polytechnic State University  
San Luis Obispo, CA



# Presentation Outline

1. Technological change
2. State of manufacturing in the USA
3. Examples of manufacturing in CA (West)
4. Advances in manufacturing
5. Skills & knowledge for manufacturing
6. Some recommendations

# 1. Constant, Fast Changes in Technology

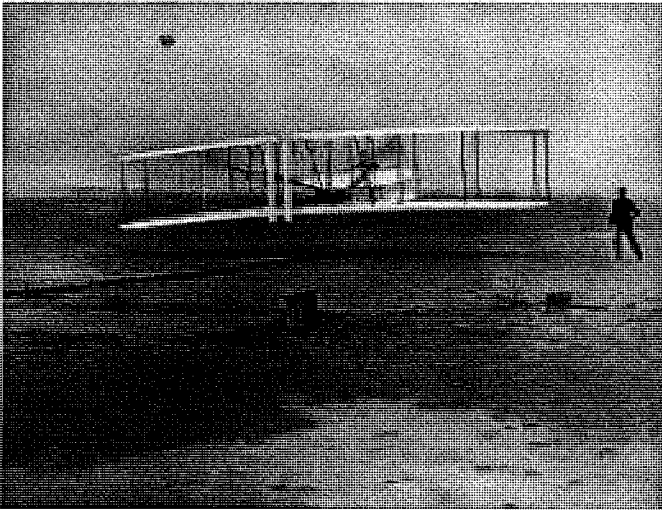

First Flight – Wright Brothers - 1903



First Moon Walk – Armstrong- July 1969

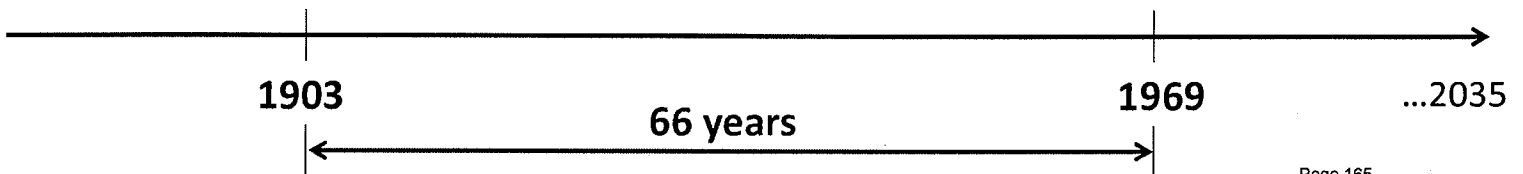

# Manufacturing Technology Change

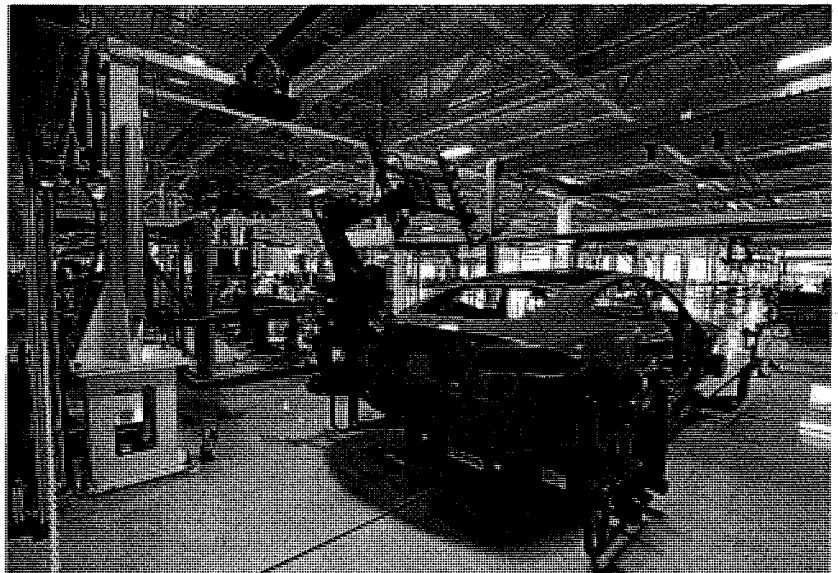
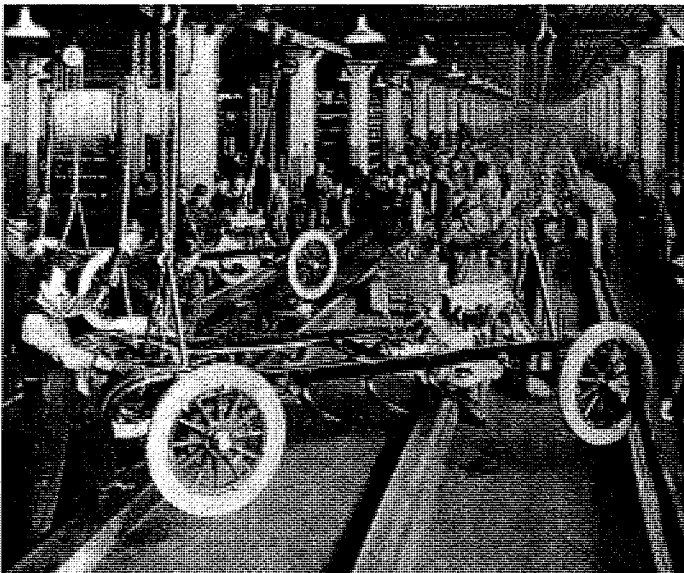

~100 Years

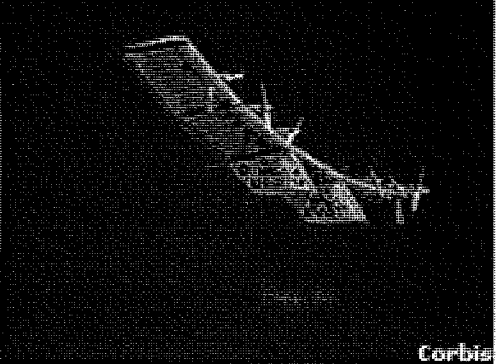
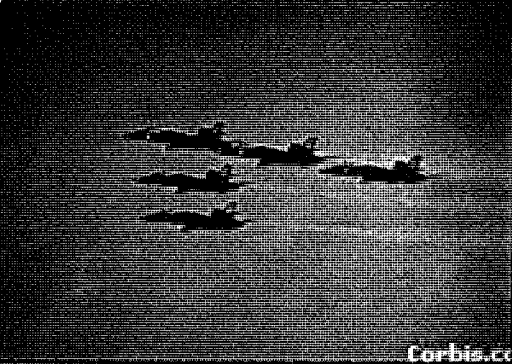
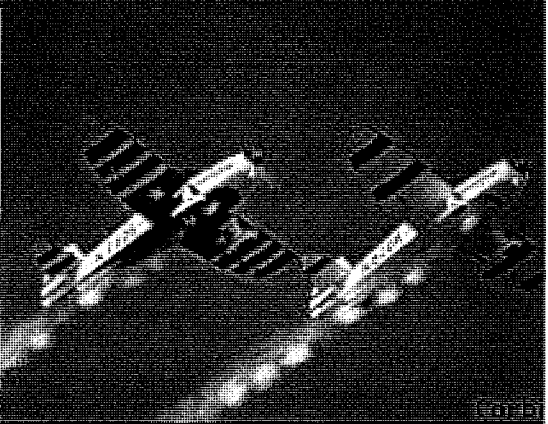
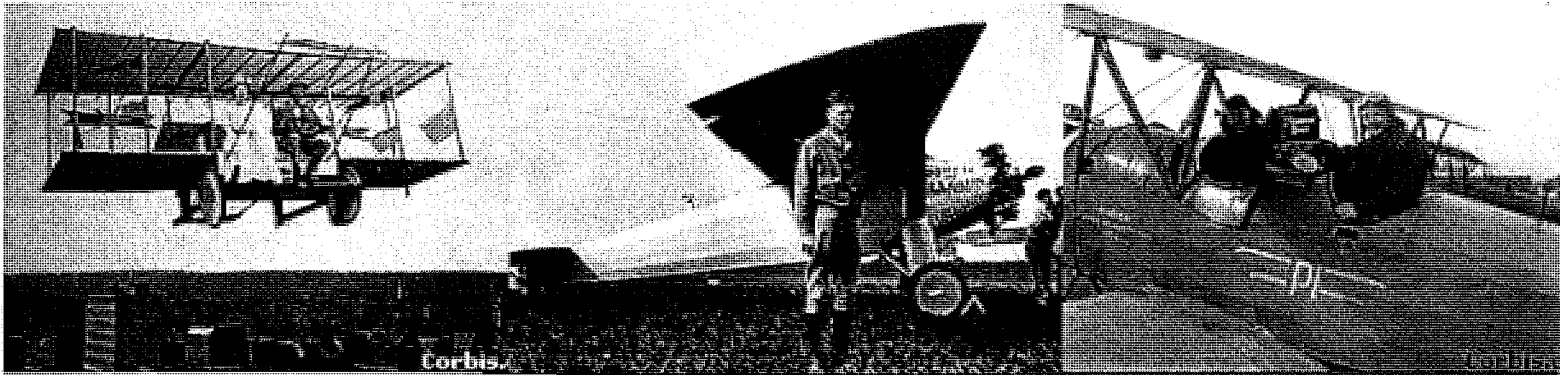

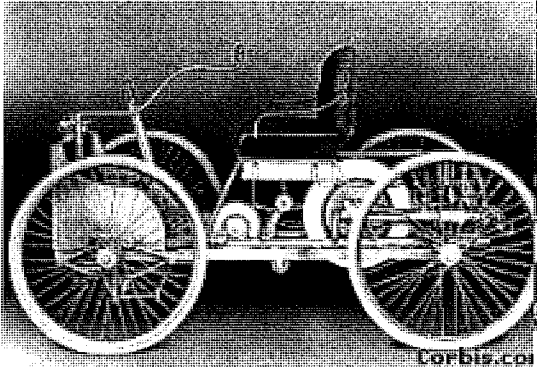

Corbis.com

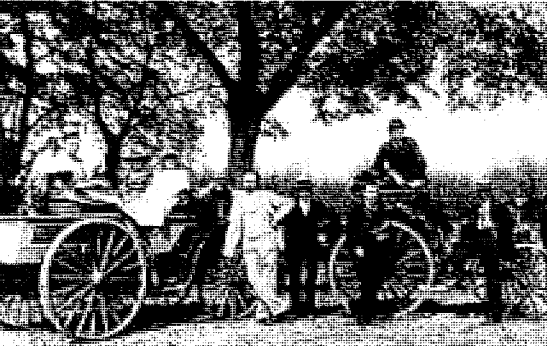

Corbis.com

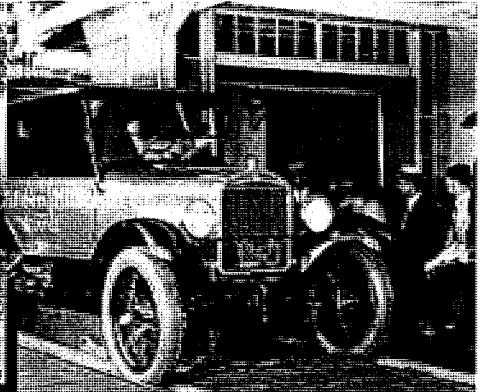

Corbis.com

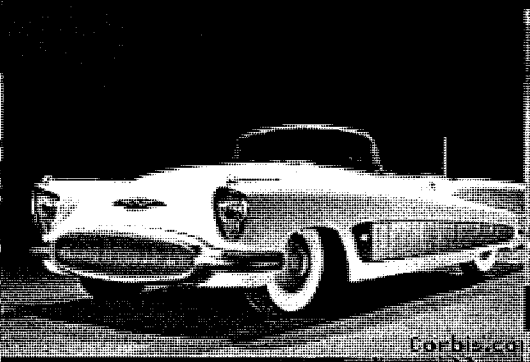

Corbis.com



Corbis.com

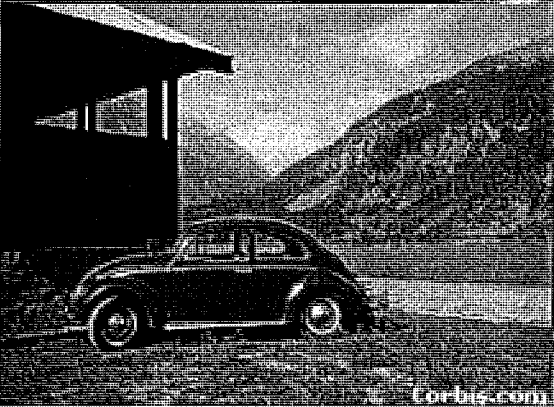

Corbis.com



Corbis.com

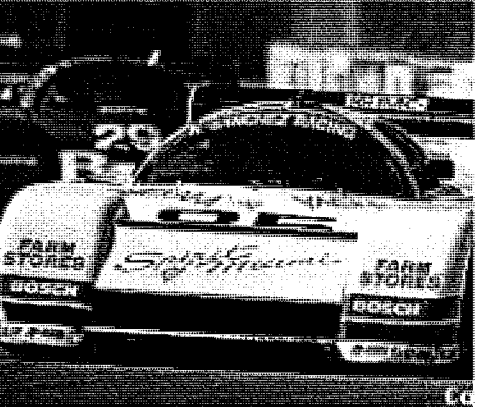

Corbis.com

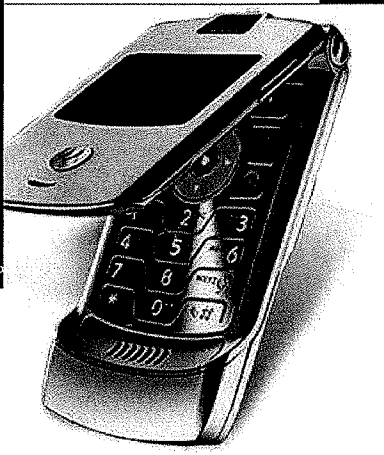
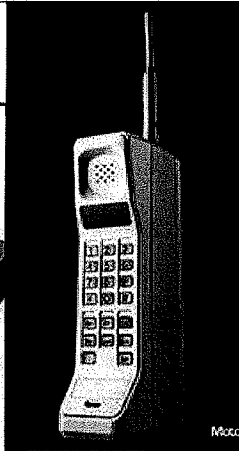
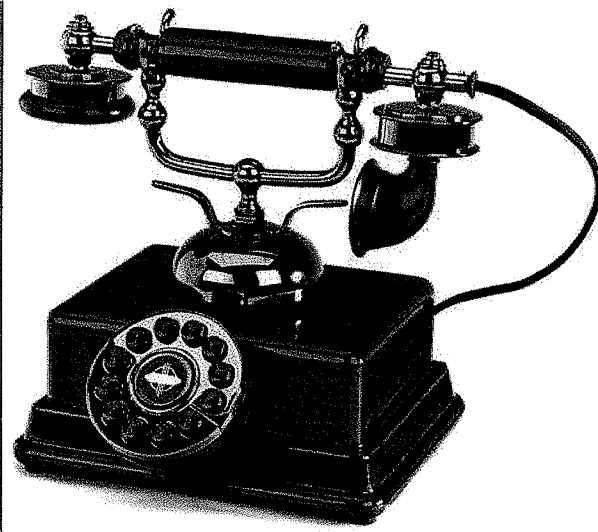

What will these products look 100 years from now?

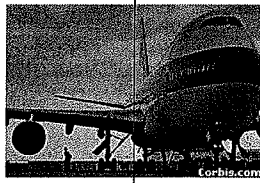
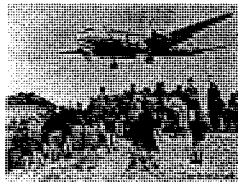
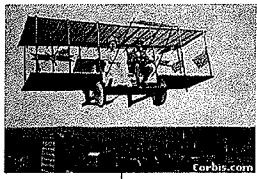

? ? ?

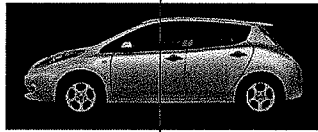
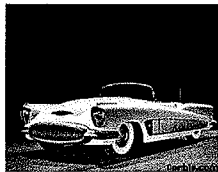
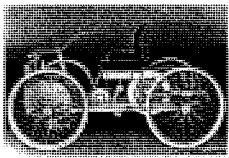

? ? ?

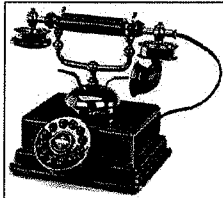
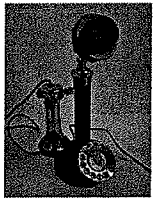

? ? ?

1900

2014  
Today

2114  
100-years in the future

What will manufacturing look 100 years from now?

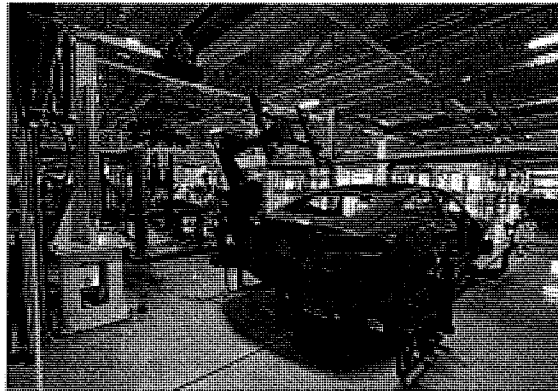
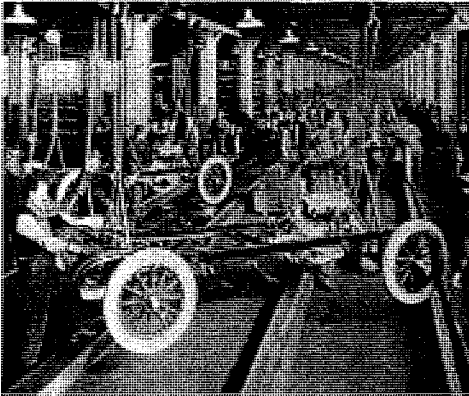

? ? ?

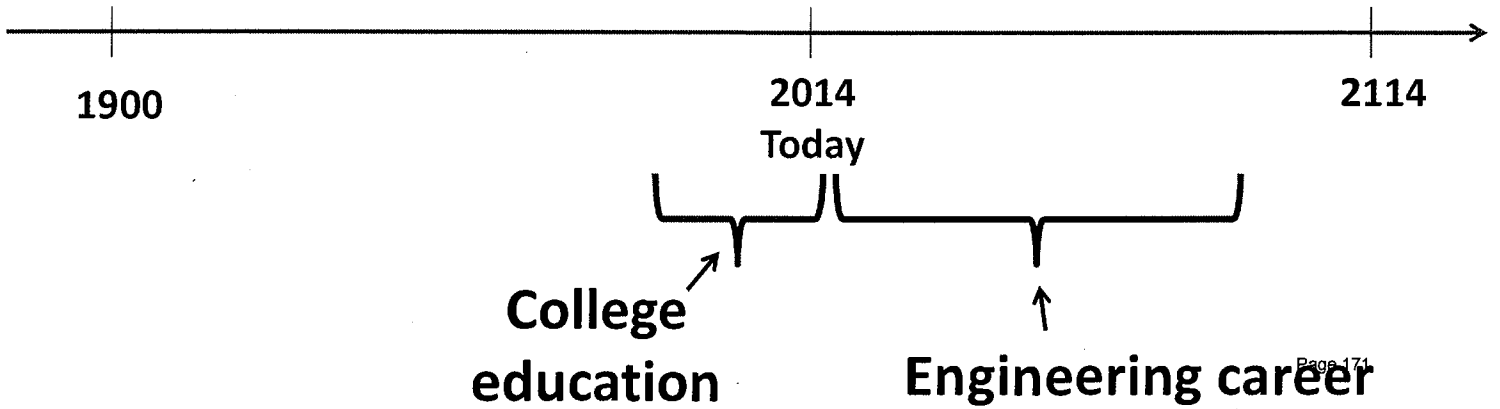



How can we teach how to design the products and processes of the future, when nobody knows what they will be?

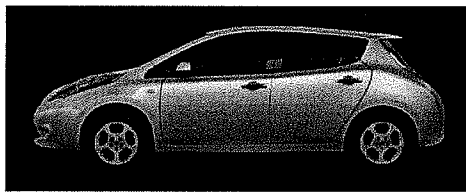
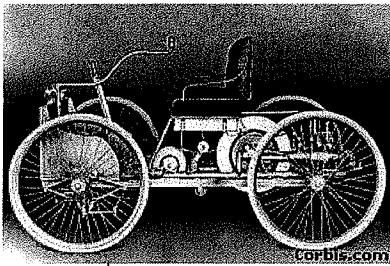

? ? ?

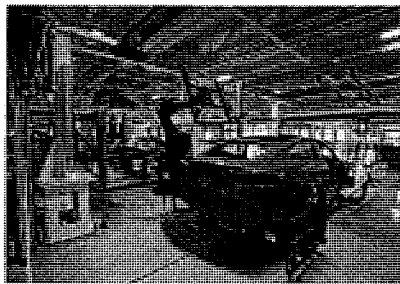
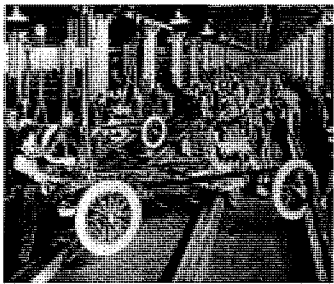

? ? ?

1900

2014  
Today

2114  
Page 172

# Average Career

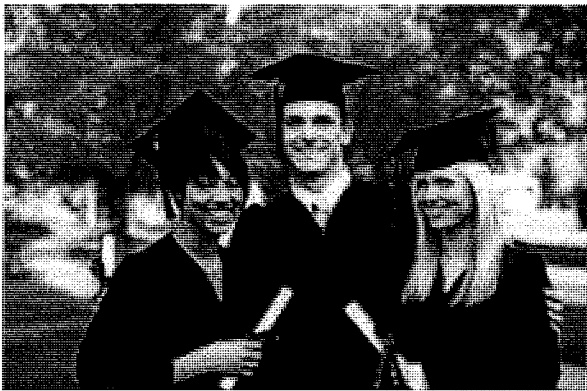

Graduate at age 22



Retire at age 65

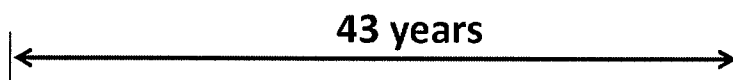

## Things to consider

- Technical competency requires to learn – constantly – throughout career, “life-long learning”.
- What should we teach in college?

## 2. Manufacturing in the U.S.

Time Magazine  
April 22, 2013



**Figure I. Value Added in Manufacturing**  
Billions of U.S. Dollars, 2010

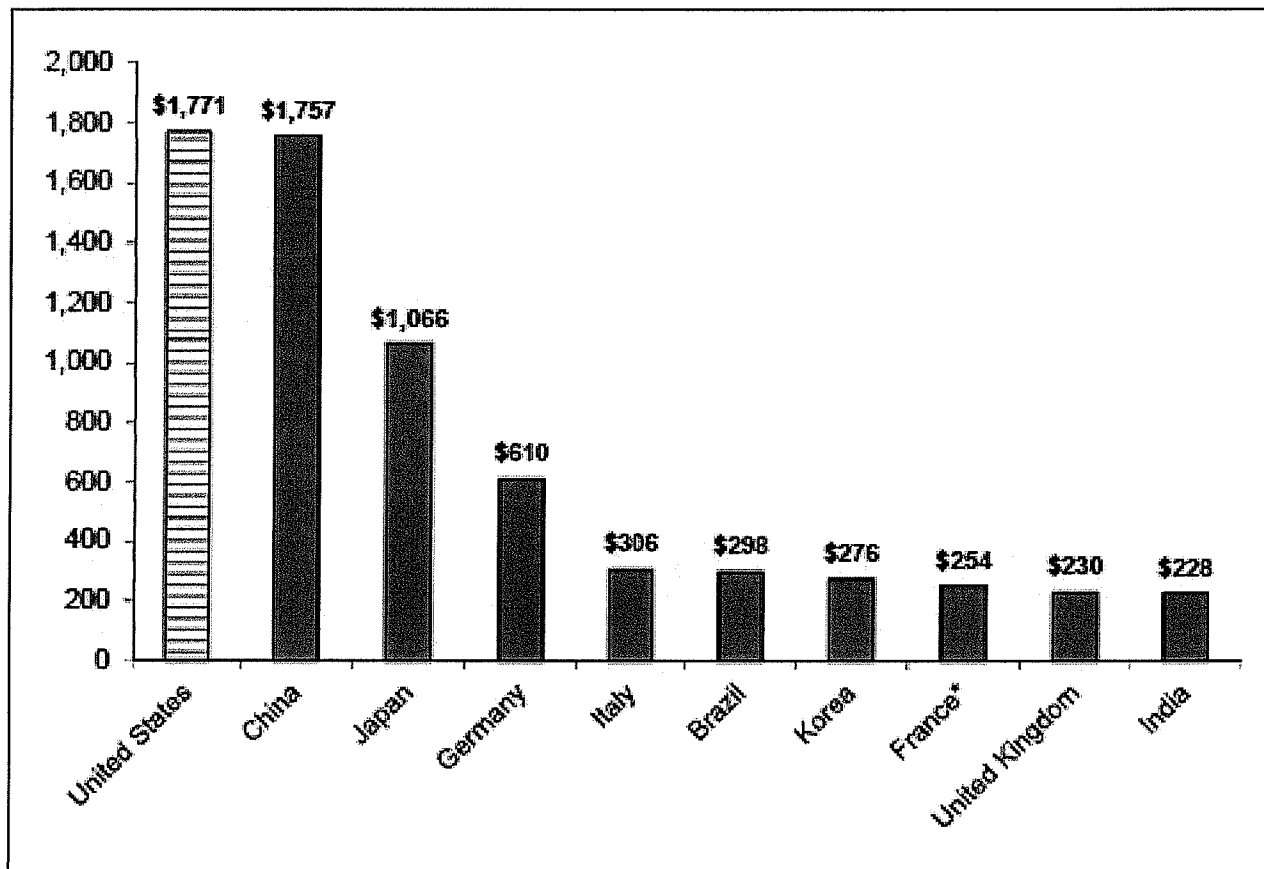

Source: World Bank, <http://data.worldbank.org/indicator/NV.IND.MANF.CD>.

Note: \* Data for France are for 2009.

# Manufacturing in the U.S. vs China

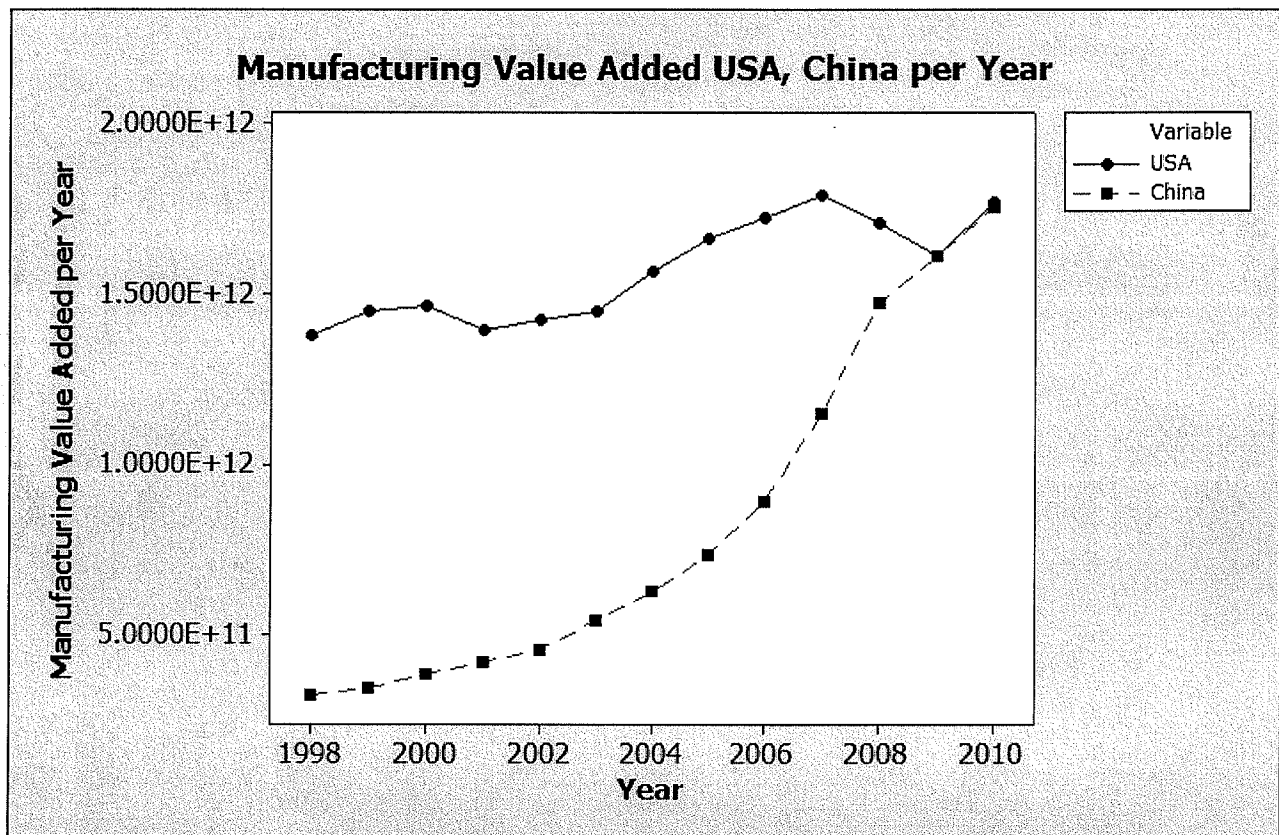

World Bank Report 2012 <http://data.worldbank.org/indicator/NV.IND.MANF.CD>. Manufacturing refers to industries belonging to ISIC divisions 15-37. Value added is the net output of a sector after adding up all outputs and subtracting intermediate inputs. It is calculated without making deductions for depreciation of fabricated assets or depletion and degradation of natural resources. The origin of value added is determined by the International Standard Industrial Classification (ISIC), revision 3. Data are in current U.S. dollars.

# Manufacturing Value Added (current US\$)

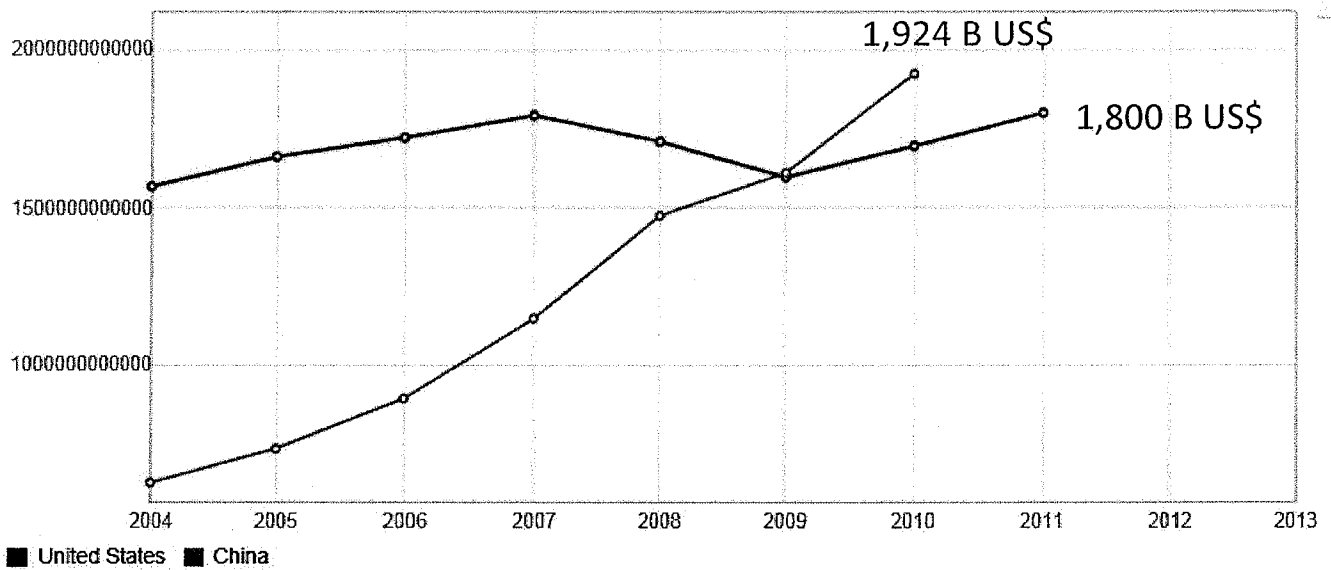

Source: World Bank <http://data.worldbank.org/indicator/NV.IND.MANF.CD/>

# The U.S. Manufacturing Sector Is the Tenth-Largest Economy (Updated May 2013)

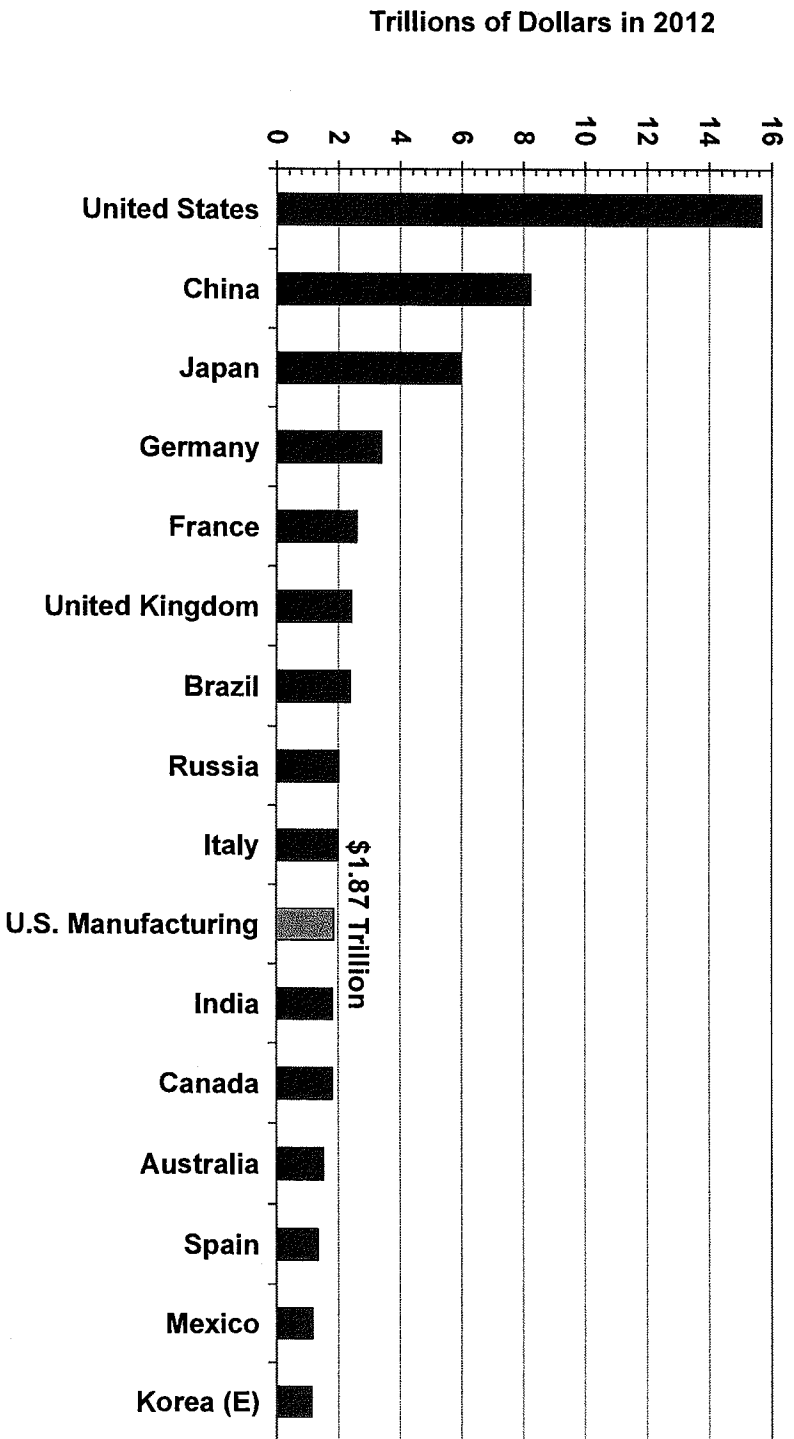

From The Manufacturing Institute  
Source(s): International Monetary Fund and U.S. Bureau of Economic Analysis and MAPI



# U.S. Manufacturing Employment

By Quarter, in Millions of Jobs

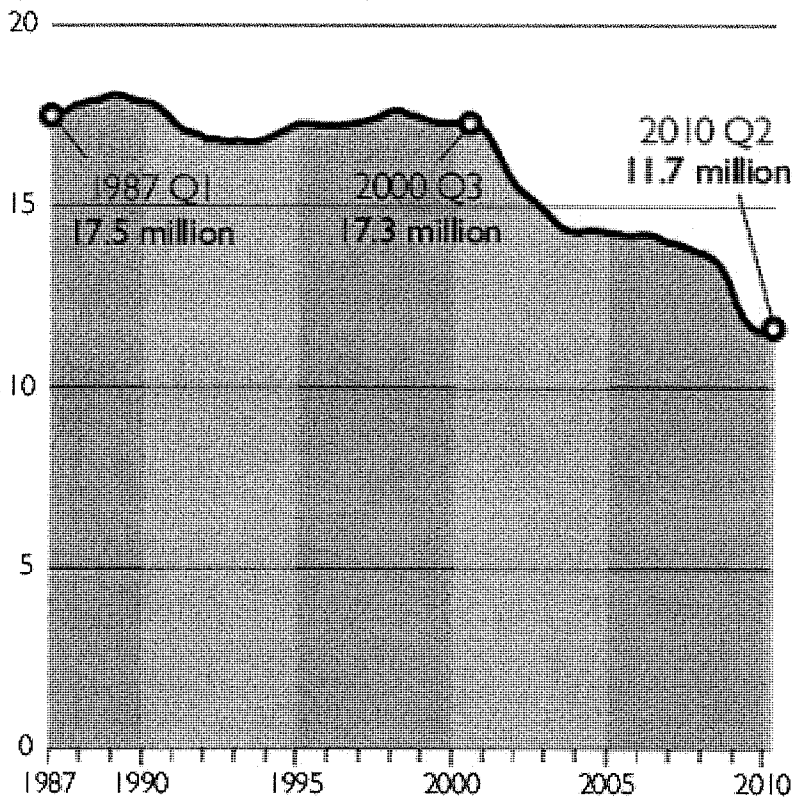

Source: Heritage Foundation calculations using data from the U.S. Department of Labor, Bureau of Labor Statistics, Establishment Survey, 1987-2010, in Data Link Express, Haver Analytics

Chart I • B 2476 heritage.org

# Manufacturing Jobs by Education Level

Millions of Manufacturing Workers

The manufacturing industry in the U.S. has added more employees with college degrees. The number of workers without degrees has declined.

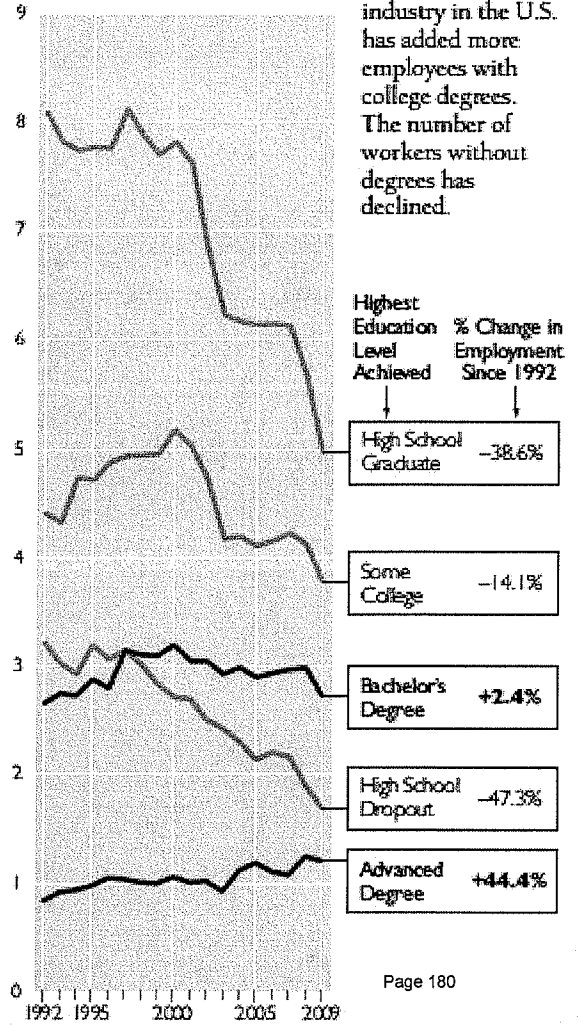

## The Manufacturing Workforce Has Become More Educated (Updated May 2013)

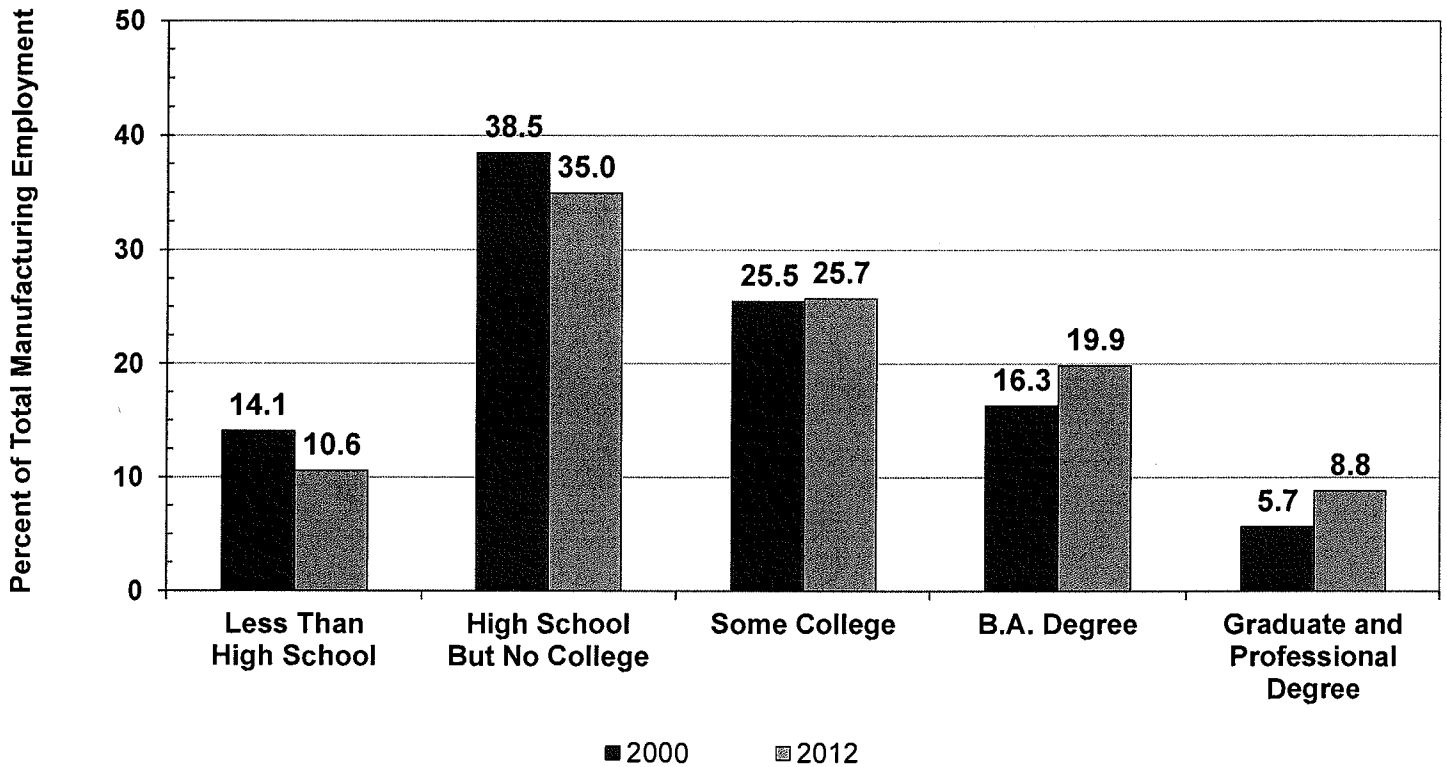

Source(s): U.S. Bureau of Labor Statistics, Current Population Survey and MAPI

**Number of Jobs in Manufacturing**  
*(Updated November 2013)*

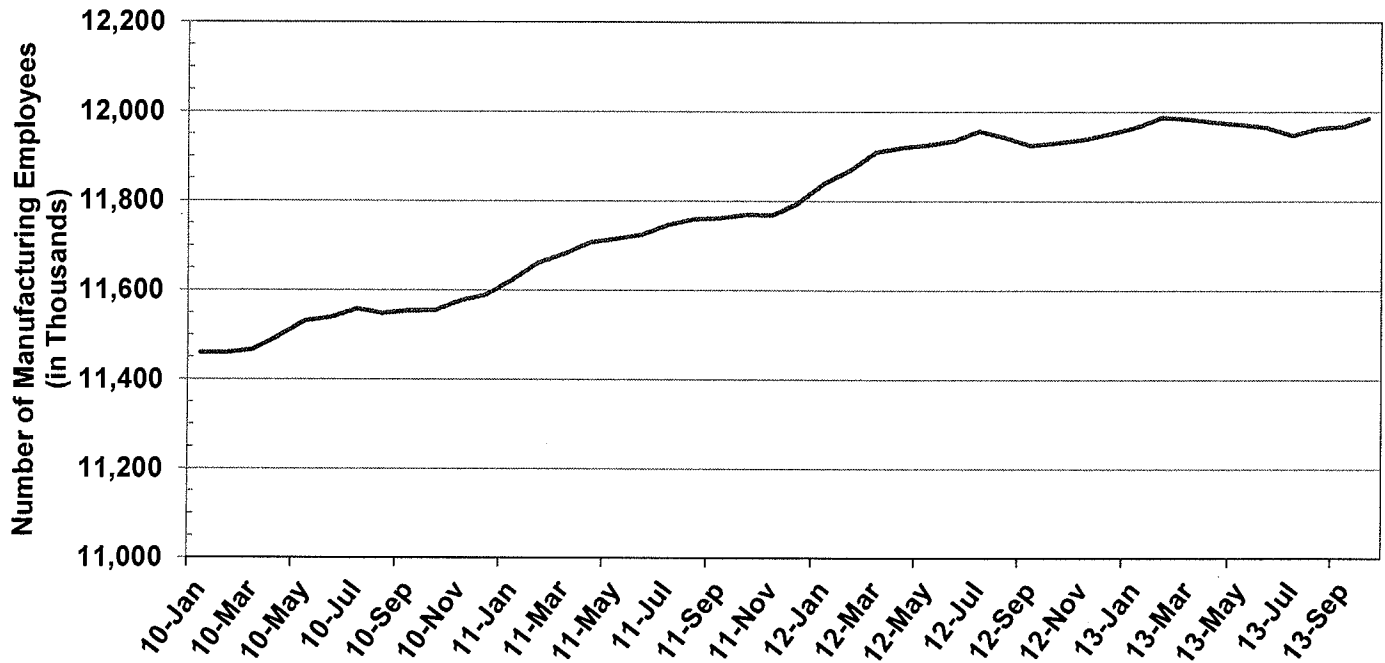

Source(s): U.S. Bureau of Labor Statistics

## The United States Lags Significantly in Graduating Engineers (Updated January 2013)

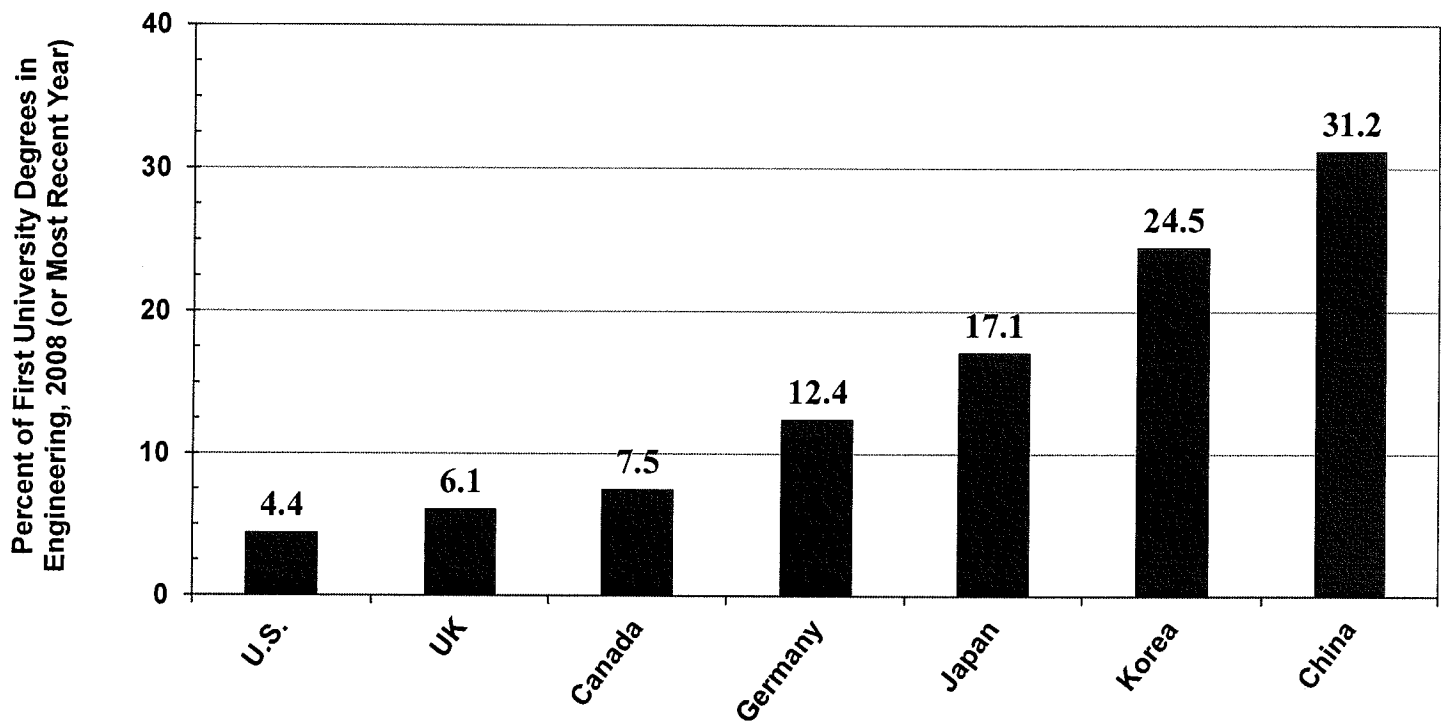

Source(s): National Science Foundation, Science and Engineering Indicators and MAPI

### **3. Examples of Successful Manufacturing in the US West Coast (excluding defense)**

# HAAS Automation

Oxnard, CA

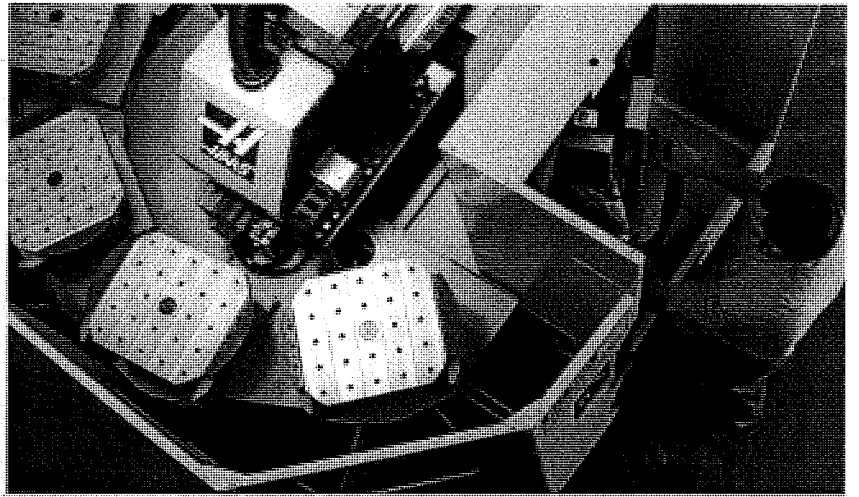
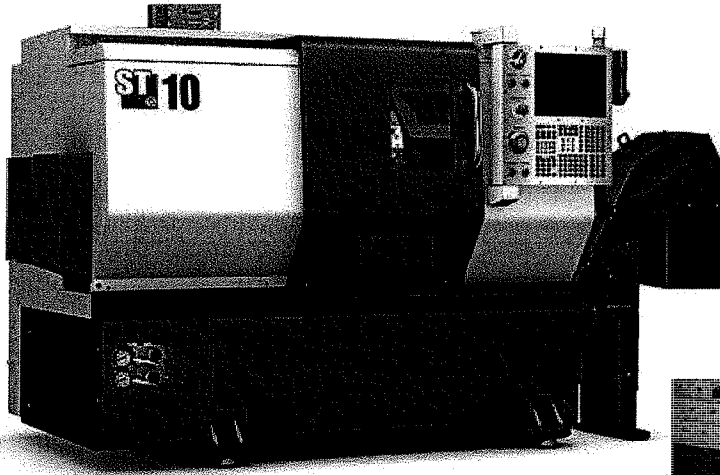
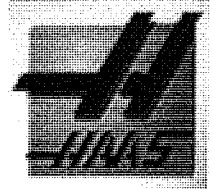

# Solar Turbines

San Diego, CA

## Solar Turbines

*A Caterpillar Company*

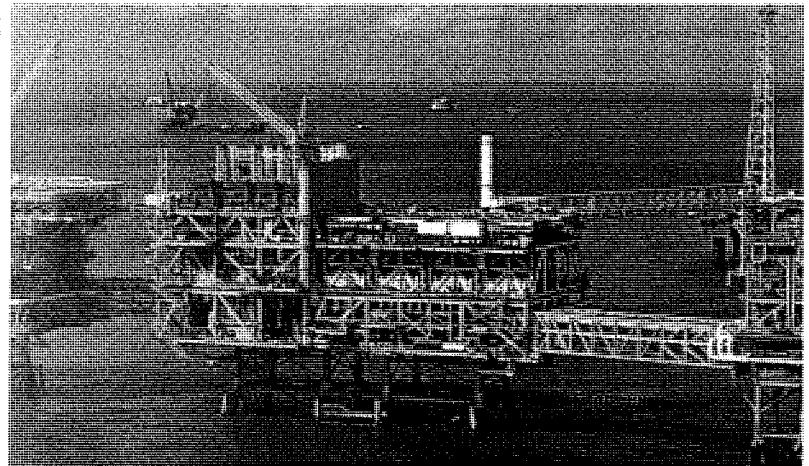
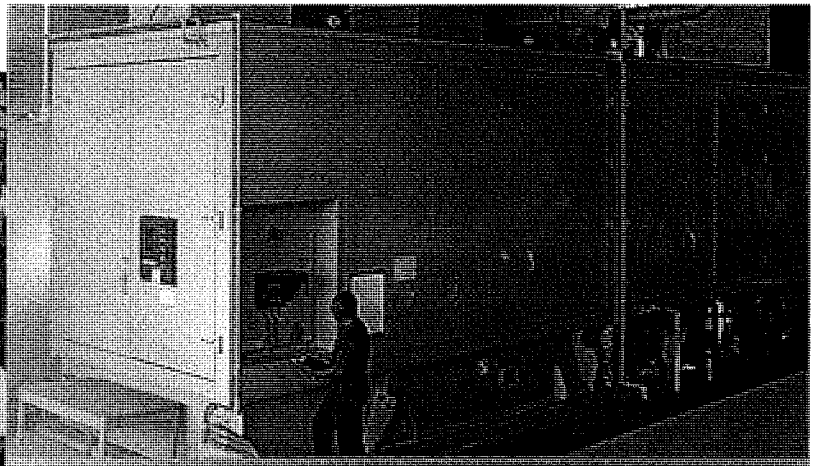
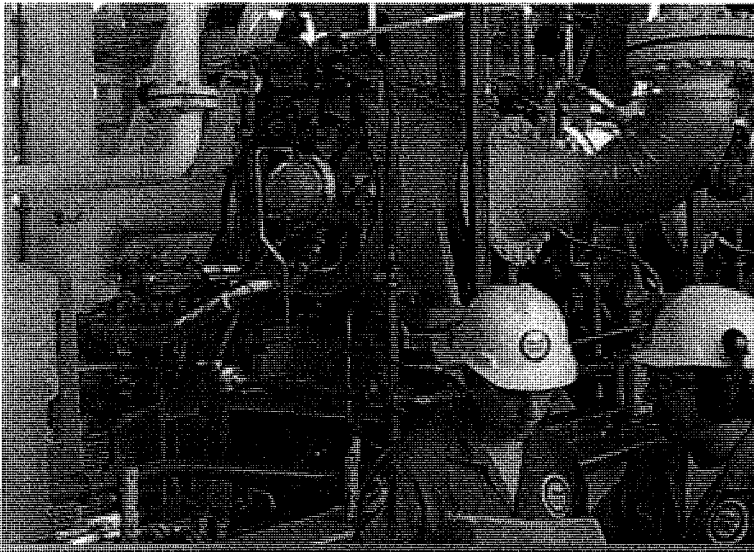

# Tesla Motors

Fremont, CA

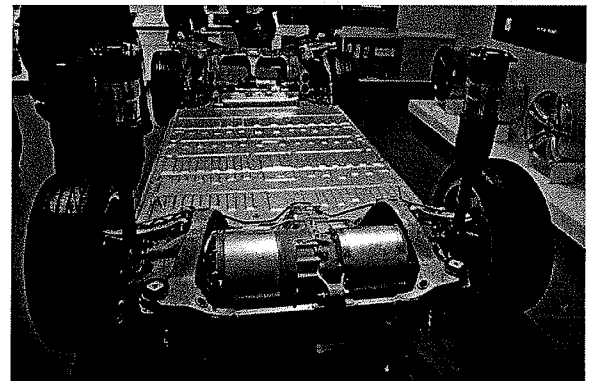
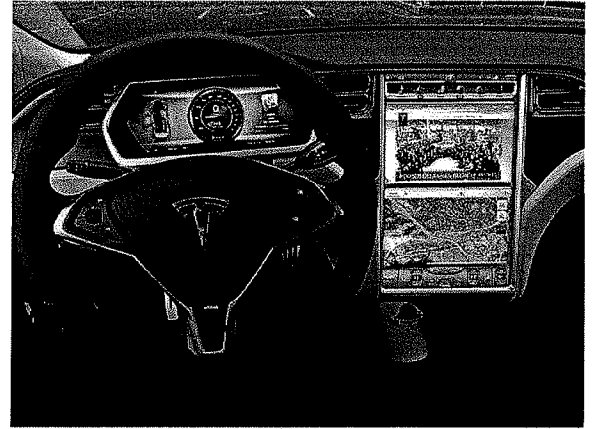
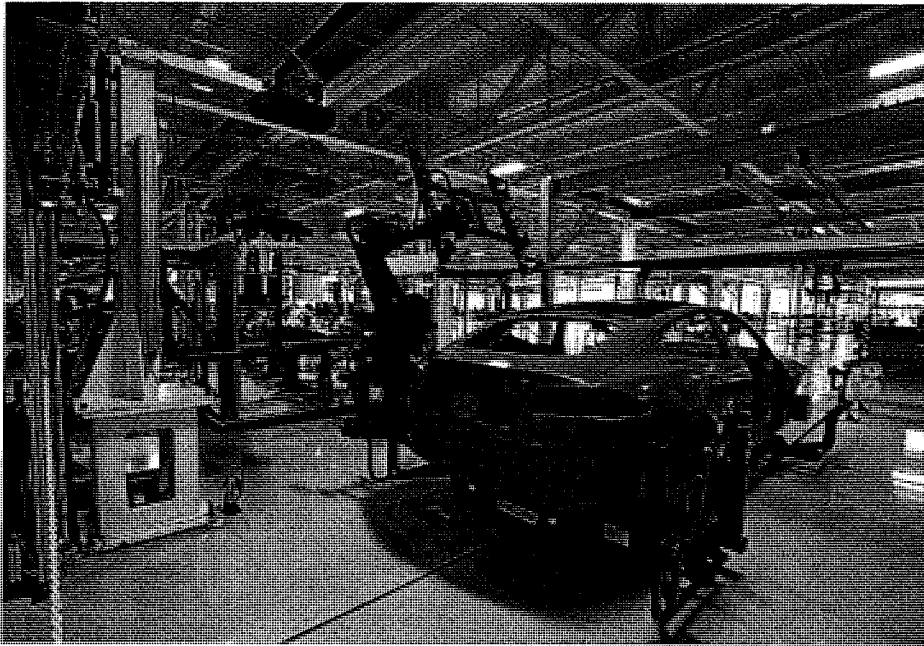



# Robinson Helicopter

Torrance, CA

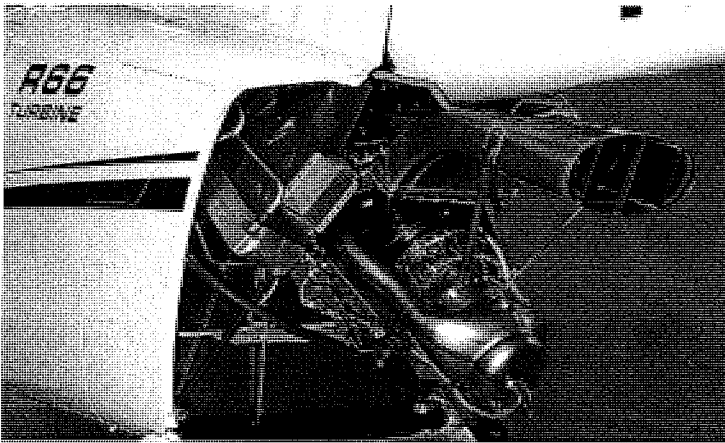

# Next Intent

San Luis Obispo, CA

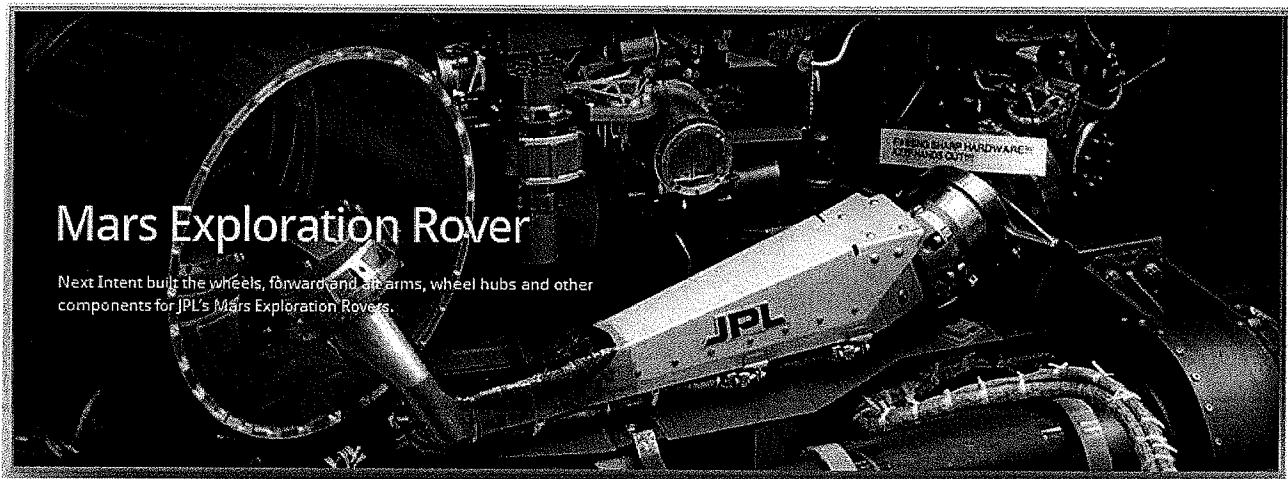

## Mars Exploration Rover

Next Intent built the wheels, forward and air arms, wheel hubs and other components for JPL's Mars Exploration Rovers.

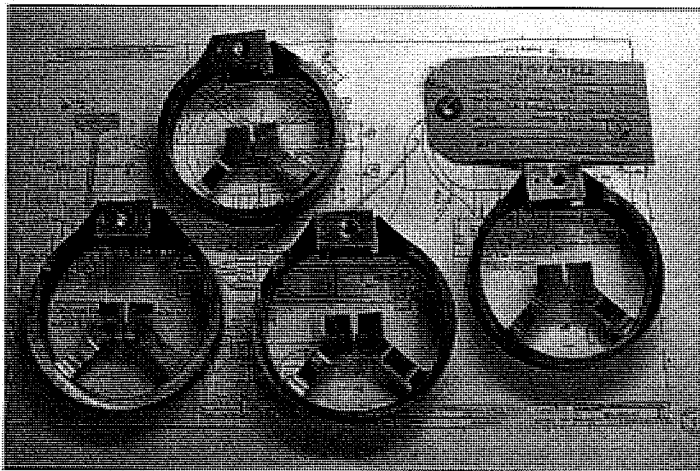

# Melfred Borzall

Santa Maria, CA

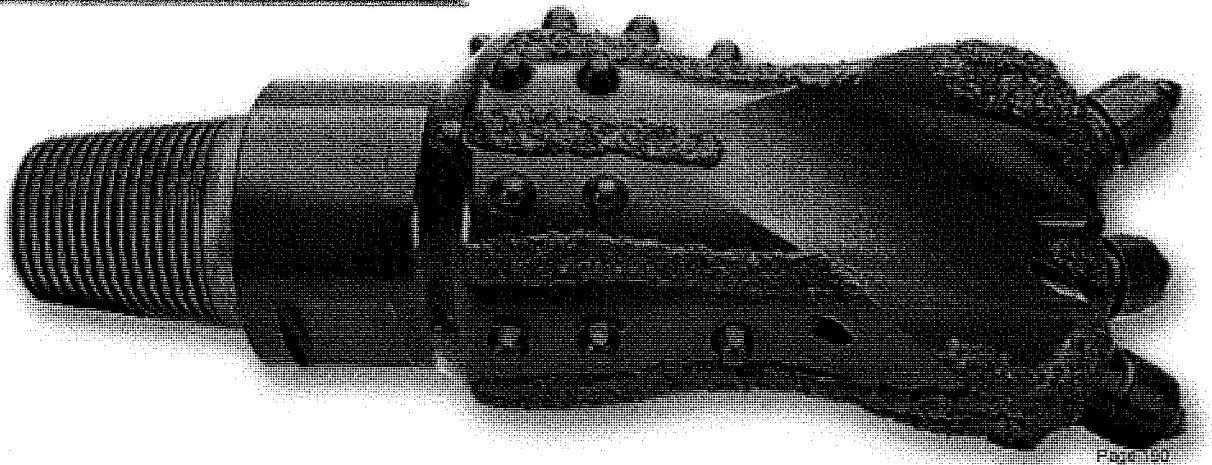

Page 50

# Intuitive Surgical

Sunnyvale, CA

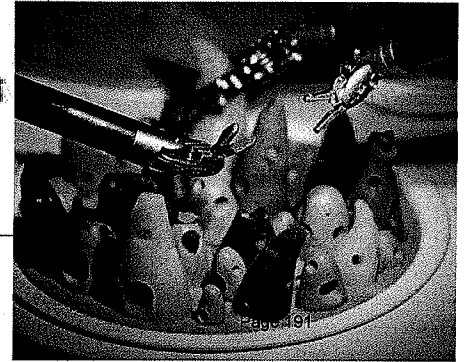
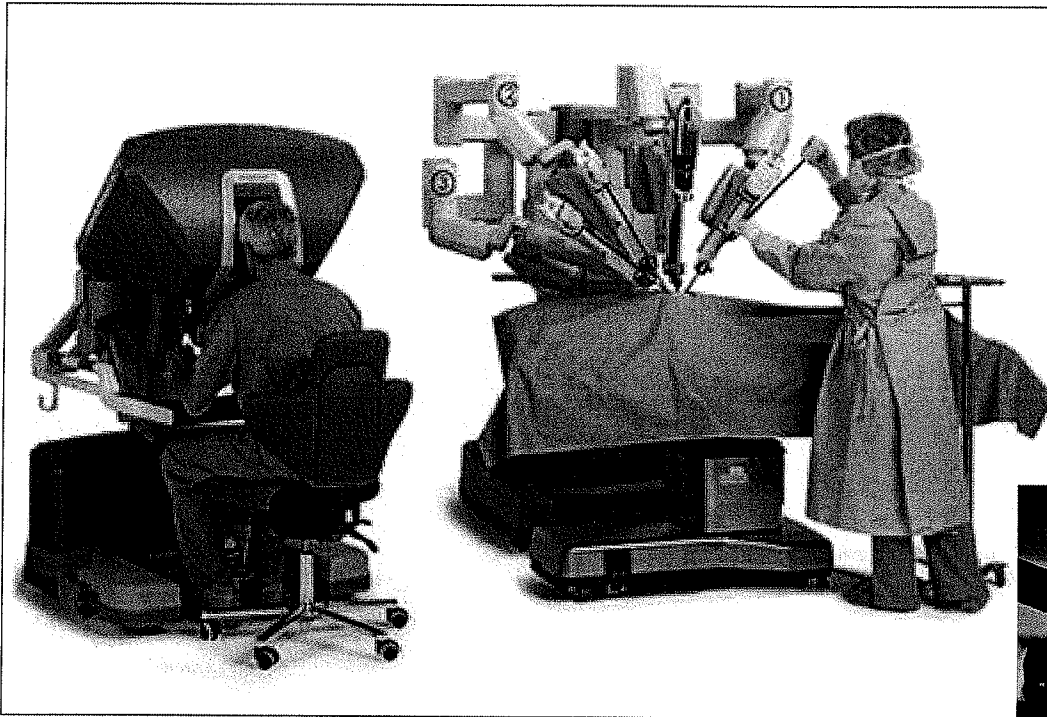

# Schilling Robotics

Davis, CA

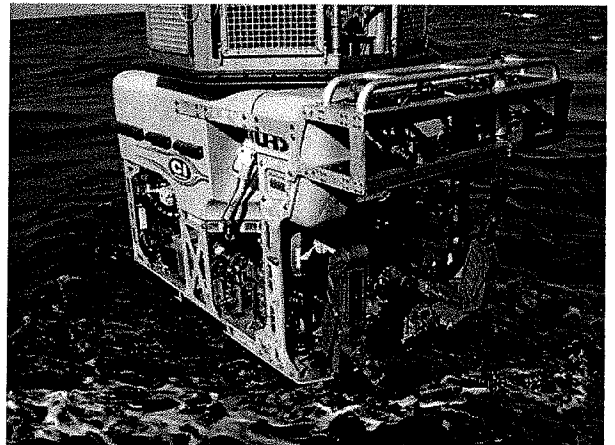
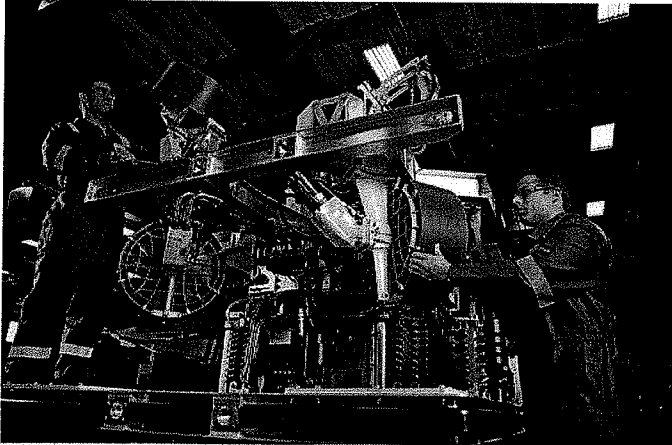
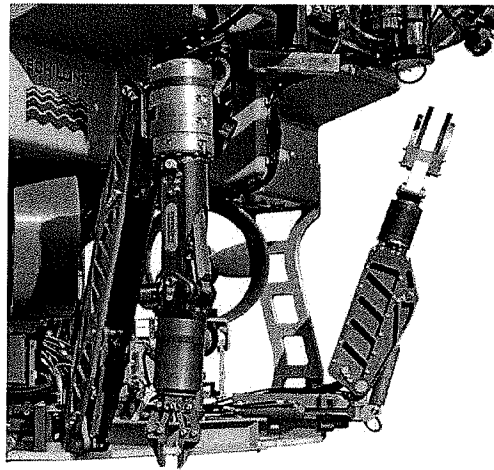

**Alcon**  
Irvine, CA

**Alcon<sup>®</sup>**

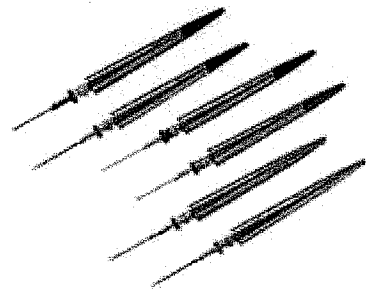
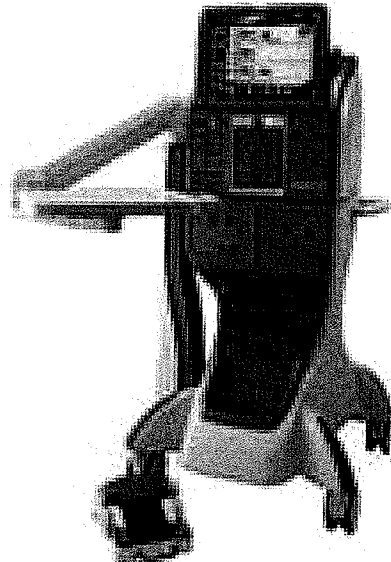
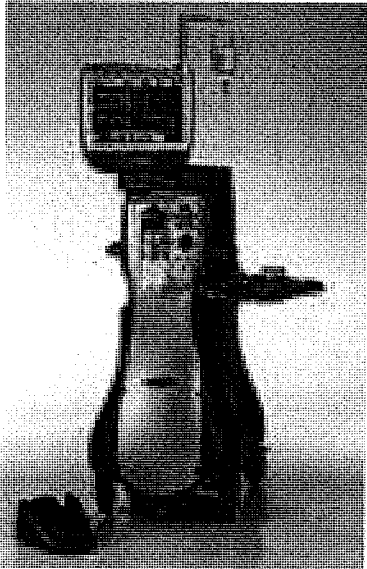

# 4. Advances in Manufacturing

# 3D Scanning Integrated to CAD

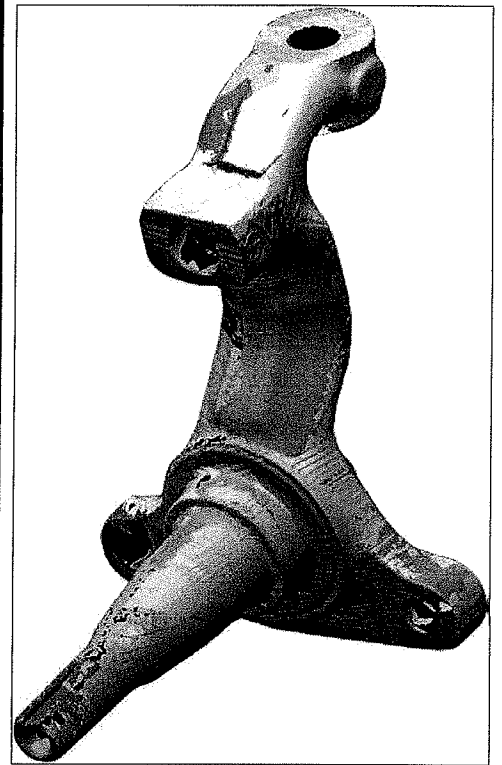
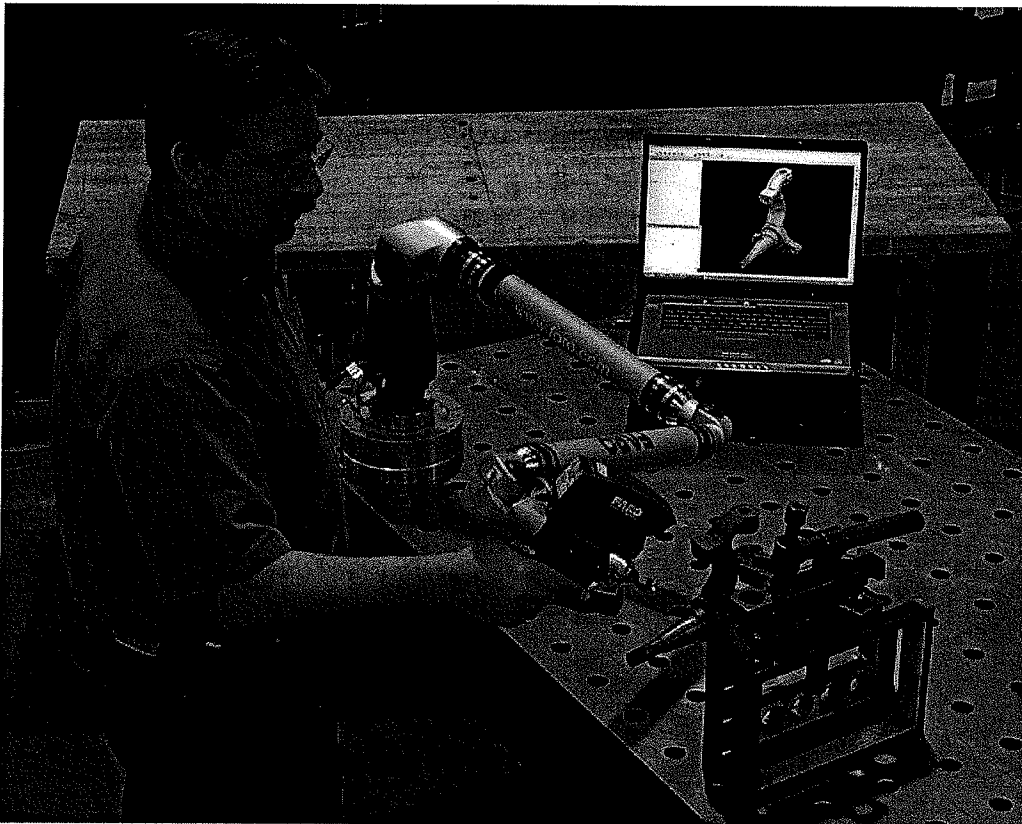



# 3D Printing

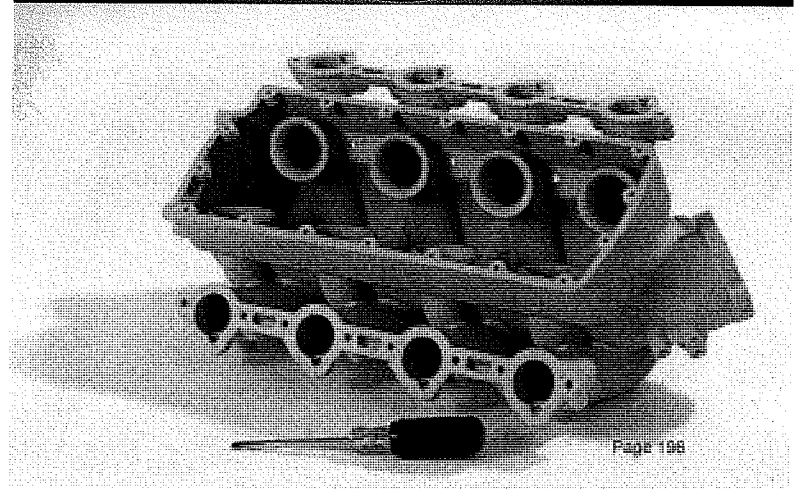
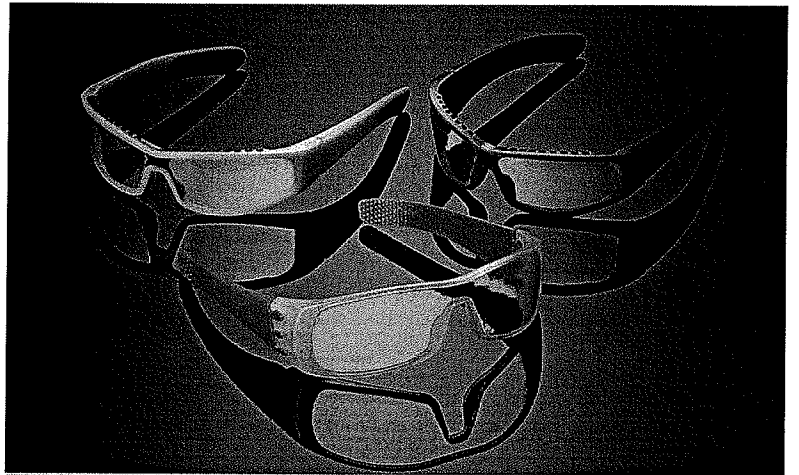
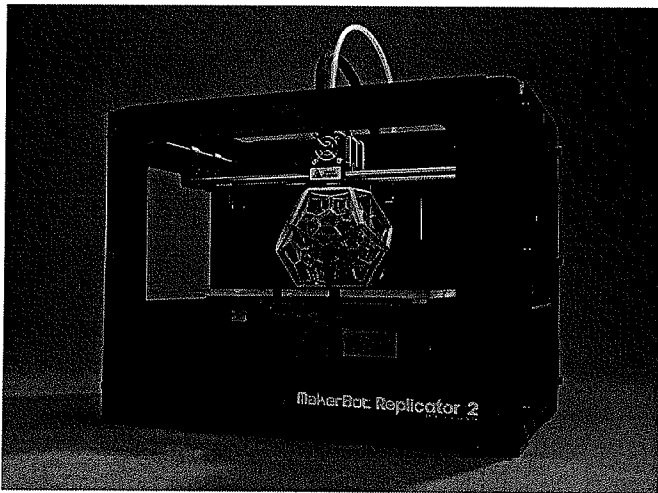

# 3D Printing in Metals



# 3D Printing in Metals



# 3D Printing in Metals

